

Operating instructions

Peristaltic metering pump

DULCO flex Control, DFXa

EN



Target group: trained users

**Please carefully read these operating instructions before use. · Do not discard.
The operator shall be liable for any damage caused by installation or operating errors.
The latest version of the operating instructions are available on our homepage.**

Supplementary information



Fig. 1: Please read!

Read the following supplementary information in its entirety! You will benefit more from the operating instructions should you already know this information.

The following are highlighted separately in the document:

- Enumerated lists

➔ Instructions

⇒ Outcome of the instructions

🔗 *'State the identity code and serial number' on page 2*: Links to points in this chapter

- refer to ... : References to points in this document or another document

[Keys]

'Menu level 1 → Menu level 2 → Menu level ...': Menu paths

'Software interface texts'

Information



This provides important information relating to the correct operation of the unit or is intended to make your work easier.

Safety information

Safety information is identified by pictograms - see "Safety Chapter".

State the identity code and serial number

Please state the identity code and serial number, which you can find on the nameplate or in the menu under *'Setting / Menu → Information'* when you contact us or order spare parts. This enables us to clearly identify the unit type and material version.

General non-discriminatory approach

In order to make it easier to read, this document uses the male form in grammatical structures but with an implied neutral sense. It is aimed equally at both men and women. We kindly ask female readers for their understanding in this simplification of the text.

Table of contents

1	About this pump	6
2	Identity code	7
3	Safety chapter	10
	3.1 Intended use.....	11
	3.2 Safety information.....	11
	3.3 Isolating protective equipment.....	13
	3.4 Other protective equipment.....	13
	3.5 Information in the event of an emergency.....	13
	3.6 Qualification of personnel.....	14
	3.7 Sound pressure level.....	14
4	Storage, transport and unpacking	15
5	Overview of equipment and control elements	16
	5.1 Overview of equipment.....	16
	5.2 Control elements.....	17
	5.2.1 Control elements.....	17
	5.2.2 Key functions.....	19
6	Functional description	20
	6.1 Unit.....	20
	6.2 Dosing rate.....	20
	6.3 Operating modes.....	20
	6.4 Functions.....	20
	6.5 Relays (options).....	21
	6.6 LED displays.....	21
	6.7 Hierarchy of operating modes, functions and fault statuses.....	22
7	Assembly	23
	7.1 Changing the dosing head alignment.....	23
8	Installation, hydraulic	26
9	Installation, electrical	28
	9.1 Supply voltage connector - mains voltage.....	29
	9.2 Description of the terminals.....	29
	9.2.1 "Config I/O" socket.....	29
	9.2.2 "External control" terminal.....	30
	9.2.3 "Level switch" terminal.....	32
	9.2.4 "Metering monitor" terminal.....	32
	9.2.5 "Tube rupture indicator" terminal.....	33
	9.2.6 Relays.....	33
10	Basic set-up principles	37
	10.1 Basic principles for setting up the control.....	37
	10.2 Checking adjustable variables.....	39
	10.3 Changing to Setting mode.....	39
11	Initial commissioning	40
12	Set up / 'Menu'	43
	12.1 'Information'.....	43
	12.2 'Settings'.....	43
	12.2.1 'Operating mode'.....	44
	12.2.2 Dosing direction.....	47
	12.2.3 Concentration.....	47
	12.2.4 Calibration.....	52
	12.2.5 System.....	54
	12.2.6 Config-I/Os.....	55
	12.2.7 Inputs/outputs.....	56

12.2.8	<i>'Priming time'</i>	58
12.2.9	<i>'Set time'</i>	59
12.2.10	<i>'Date'</i>	59
12.3	<i>'Tube service'</i>	59
12.4	Timer.....	59
12.4.1	Activation / deactivation.....	60
12.4.2	Setting the timer.....	60
12.4.3	Clear all.....	66
12.4.4	Examples.....	66
12.4.5	Timer information.....	67
12.4.6	Typical pitfalls Timer functional faults.....	67
12.4.7	Brief explanation of selected functions.....	68
12.5	<i>'Service'</i>	68
12.5.1	<i>'Access protection'</i>	69
12.5.2	<i>'Password'</i>	70
12.5.3	<i>'Clear counters'</i>	70
12.5.4	<i>'Hose'</i>	70
12.5.5	<i>'Error log book'</i>	71
12.5.6	<i>'Display'</i>	72
12.5.7	<i>'Factory setting'</i>	72
12.5.8	Spare parts kit number: XXXXXXXX.....	72
12.6	<i>'Language'</i>	72
13	Operation	73
13.1	Manual operation.....	73
14	Maintenance	75
15	Repair	76
15.1	Replacing the pump hose.....	76
15.2	Cleaning the hose rupture indicator (optional).....	78
16	Rectifying functional faults	79
16.1	Faults without error message.....	79
16.2	Fault with error message.....	79
16.2.1	Fault messages on the LCD screen.....	79
16.2.2	Warning messages on the LCD screen.....	81
16.2.3	All other faults.....	81
16.3	Log book.....	81
16.3.1	Fault messages in the log book.....	81
16.3.2	Warning messages in the log book.....	83
16.3.3	Event messages in the log book.....	83
16.3.4	Log book entry - detailed view.....	84
17	Decommissioning and disposal	85
18	Technical data	86
18.1	Performance data.....	86
18.2	Precision.....	86
18.3	Viscosity.....	86
18.4	Material specifications.....	87
18.5	Electrical data.....	87
18.6	Temperatures.....	87
18.7	Climate.....	88
18.8	Altitude of site.....	88
18.9	Degree of protection and safety requirements.....	88
18.9.1	Degree of protection.....	88
18.9.2	Safety requirements.....	88
18.9.3	Degree of pollution.....	88
18.10	Sound pressure level.....	88
18.11	Suction lance, continuous.....	88

19	Dimensional drawings.....	90
20	Diagrams for adjusting the pump capacity.....	91
21	Declaration of Conformity for Machinery.....	92
22	UK Declaration of Conformity.....	93
23	Operating / set-up overview DULCO flex Control - DFXa.....	94
24	DULCO flex Control - DFXa operating menu, overall.....	96
25	Continuous displays and secondary displays.....	101
26	Installation instructions: Retrofitting, relays.....	103
27	Index.....	104

1 About this pump

About this pump

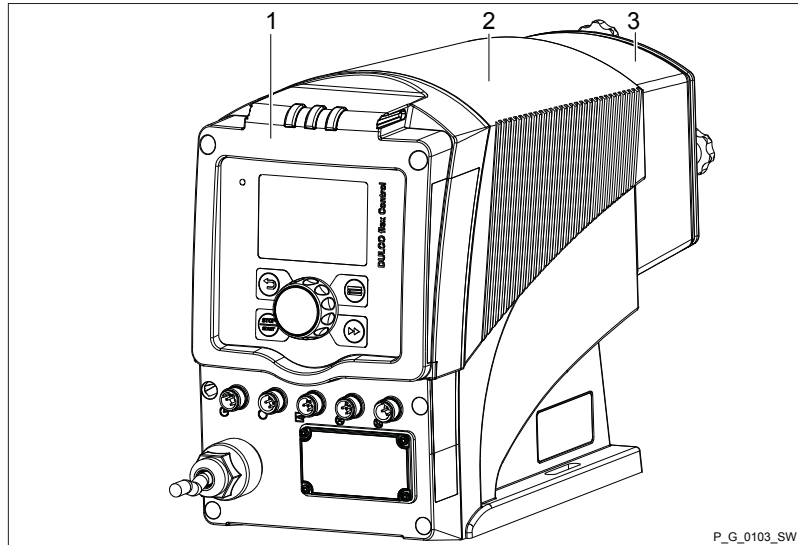

Fig. 2: Overview of equipment of the DFXa, complete

- 1 Control unit
- 2 Drive unit
- 3 Liquid end

Pumps in the DULCO flex Control - DFXa product range are microprocessor-controlled peristaltic metering pumps with the following characteristics:

- Adjustment of the dosing rate directly in l/h or gph
- Reverse flow is possible
- by software-supported hose change
- Sole contact with media in the hose
- CIP (cleaning in place)-compatible when the pump is running
- Direct input of the desired concentration in concentration mode with volume-proportional metering tasks
- External control via potential-free contacts with pulse step-up and step-down
- External control via 0/4-20 mA standard signal, scalable
- Integrated 1-week/1-month timer
- Connection to process control systems via a BUS interface, such as PROFIBUS, PROFINET, Modbus RTU or CANopen bus
- DULConneX-compatible

2 Identity code



Product identification

This identity code serves to identify the product.

Use the identity code from the Product Catalogue for orders.

Product range DULCO flex Control - DFXa

DFXa

Regional design

EU Europe

US USA

CN China

Pump type

0530 5 bar, 30 l/h

0730 7 bar, 30 l/h

0365 3 bar, 65 l/h

0565 5 bar, 65 l/h

Tube material / Connectors / O-rings

SP TPV / PVDF / PTFE

VP PUR / PVDF / PTFE

FP SEBS (SEBS/PVDF) for NaOCl, H₂O₂, H₂SO₄, for type 0365 only

Seal material

T PTFE

F FDA-compliant (PTFE)

Dosing head orientation (view from behind)

R right

L left

U top

D bottom

Hydraulic connector

0 Standard connector (12x9)

2 8x5 connector

5 12x6 connector, discharge side

7 without connector kit

8 9x5 connector

E DN10 connector with nozzle

Tube rupture indicator

0 none

1 optical hose rupture indicator

Design

Product range DULCO flex Control - DFXa

0	housing RAL5003 / hood RAL2003	
2	housing RAL5003 / hood RAL3001	
M	modified	
Logo		
0	with ProMinent logo	
2	without ProMinent logo	
Design of power unit		
U	100-240 V	
Cable and plug		
A	2 m, Europe	
B	2 m, Switzerland	
C	2 m, Australia	
D	2 m, USA / 115 V	
1	2 m, open end	
..	...	
Relay function		
0	no relay	-
1	1 x changeover contact 230 V AC, 6 A	Fault indicating relay normally closed (N/C)
4	1 x N/O 24 V DC, 1 A 1 x N/O 24 V DC, 100 mA	as 1 + pacing relay
C	1 x N/O 24 V DC, 100 mA, and 1 x 4 ... 20 mA output	As 1 + 4 ... 20 mA output
..	...	
Accessories		
0	no accessories	
1	with 1/2" injection valve and foot valve	
5	as 1 + universal control cable	
7	as 1 + ball valve (FKM seals)	
Control version		
0	Manual + external contact with pulse control	
3	Manual + external contact with pulse control + ana- logue 0/4-20 mA	
C	As 3 + CANopen	
P	As 3 + PROFINET	
R	As 3 + PROFIBUS®, M12 plug	
M	As 3 + Modbus RTU	
Communication		
0	none	
B	Bluetooth	
Language		

3 Safety chapter



Cessation of statutory warranty claims

Do not open the unit! We would advise that the unit may only be opened by qualified personnel authorised by ProMinent to avoid damage to the unit and guarantee the seamless and safe operation of the unit. All warranty claims will be invalidated if the unit is opened by unauthorised persons. You forfeit warranty claims and claims for damages against ProMinent for damage caused by unauthorised persons opening the unit.

Identification of safety notes

The following signal words are used in these operating instructions to denote different severities of danger:

Signal word	Meaning
WARNING	Denotes a possibly dangerous situation. If this is disregarded, you are in a life-threatening situation and this can result in serious injuries.
CAUTION	Denotes a possibly dangerous situation. If this is disregarded, it could result in slight or minor injuries or material damage.

Warning signs denoting different types of danger

The following warning signs are used in these operating instructions to denote different types of danger:

Warning signs	Type of danger
	Warning – automatic start-up.
	Warning – hand injuries.
	Warning – high-voltage.
	Warning – danger zone.

3.1 Intended use



NOTICE!

Wear caused by "Pump ON/OFF" using the mains connection

Frequent switching of the pump on and off (>2 times each day) using the supply voltage leads to increased wear in the pump. The pump is not technically designed for this.

If necessary, use the "Pause" function to switch the pump to standby mode. Do not switch the pump on and off using the supply voltage to spare a pause input.

- Only use the pump to meter liquid feed chemicals.
- The protection provided by the pump can be impaired if this pump is used in a manner not specified in the operating instructions.
- Only use the pump once it has been correctly installed and started up in accordance with the technical data and specifications contained in the operating instructions.
- Observe the general limitations with regard to viscosity limits, chemical resistance and density- see also the ProMinent Resistance List in the product catalogue or at www.prominent.com. Use the "Resistance List for DULCO flex Control DFXa and DFYa" available at www.prominent.com for the pump hose.
- All other uses or modifications are prohibited.
- The pump is neither a gas pump nor a solids pump.
 - In spite of this, gas bubbles in the feed chemical and particles with a diameter of up to 1/3 of the inner diameter of the hose can be pumped.
- The pump is not designed to meter flammable media.
- The pump is not designed to meter explosive media.
- The pump is not designed for use outdoors, without appropriate protective measures.
- Only allow the pump to be operated by trained and authorised personnel - see the following "Qualifications" table.
- You have a duty to observe the information contained in the operating instructions during the different phases of the unit's service life.

3.2 Safety information



WARNING!

Warning about personal and material damage

The pump can start to pump, as soon as it is connected to the mains voltage.

- Install an emergency cut-off switch in the pump power supply line or integrate the pump in the emergency cut-off management of the system.



WARNING!

Warning of personal injury and material damage

The pump can start pumping as soon as it has cooled down after the error '*temperature*'.

- Take this into account with the pump and your installation.



WARNING!

Danger of electric shock

Supply voltage may be present inside the pump housing.

- Safely and quickly disconnect the pump from the mains/power supply if the pump housing has been damaged.
Only return the pump to operation after an authorised repair.



WARNING!

Warning of hazardous feed chemical

Should a dangerous feed chemical be used: it may escape from the hydraulic components when working on the pump, material failure or incorrect handling of the pump.

- Take appropriate protective measures before working on the pump (e.g. safety glasses, safety gloves, ...). Adhere to the material safety data sheet for the feed chemical.
- Drain and flush the liquid end before working on the pump.



WARNING!

Danger from hazardous substances!

Possible consequence: Fatal or very serious injuries.

Please ensure when handling hazardous substances that you have read the latest safety data sheets provided by the manufacture of the hazardous substance. The actions required are described in the safety data sheet. Check the safety data sheet regularly and replace, if necessary, as the hazard potential of a substance can be re-evaluated at any time based on new findings.

The system operator is responsible for ensuring that these safety data sheets are available and that they are kept up to date, as well as for producing an associated hazard assessment for the workstations affected.



CAUTION!

Warning of feed chemical spraying around

Feed chemical may spray out of the hydraulic components if they are tampered with or opened due to pressure in the liquid end and adjacent parts of the system.

- Disconnect the pump from the mains power supply and ensure that it cannot be switched on again by unauthorised persons.
- Ensure that the system is at atmospheric pressure before commencing any work on hydraulic parts of the system.



CAUTION!

Danger of injury to personnel and material damage

The use of untested third party components can result in injury to personnel and material damage.

- Only fit parts to metering pumps that have been tested and recommended by ProMinent.

An unsuitable feed chemical may cause premature wear of the pump hose.

- Pay attention to the resistance of the pump hose and the "Resistance List for DULCO flex Control DFXa and DFYa" available at www.prominent.com when selecting the feed chemical.

Risk of body parts being drawn in

- The rotor running in the liquid end can draw in and trap body parts.
- Do not reach into the running rotor.
- Only remove the bearing cover once prompted to do so by the operating instructions or the operating software.

3.3 Isolating protective equipment

- Cover of the slot for relays and optional modules - see the chapter entitled "Overview of equipment and control elements"
- Bearing cover for the liquid end - see "Overview of equipment and control elements" chapter

INFORMATION: The bearing cover only prevents people from reaching into the rotor; it is not liquid-tight.

Customers should only remove the cover of the slot for relays and optional modules and/or a relay or optional module in line with the supplementary instructions for the relays and optional modules.

Customers should only remove the bearing cover for the liquid end in accordance with the "Repair" chapter.

Only ProMinent Service is authorised to open the housing and hood (housing the control elements).

3.4 Other protective equipment

Labels

- A warning sign indicating "Warning of injury to hands" is attached to the pump and warns of rotating parts and the risk of being drawn into the liquid end.
- Ensure that the label is always fitted and legible.

Star-shaped handle with locking nut

- The bearing cover of the liquid end is fixed in place with 4 star-shaped screws. 1 star-shaped screw is secured with a locking nut to prevent unintentional opening.

3.5 Information in the event of an emergency

In an emergency, either disconnect the mains plug, press the  [Start/Stop] key or press the Emergency Stop switch installed by the customer, or disconnect the pump from the mains/power supply in line with the Emergency Stop management guidelines for your system.

If feed chemical escapes, ensure that the hydraulic environment around the pump is also at atmospheric pressure. Pay attention to the material safety data sheet for the feed chemical.

3.6 Qualification of personnel

Qualification of personnel

Task	Qualification
Storage, transport, unpacking	Instructed person
Assembly	Technical personnel, service
Planning the hydraulic installation	Technical personnel who have a thorough knowledge of peristaltic pumps
Hydraulic installation	Technical personnel, service
Electrical installation	Electrical technician
Initial commissioning	Technical personnel, service
Operation	Instructed person
Maintenance, repair	Technical personnel, service
Decommissioning, disposal	Technical personnel, service
Troubleshooting	Technical personnel, electrical technician, instructed person, service

Explanation of the table:

Technical personnel

Technical personnel are deemed to be people who are able to assess the tasks assigned to them and recognise possible dangers based on their technical training, knowledge and experience, as well as knowledge of pertinent regulations.

Note:

A qualification of equal validity to a technical qualification can also be gained by several years of employment in the relevant field of work.

Electrical technician

An electrical technician is able to complete work on electrical systems and recognise and avoid possible dangers independently based on his or her technical training and experience as well as knowledge of pertinent standards and regulations.

The electrical technician must be specifically trained for the working environment in which he or she is employed and be conversant with the relevant standards and regulations.

The electrical technician must comply with the provisions of the applicable statutory directives on accident prevention.

Instructed person

An instructed person is deemed to be a person who has been instructed and, if required, trained in the tasks assigned to him/her and possible dangers that could result from improper behaviour, as well as having been instructed in the required protective equipment and protective measures.

Service

The service department refers to service technicians, who have received proven training and have been authorised by ProMinent to work on the device / system.

3.7 Sound pressure level

Sound pressure level

Sound pressure level LpA < 70 dB in accordance with EN ISO 20361, at maximum dosing rate and maximum back pressure (water).

4 Storage, transport and unpacking

User qualification: Instructed person - see  'Qualification of personnel' on page 14

Safety information



WARNING!

Only return metering pumps for repair in a cleaned state and with a flushed liquid end - refer to "Decommissioning!"

Only return metering pumps with a completed Decontamination Declaration form. The Decontamination Declaration constitutes an integral part of an inspection / repair order. A unit can only be inspected or repaired when a Declaration of Decontamination Form is submitted that has been completed correctly and in full by an authorised and qualified person on behalf of the pump operator.

The "Decontamination Declaration Form" can be found on our homepage.



CAUTION!

Danger of material damage

The device can be damaged by incorrect or improper storage or transportation!

- The unit should only be stored or transported in a well packaged state - preferably in its original packaging.
- The packaged unit should also only be stored or transported in accordance with the stipulated storage conditions.
- The packaged unit should be protected from moisture and the ingress of chemicals.



CAUTION!

Before shipping

Remove the pump hose from the pump before shipping.

Ambient conditions

Ambient conditions - see "Technical data" chapter.

Storage period, max.

Storage period of pump hose non-condensing, max.: 2 years

Scope of delivery

Compare the delivery note with the scope of delivery:

- Metering pump with mains cable
- Pump hose
- Rotor half
- Product-specific operating instructions with EU Declaration of Conformity
- Optional accessories

5 Overview of equipment and control elements

5.1 Overview of equipment

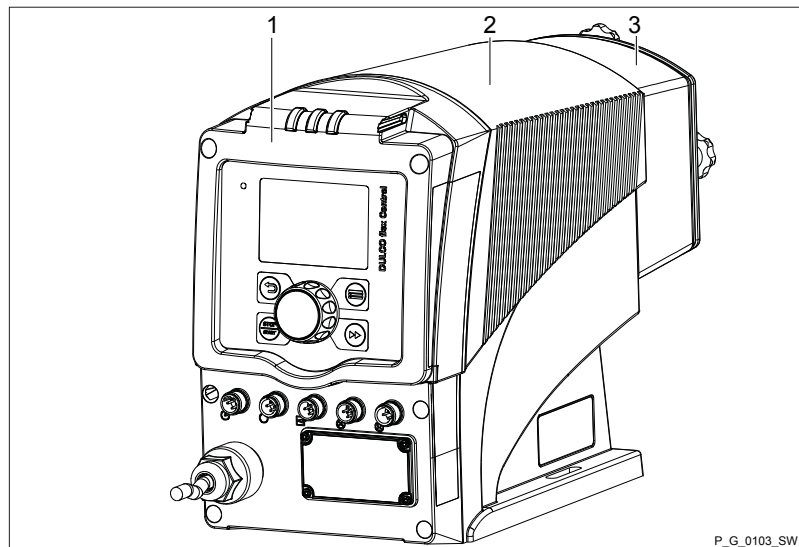

Fig. 3: Overview of equipment of the DFXa, complete

- 1 Control unit
- 2 Drive unit
- 3 Liquid end

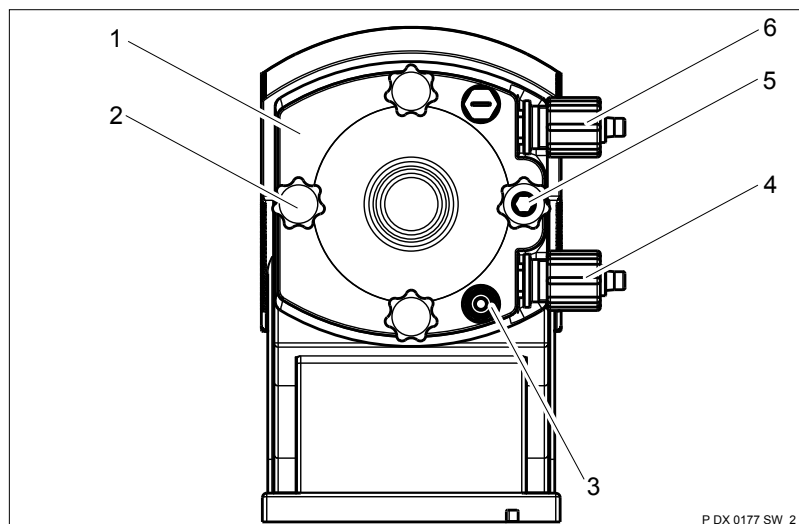

Fig. 4: Liquid end DFXa

- 1 Dosing head
- 2 Star-shaped screw
- 3 Insert for hose rupture sensor
- 4 Suction connector
- 5 Domed nut on star-shaped screw
- 6 Pressure connector

5.2 Control elements

Control elements, overview

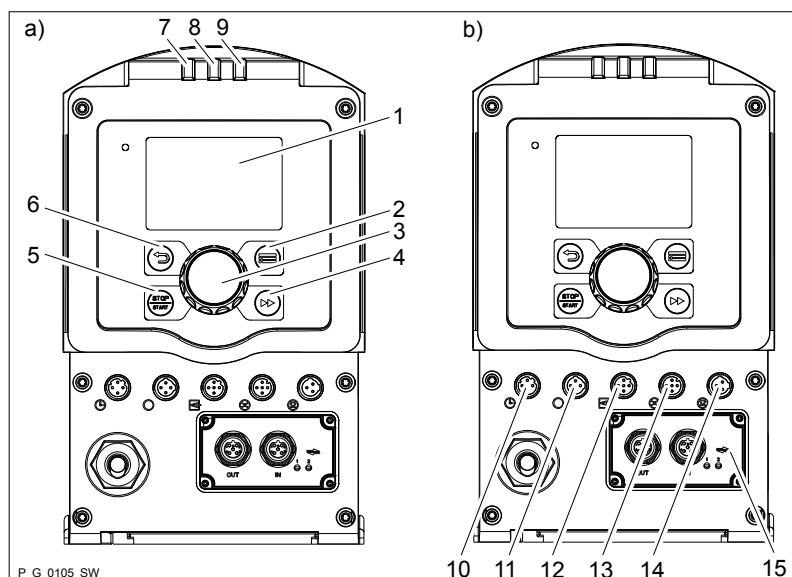

Fig. 5

- 1 LCD screen
- 2 [Menu] key
- 3 Clickwheel
- 4 [Priming] key
- 5 [STOP/START] key
- 6 [Back] key
- 7 Fault indicator (red)
- 8 Warning indicator (yellow)
- 9 Operating indicator (green)
- 10 "Config-I/O" terminal
- 11 "Hose rupture indicator" terminal
- 12 "External control" terminal
- 13 "Metering monitor" terminal (no function)
- 14 "Level switch" terminal
- 15 Slot for relays and optional modules

5.2.1 Control elements

Identifier and fault displays on the LCD screen

Familiarise yourself with the keys and other control elements of the pump.

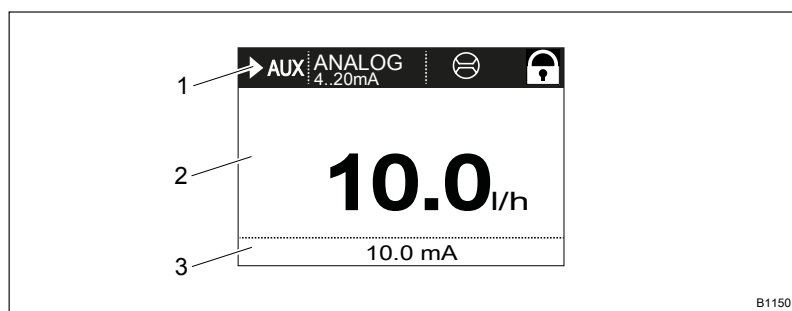

Fig. 6: Layout of the continuous display

- 1 Status bar
- 2 Continuous display, central area
- 3 Secondary display

Refer to the chapter entitled "Main displays and secondary displays" in the Appendix for the different main displays and secondary displays.

The LCD screen supports the operation and adjustment of the pump using different information and identifiers:

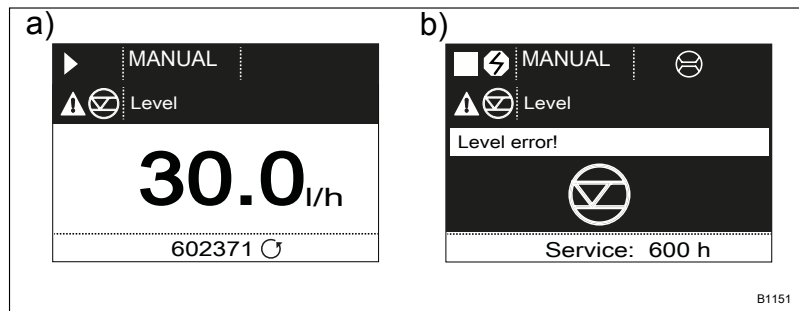













Fig. 7: a) Continuous display with warning message; b) Continuous display with fault message. Explanation of the symbols in the following tables.

Figure:

- Fig. 7 part a) shows that:
- the pump is in operation
- is in 'Manual' operating mode
- a 'Level' warning message is pending
- the dosing rate of 30.0 l/h has been set
- the pump has performed 602371 revolutions to date

Tab. 1: Identifiers and error displays:







Identifier	Meaning
	The pump is working or waiting for a starting signal.
	The pump was manually stopped using the  [STOP/START] key.
	The pump was remotely stopped (Pause) via the "External" terminal.
	The pump was stopped by an error.
	Only with cyclical batch metering: the pump is waiting for the next cycle.
	Only with 'Access protection': the pump software is locked.
'AUX'	The pump is currently pumping at auxiliary dosing rate.
'memory'	Only in 'CONTACT' and 'BATCH' operating modes: the auxiliary function "Memory" has been set.
	The pump is in 'ANALOG' operating mode. The 'Curve → linear' type of processing is set.
	The pump is in 'ANALOG' operating mode. The 'Curve → Upper side band' type of processing is set.

Identifier	Meaning
	A hose rupture indicator is connected.
	The pump is in the 'Menu' (Set up).

Further explanations can be found in the "Troubleshooting" chapter.

The pump only shows the metering volume and the dosing rate in a calibrated state in l or l/h or in gal or gal/h (US gallons).

5.2.2 Key functions

Key	Application	In the continuous displays	In the menu
 [Back]	press	-	Go back to the previous menu item (or a continuous display) - without saving
 [STOP/START]	press	Stop pump, Start pump	Stop pump, Start pump
 [Menu]	press	Go to the menu	Go back to a continuous display
 [Priming]	press	Priming *	Priming *
 [Clickwheel]	press	Start batch (only in 'Batch' operating mode). Acknowledge error	Go to next menu item (or a continuous display) Confirm entry and save
 [Clickwheel]	turn	Switch between the continuous displays	Change figure or change selection

* When priming the pump does not run at the maximum number of revolutions.

If  [Priming] is pressed in 'Stop' status, then [Priming] has top priority as long as the key is pressed.

Refer to the "Set-up basics" chapter for information on how to adjust figures

6 Functional description

6.1 Unit

An electric motor drives a rotor. Rollers are fitted to the ends of the rotors, which press the pump tube against the inner curvature of the dosing head. The peristaltic pump operates by the rollers driving the feed chemical through the pump tube. The feed chemical is primed by the pump tube automatically returning to its initial position.

The pump is therefore capable of pumping particles up to a diameter of 1/3 of the inner tube diameter or gas bubbles.

6.2 Dosing rate

The pump itself regulates the dosing rate that has been set.

6.3 Operating modes

Operating modes are selected via the "Operating modes" menu.

Refer to the "Hierarchy of Operating Modes, Functions and Fault Statuses" for the order of the various operating modes, functions and fault statuses.

"Manual" operating mode

'Manual' operating mode permits you to operate the pump manually.

"Contact" operating mode

This operating mode provides the option of controlling the pump externally by means of potential-free contacts (e.g. by means of a contact water meter). "Pulse Control" can be used to preselect the metering volume in the *'Settings'* menu.

"Batch" operating mode

This operating mode provides the option of working with large metering volumes. Metering can be triggered either by pressing the *[Clickwheel]* or by a pulse received via the "External control" terminal via a contact or a semiconductor switching element. It is possible to pre-select a metering volume (batch) and a metering time using the *[Clickwheel]* in the *'Settings'* menu.



"Analog" operating mode

The capacity is controlled using an analogue current signal via the "External control" terminal. Processing of the current signal can be preselected using the control unit.

6.4 Functions

Refer to the "Hierarchy of Operating Modes, Functions and Fault Statuses" for the order of the various operating modes, functions and fault statuses.

The following functions can be selected using the *'Settings'* menu:

"Calibrate" function	Calibrate the pump if you wish good precision when metering high-viscosity feed chemicals.
"Auxiliary capacity" function	This facilitates the switch-over to a fixed adjustable capacity in the 'menu' via the "External control" socket.
"Timer" function	This permits a simple timer program to be set up without the need for an additional timer module. The following functions are available as standard:
"Level switch" function	Information about the liquid level in the dosing tank is reported to the pump. A two-stage level switch has to be fitted for this purpose, which is connected to the "Level switch" socket. A suction lance with continuous level measurement can also be connected to the pumps.
"Pause" function	The pump can be remotely stopped via the "External control" socket.
"Stop" function	The pump can be stopped without disconnecting it from the mains/power supply by pressing  [STOP/START].
"Priming" function	Priming can be triggered by pressing  [Priming].

6.5 Relays (options)

The pump has several connecting options available:

"Fault indicating relay" option	The relay can close a connected power circuit (e.g. for an alarm horn) in the event of warnings or fault messages (e.g. 'Warning level'). The relay can be retrofitted through the slot in the front of the pump – refer to the installation instructions for "Retrofitting relays".
"Fault indicating and pacing relay" option	This combined relay can generate a contact for an adjustable volume via its pacing relay in addition to functioning as a fault indicating relay. The relay can be retrofitted through the slot in the front of the pump.
"mA-Output" option	The current output signal I indicates the pump's actual calculated metering volume. The relay can be retrofitted through the slot in the front of the pump. The option also always includes a fault indicating relay or a pacing relay.

6.6 LED displays

LED display	Colour	lit	lights up	flashes
Fault indicator	red	A fault message is pending	-	undefined operating status
Warning indicator	yellow	A warning message is pending	-	-

LED display	Colour	lit	lights up	flashes
Operating display	green	The pump is ready for operation	-	-
			During every revolution: dosing rate greater than 10 l / h	-
			During every 1/2 revolution: dosing rate less than 10 l / h	-
			During every 1/8 revolution: dosing rate less than 1 l / h	-
			every 4 s: dosing rate less than 500 ml / h	-

6.7 Hierarchy of operating modes, functions and fault statuses

The different operating modes, functions and fault statuses have a different impact on whether and how the pump reacts.

The following list shows the order:

1. - Priming
2. - Stop
3. - Error, Pause
4. - Auxiliary capacity
5. - Manual, Analog, Contact, Batch, Fieldbus

Comments:

re 1. - "Priming" can take place in any pump mode (providing it is working).

re 2. - "Stop" stops everything.

re 3. - "Error", and "Pause" stop everything apart from "Priming".

re 4. - "Auxiliary capacity" always has priority over the capacity specified by an operating mode listed under 5 or the fieldbus.

7 Assembly

User qualification: technical personnel and service - see ⓘ 'Qualification of personnel' on page 14



Refer to the correct dimensional drawings for the pump from the online version of the operating instructions on our website. www.prominent.com



Compare the dimensions on the dimensional drawing with those of the pump.



CAUTION!

Danger from incorrectly operated or inadequately maintained pumps

Danger can arise from a poorly accessible pump due to incorrect operation and poor maintenance.

- Ensure that the pump is accessible at all times.
- Adhere to the maintenance intervals.

7.1 Changing the dosing head alignment

The dosing head can be aligned in 4 directions:

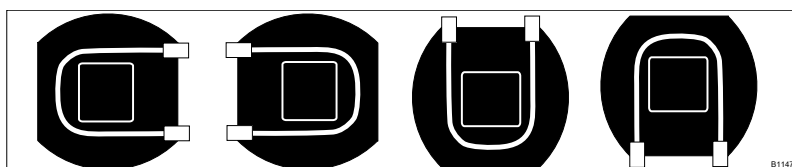

Fig. 8: Alignment of the dosing head: to the right, to the left, up, down

Proceed as follows to change the alignment of the dosing head:

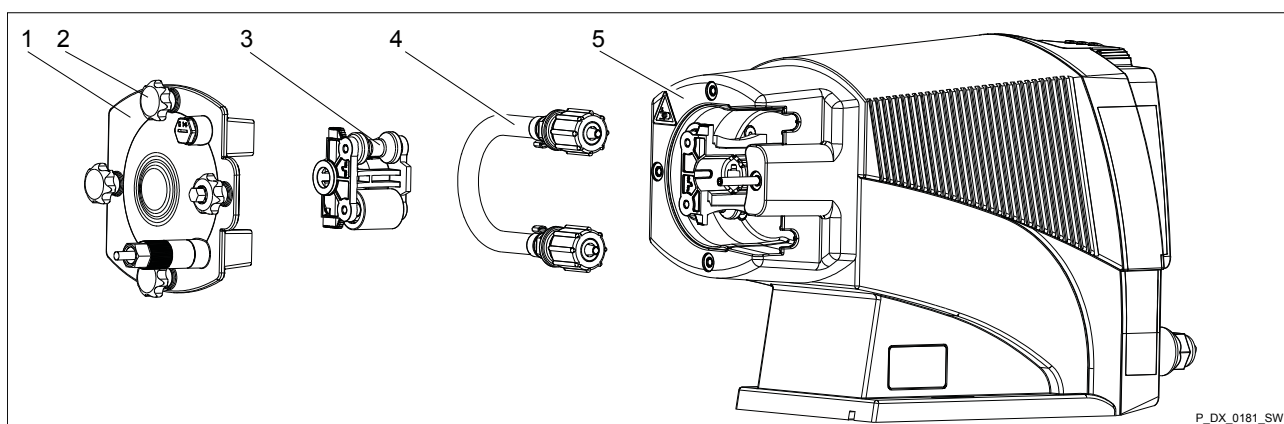



Fig. 9

- Ensure that the system is at atmospheric pressure.
- Adhere to the material safety data sheet for the feed chemical.

- Prevent the escape of feed chemical.
 - If necessary take protective measures.
1. ▶ Press  [STOP/START] to bring the pump to a stop (manually).
 2. ▶ Empty the liquid end (turn the liquid end upside down and allow the feed chemical to run out; flush out with a suitable medium; flush the liquid end thoroughly when using hazardous feed chemicals!).
 3. ▶ Go to the  → 'Tube Service' menu.
 - ⇒ 'Go to change position?' appears.



WARNING!

The rotating rotor may crush things or draw them in.

- Do not remove the bearing cover yet.

4. ▶ Confirm the prompt with 'Yes'.
 - ⇒ The rotor turns slowly and the following appears:
'Please wait...'
The rotor stops and *'Remove cover and take out the rotor!'* appears (the corresponding rotor half flashes in the animation).
5. ▶ Loosen the 4 star-shaped screws (2) on the dosing head (6) and remove with the bearing cover (1).
6. ▶ Pull the rotor half (3) flashing in the LCD screen out of the dosing head (6) (if required, use a plastic tool to release it).
7. ▶ Press the Clickwheel.
 - ⇒ The rotor turns slowly and the following appears:
'Please wait...'
The rotor stops and *'Please change the tube!'* appears.
8. ▶ Snap the two hydraulic connectors out of the dosing head (5) - away from pump - and remove along with the tube (4).
9. ▶ Also pull the 2nd half of the rotor (5) out of the dosing head (6).
10. ▶ Remove the 4 Torx screws from the rear of the dosing head.
11. ▶ Align the dosing head as required (to the left, to the right, up, down).
12. ▶ Replace the 4 Torx screws and manually tighten them.
13. ▶ Place the 2nd half of the rotor (5) on the drive axle in the dosing head with "This side DOWN" surface facing downwards - the rollers must point towards the recesses for the hydraulic connectors.
14. ▶ Insert the tube (4) into the dosing head (5) and snap the two hydraulic connectors into place - round side in the dosing head (5).
15. ▶ Press the Clickwheel.
 - ⇒ The rotor turns slowly and the following appears:
'Please wait!'
The rotor stops and *'Insert rotor again!'* appears.
16. ▶ Replace the 1st half of the rotor (3) - the surfaces of the two rotor halves must be perfectly flush.
17. ▶ Press the Clickwheel.
 - ⇒ The rotor turns and the following appears:
'Please wait...'
The rotor stops and *'Install Cover again!'* appears.
18. ▶ Place the bearing cover (1) on the dosing head (6).
19. ▶ Initially only loosely screw all 4 star-shaped screws (2) into the dosing head (6).

20. ▶ Manually tighten the 4 star-shaped screws (2).
Screw the domed nut onto the 4th star-shaped screw again and tighten it to provide a locking function.
21. ▶ Press the Clickwheel.
⇒ 'Run in tube?' appears.
'Yes' / 'No'
22. ▶ Selecting [No] exits this macro.
23. ▶ You can return to the continuous display by pressing  → .



If the dosing direction is also to be reversed, this can be done by going to the 'Settings → Dosing direction → ...' menu.

8 Installation, hydraulic

User qualification: technical personnel and service - see  'Qualification of personnel' on page 14



CAUTION!

Danger of injury to personnel and material damage

The use of untested third party components can result in injury to personnel and material damage.

- Only fit parts to metering pumps that have been tested and recommended by ProMinent.

Safety information

Spraying feed chemical



- An unsuitable feed chemical may cause premature wear of the pump hose.
- Pay attention to the resistance of the pump hose and the "Chemical Resistance List for DFXa" available at www.prominent.com when selecting the feed chemical.

Spraying feed chemical

- The lines can become loose or rupture if they are not installed correctly.
- Route all hose lines so that they are free from mechanical stresses and kinks.
- Only use original hoses with the specified hose dimensions and wall thicknesses.
- Only use clamp rings and hose sleeves intended for the respective hose diameter to ensure the long service life of the connections.

Installing hose lines

Before commencing all work

1.  De-energise the pump.
2.  Ensure that the pump is at atmospheric pressure.
3.  If need be, then use a suitable flushing medium to flush the pump, referring to the material safety data sheet.

Installing the suction and pressure line:

Arrange the lines so that the metering pump and the liquid end can simply be removed if necessary.

1.  First test which is the suction connector and which is the pressure connector:

In 'Manual' 'operating mode', briefly press  [STOP/START] and observe the rotor:

The rotor rotates away from the suction connector and towards the pressure connector.

If this arrangement is inappropriate, you can change it via the dosing direction in the 'Settings → Dosing direction → ...' menu.

2.  Connect the suction line and the pressure line as described below.

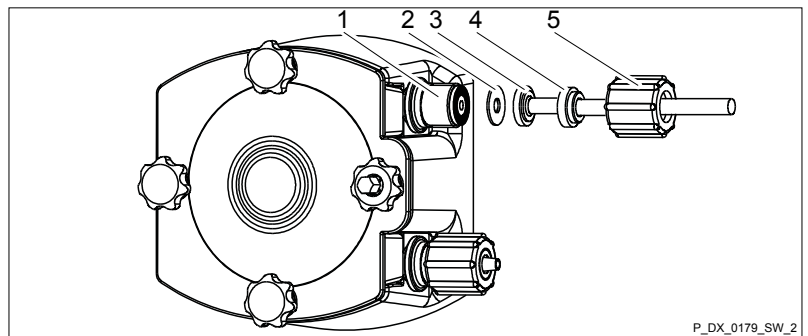

P_DX_0179_SW_2

Fig. 10: Installing the suction and dosing line

3. ➤ Shorten the end of the hose at right angles.
4. ➤ Unscrew the union nut (2) and slide the union nut over the hose (3).
5. ➤ Push the hose end over the hose connector (4) as far as the stop.
Never re-use used PTFE seals.
An installation sealed in this way is not leak-tight. These seals are permanently distorted when compressed.
6. ➤ Tighten the union nuts.
7. ➤ If you are only using a hose line and no suction lance: shorten the free end of the suction line so that the end of the suction line hangs just above the base of the feed chemical tank.

9 Installation, electrical

User qualification: electrical technician ↻ 'Qualification of personnel' on page 14



WARNING!

Risk of electric shock

In the event of an electrical accident, the pump must be quickly disconnected from the mains.

- Install an emergency cut-off switch in the pump power supply line or
- Integrate the pump in the emergency cut-off management of the system and inform personnel of the isolating option.

Incompletely installed electrical options can allow moisture to penetrate into the housing.

- Fit appropriate modules into the slot on the front of the pump or use the original blank cover to seal it in a leak-tight manner.
- A suitable PROFIBUS® plug or protective cap must be screwed onto PROFIBUS® sockets.



WARNING!

Danger of electric shock

Supply voltage may be present inside the pump housing.

- Safely and quickly disconnect the pump from the mains/power supply if the pump housing has been damaged.
Only return the pump to operation after an authorised repair.



CAUTION!

Material damage possible due to power surges

If the pump is connected to the mains power supply in parallel to inductive consumers, then inductive power surges from consumers, such as solenoid valves, motors etc., can damage the control when it is switched off.

- Provide the pump with its own contacts (phase) and supply these contacts with voltage via a contactor relay or relay.
- If need be, fit external overvoltage protection, e.g. for the socket or control cabinet.



CAUTION!

Bonding of the contacts of your switching relay

The high starting current can cause the contacts of the on-site switching relay to bond together if the mains voltage switches a solenoid metering pump on and off in a process.

- Use the switching options offered by the external socket to control the pump (functions: Pause, Auxiliary frequency or Operating modes: Contact, Batch, Analogue).
- Use a starting current limiter if it is impossible to avoid switching the pump on and off via a relay.

➔ Install the pump professionally and correctly and in accordance with the operating instructions and applicable regulations.

9.1 Supply voltage connector - mains voltage



WARNING!

Unexpected start-up is possible

The pump can start pumping and consequently feed chemical may escape as soon as the pump is connected to the mains/power supply.

- Avoid the escape of feed chemical.
- If you have not done so, immediately press *[STOP/START]* or disconnect the pump from the mains voltage e.g. using an Emergency Stop switch.
- Refer to the material safety data sheet for your feed chemical.



CAUTION!

If the pump is integrated into a system: Design the system so that potential hazardous situations are avoided by pumps starting up automatically subsequent to unintended power interruptions.



Simply disconnect the pump from the mains/power supply for repair or maintenance work, among other things.

- *With cables with plug: Provide adequate room around the socket provided.*
- *With cables without plug: Provide an appropriate, easily accessible On/Off switching option in your building installation.*

Highlight the disconnection option as such and inform staff about the electrical isolation option.

Connect the pump to the mains voltage using the mains cable.

9.2 Description of the terminals

9.2.1 “Config I/O” socket

There is an option to transmit the signals of 3 potential-free contacts as inputs I: to the pump via the “Config I/O” socket or issue contact signals as Outputs O:.

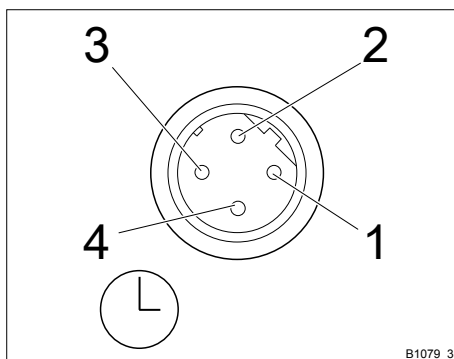

Fig. 11: “Config I/O” socket, pin assignment

Tab. 2: Pin assignment

Pin	Assignment	4-wire cable
1	Config I/O 1	brown
2	Config I/O 2	white
3	Config I/O 3	blue
4	GND	black

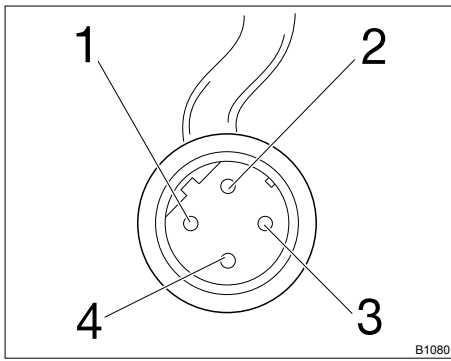

Fig. 12: Plug to "Config I/O" socket, pin assignment

Configured as an input

Parameter	Value
Voltage with open contacts	5 V
Input resistance	10 kΩ
Max. pulse frequency	50 pulses/s
Min. pulse duration	10 ms

Tab. 3: Control via:

Switching element	Specification
Potential-free contact	Load: 0.5 mA at 5 V
Semiconductor switch	Residual voltage < 2 V

Configured as an output

Parameter	Value
Max. pulse frequency	50 pulses/s
Min. pulse duration	10 ms

Switching element	Specification
NPN output (Open Drain)	30 V max. voltage and 300 mA max. current load per pin



CAUTION!

No protection provided for inductive loads.

- Provide a free-running diode when controlling a relay.

9.2.2 "External control" terminal

The "External control" terminal is a 5-pin panel terminal. It is compatible with 2- and 4-pin cables.

Only use a 5-pin cable with the "Auxiliary capacity" and "mA input" functions.

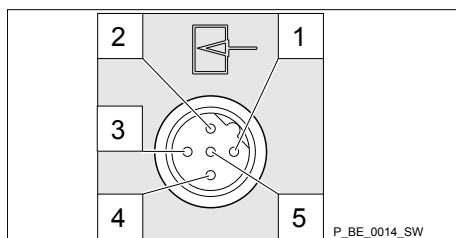

Fig. 13: Assignment on the pump

Electrical interface for pin 1 “Pause” - pin 2 “External contact” - pin 5 “Auxiliary capacity”

Data	Value	Unit
Voltage with open contacts	5	V
Input resistance	10	kΩ
Max. pulse frequency	25	pulse/s
Min. pulse duration	20	ms

Control via:

- potential-free contact (load: 0.5 mA at 5 V) or
- semiconductor switch (residual voltage < 0.7 V)

Electrical interface for pin 3 “mA input” (with identity code characteristic “Control version”: 2 and 3)¹

Data	Value	Unit
Input load, approx.	120	Ω

¹ The metering pump starts running at approx. 0.4 mA (4.4 mA) and reaches maximum capacity at approx. 19.6 mA.

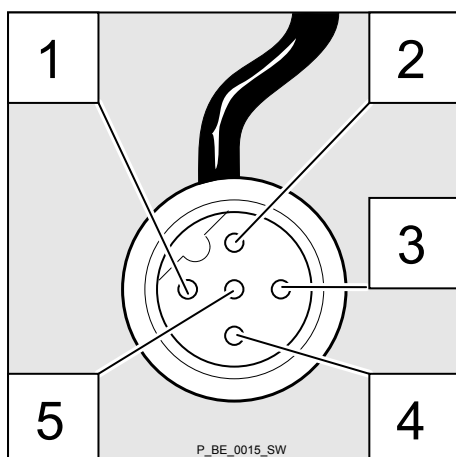

Fig. 14: Assignment on the cable

Pin	Function	5-wire cable	2-wire cable
1	Pause	brown	bridged at pin 4
2	External contact	white	brown
3	mA input*	blue	-
4	Earth GND	black	white
5	Auxiliary capacity	grey	-

* with identity code characteristic “Control version”: 3



Refer to the functional description for the sequence of functions and operating modes.

“Pause” function

The pump works if:

- pin 1 and pin 4 are connected to each other and the cable is connected.
- no cable is connected.

The pump does not work if:

- pin 1 and pin 4 are open and the cable is connected.



Acknowledging faults with ‘Pause’

Certain errors requiring acknowledgement can also be acknowledged using ‘Pause’ instead of using the Click-wheel.

“External Contact” operating mode

The pump performs one or more revolutions if:

- Pin 2 and pin 4 are connected to each other for at least 20 ms. At the same time, pin 1 and pin 4 must also be connected to each other.

“Analog” operating mode

The pump capacity and/or number of revolutions can be controlled by a current signal. The current signal is connected between pin 3 and pin 4. Pin 1 and pin 4 must also be connected.

“Auxiliary capacity” operating mode

The pump works at a pre-set capacity if:

- Pin 5 and pin 4 are connected to each other. At the same time, pin 1 and pin 4 must also be connected to each other. The auxiliary capacity is factory-pre-set to maximum capacity.

9.2.3 “Level switch” terminal

There is a connecting option for a 2-stage level switch with pre-warning and limit stop or a suction lance with continuous level measurement.

9.2.3.1 Suction lance with 2-stage level switch

Electrical interface

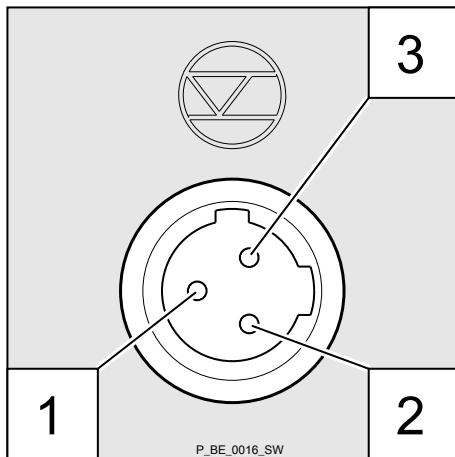

Data	Value	Unit
Voltage with open contacts	5	V
Input resistance	10	kΩ

Control via:

- potential-free contact (load: 0.5 mA at 5 V) or
- semiconductor switch (residual voltage < 0.7 V)

Fig. 15: Assignment on the pump

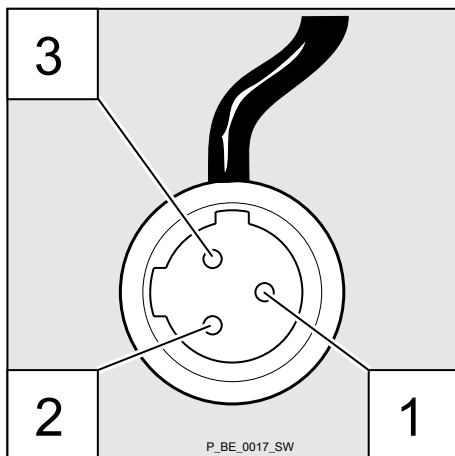

Pin	Function	3-wire cable
1	Earth GND	black
2	Minimum pre-warning	blue
3	Minimum limit stop	brown

Fig. 16: Assignment on the cable

9.2.4 “Metering monitor” terminal

This terminal has no function in the DFXa.

9.2.5 “Tube rupture indicator” terminal

There is an option to connect a tube rupture indicator.

Plug the cable from the tube rupture indicator into the “Tube rupture indicator” terminal.

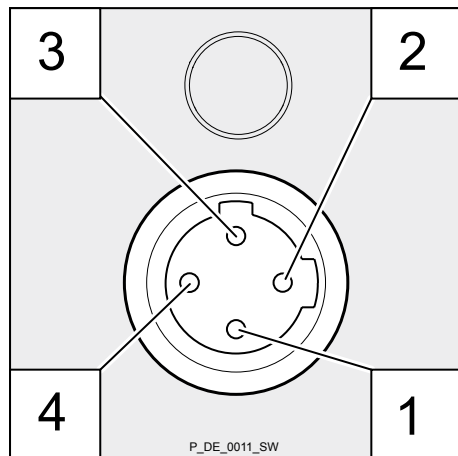

Fig. 17: Assignment on the pump

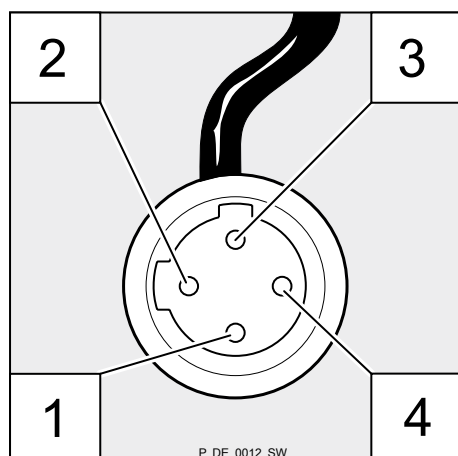

Fig. 18: Assignment on the cable

Electrical interface

Specification	Value
Supply voltage, approx.:	+5 V, can be loaded to 20 mA (current limitation 150 mA)
Power consumption:	min. 10 mA, max. 20 mA (sensor presence detection)
Sensor signal:	potential-free contact (load: 0.5 mA at +5 V) or semiconductor switch (residual voltage < 0.3 V)

Pin	Function	4-wire cable
1	Power supply (5 V)	brown
2	not assigned	white
3	Sensor signal	blue
4	Earth GND	black

9.2.6 Relays

9.2.6.1 Relay functions

Tab. 4: DULCO flex Control - DFXa DFXa

Identity code	Designation	Type	Maximum voltage	Maximum current
0	no relay	-	-	-
1	Fault indicating relay	Changeover contact	230 V AC	6 A
4	Fault indicating relay + Pacing relay	Releasing (NC)	24 V DC	1 A
		Energizing (NO)	24 V DC	100 mA
C	Fault indicating relay + 4-20 mA output	Releasing (NC)	24 V DC	100 mA

Tab. 5: Relay type switches in the event of...

Relay type*	Level warning	Level low	Processor fault
Fault indicating relay:	X	X	X
Warning relay:	X	-	-

* Can be reprogrammed in the 'Relay' menu.

9.2.6.2 "Fault indicating relay" output (identity code 1)

A fault indicating relay can be ordered as an option - refer to the ordering information in the appendix. It is used to emit a signal when there is a fault with the pump and for the "Liquid level low, 1st stage" warning message and the "Liquid level low 2nd stage" fault message.

The fault indicating relay can be retrofitted and is operational once attached to the relay board - refer to the "Retrofitting relays" supplementary operating instructions.

The behaviour is factory-programmed. If another switching function is wished, the pump can be reprogrammed in the 'Relay' menu.

The relay can be retrofitted and is operational once it has been plugged into the relay board.

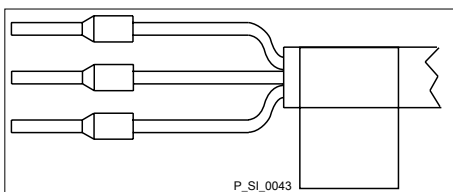

Fig. 19: Assignment on the cable

Electrical interface

Data	Value	Unit
Maximum contact load at 230 V and 50/60 Hz:	8	A
Minimum mechanical service life:	200,000	switching operations

Identity code 1

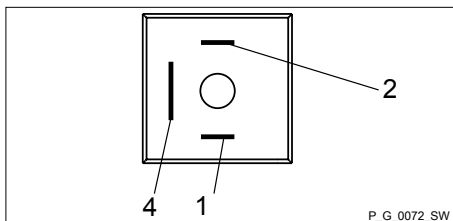

Fig. 20: Assignment on the pump

To pin	VDE cable	Contact	CSA cable
1	white	NO (normally open)	white
2	green	NC (normally closed)	red
4	brown	C (common)	black

9.2.6.3 Output for other relays (identity code 4)

A fault indicating and a pacing relay can be ordered as options - refer to the ordering information in the appendix. The pacing output is electrically isolated by means of an optocoupler with a semiconductor switch. The second switch is a relay (also electrically isolated).

The behaviour is factory-programmed. If another switching function is wished, the pump can be reprogrammed in the 'Relay' menu.

The fault indicating/pacing relay can be retrofitted and is operational once attached to the relay board - refer to the "Retrofitting relays" supplementary instructions.

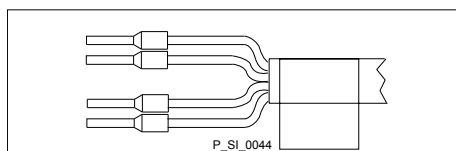

Fig. 21: Assignment on the cable

Electrical interface

for fault indicating relay output:

Data	Value	Unit
Maximum contact load at 24 V and 50/60 Hz:	2	A
Minimum mechanical service life:	20,000,000	switching operations

for semiconductor switch pacing relay:

Data	Value	Unit
Max. residual voltage at $I_{off\ max} = 1\ \mu A$	0.4	V
Maximum current	100	mA
Maximum voltage	24	V DC
Pacing pulse duration, approx.	100	ms

Identify code 4

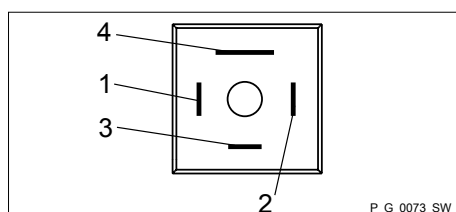

Fig. 22: Assignment on the pump

To pin	VDE cable	Contact	Relay
1	yellow	NO (normally open)	other relay
4	green	C (common)	other relay
3	white	NO (normally open)	Pacing relay
2	brown	C (common)	Pacing relay

9.2.6.4 “Current output plus relay” output (identity code C)

A relay combined with a current output can be ordered as an option. The relay either switches as a fault indicating relay in the event of a fault on the pump and with “Liquid level low 1st stage” warning messages and the “Liquid level low 2nd stage” fault message or is used as a pacing relay.

The behaviour is factory-programmed. If another switching function is wished, the pump can be reprogrammed in the ‘Relay’ menu.

The variable to be signalled for the current output can be selected in the ‘ANALOG OUTPUT’ menu.

The current output plus relay can be retrofitted and operates once it is plugged into the board.

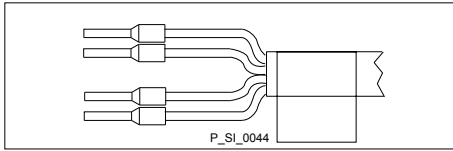

Fig. 23: Assignment on the cable

Electrical interface
for current output

Data	Value	Unit
Open circuit voltage:	8	V
Current range:	4 ... 20	mA
Ripple, max.:	80	µA ss
Load, max.:	250	Ω

for semiconductor switch ("relay"):

Data	Value	Unit
Max. residual voltage at $I_{off\ max} = 1\ \mu A$	0.4	V
Maximum current	100	mA
Maximum voltage	24	V DC
Pacing pulse duration, approx.	100	ms

Identity code c

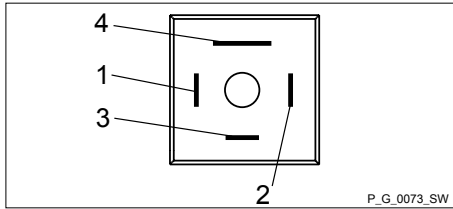

Fig. 24: Assignment on the pump

To pin	VDE cable	Contact	Relay
1	yellow	"+"	Current output
4	green	"-"	Current output
3	white	N/C (normally closed) or NO (normally open)	Relay
2	brown	C (common)	Relay

10 Basic set-up principles



- Please also refer to all the overviews covering "Operating/set-up overview" and "Operating menu for DULCO flex Control - DFXa, complete" in the appendix and the "Overview of equipment and control elements" and "Control elements" chapters.
- The pump exits the menu and returns to a continuous display if [Menu] is pressed or no key is pressed for 60 seconds.

10.1 Basic principles for setting up the control



Fig. 25: Please read

Fig. 26 shows using the "Language" example how to set up something - in turn:

- Sequence of displays
- The path derived from this
- The path as presented in the operating instructions

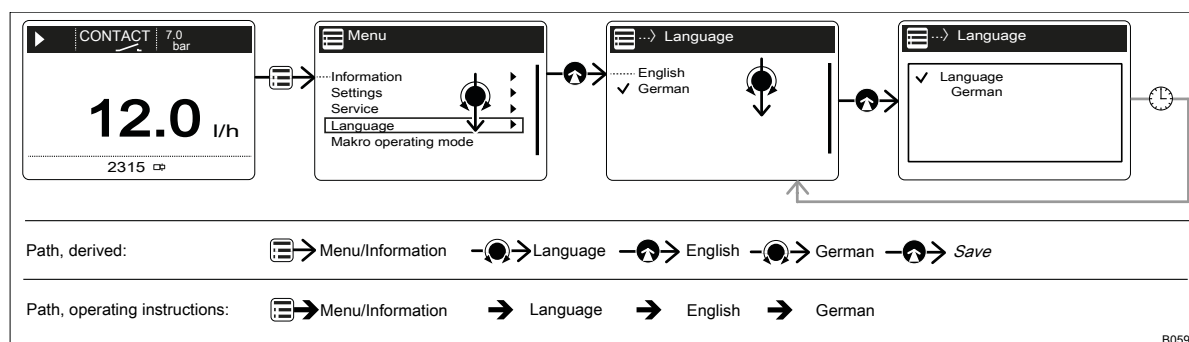

Fig. 26: "Setting up the language": As an example of set-up and path displays

Tab. 6: Legend:

Symbol	Explanation
	Press [Menu]
	Turn the [Clickwheel]
	Press the [Clickwheel]

"Setting up the language" in detail

- To access the 'Menu': press the [Menu] key.
 - ⇒ The cursor immediately points to 'Information'.
- To switch from 'Information' to 'Language': turn the [Clickwheel].
- To return to the 'Language' menu: press the [Clickwheel].
 - ⇒ The cursor points to a language.
- To switch to 'Deutsch': turn the [Clickwheel].
- To save: press the [Clickwheel].
 - ⇒ The software shows a display by way of confirmation.
 - After 2 seconds, it returns to the higher-level 'Menu'.
- To complete the setting: press [Menu].
 - Alternatively: wait 60 seconds or exit the 'Menu' via the [Menu] key or using 'End'.

Confirming an entry

- ➔ Briefly press the *[Clickwheel]*.
- ⇒ The software switches to the next menu point or back to the menu and saves the entry.

Exiting a menu option without confirming it

- ➔ Press *[Back]*.
- ⇒ The software switches to the next menu point or back to the menu without saving anything.

Returning to a continuous display

- ➔ Press *[Menu]*.
- ⇒ The software cancels the entry and switches to a continuous display without saving anything.

Changing adjustable variables

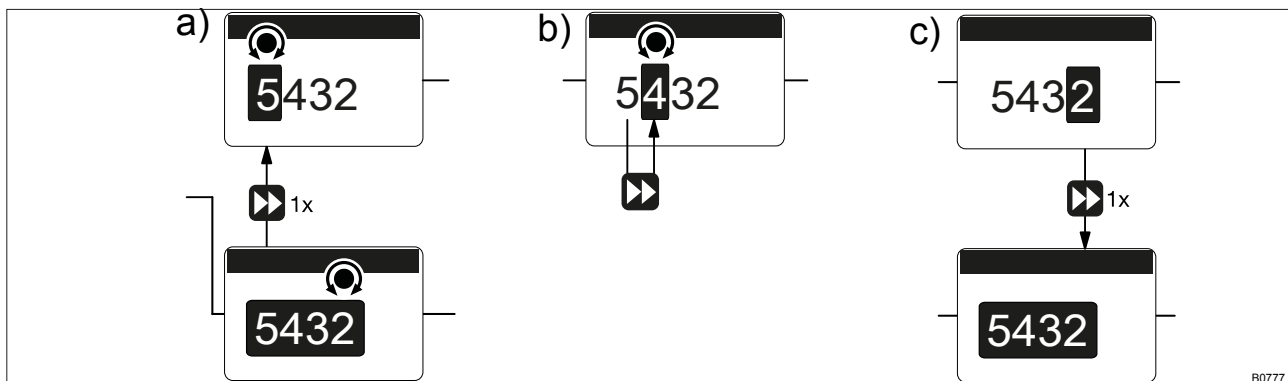

Fig. 27: a) Changing from one figure to its initial figures; b) Changing the figure; c) Returning from the last figure to the (complete) figure (to correct a wrong figure, for example).

Changing a (complete) number

- ➔ Turn the *[Clickwheel]*.
- ⇒ The value of the figure highlighted is raised or lowered.

Changing figures

1. ➔ To adjust the value of a figure digit-by-digit, press *[Priming]*.
⇒ The first figure is highlighted - see Figure above, point a)
2. ➔ To adjust the value of a figure, turn the *[Clickwheel]*.
3. ➔ To move to the next figure, press *[Priming]* - see above Figure, point b).
4. ➔ To run through the figures again, if necessary (possibly because of an incorrect figure), when you get to the last figure press *[Priming]* again - see above Figure, point c).
⇒ Now you can start from the beginning again.

Confirming adjustable variables

- ➔ Press the *[Clickwheel]* 1x.
- ⇒ The software saves the entry.

10.2 Checking adjustable variables

Continuous displays

Before adjusting the pump, you can check the current settings of the adjustable variables:

- ➔ Simply turn the *[Clickwheel]* if the pump is showing a continuous display.
- ⇒ Each time the *[Clickwheel]* engages when you turn it, you will see a different continuous display.



The number of continuous displays depends on the identity code, the selected operating mode and the connected additional devices – see overview of "Continuous displays" in the appendix.

Secondary displays

The lowest line of a continuous display shows different information (which cannot be adjusted in the secondary display) - see "Continuous displays and secondary displays" overview in the appendix.

You can access secondary displays via any continuous display as follows:

1. ➔ Press the *[Clickwheel]* for 3 seconds.
 - ⇒ A frame appears around the secondary display.
2. ➔ Providing there is a frame, you will see a different secondary display each time the *[Clickwheel]* engages when turned.

When you reach the secondary display you wish, leave the *[Clickwheel]* and wait briefly.

10.3 Changing to Setting mode

In a continuous display, if you press  'Menu', the pump in Setting mode changes to 'Menu'. For more information refer to the following chapter entitled "Set up / Menu".

If under 'Access protect.' only 'Menu' or 'All' has been set up (top right  lock symbol), then after pressing the *[Clickwheel]*, first enter the 'Password'.

11 Initial commissioning

User qualification: technical personnel and service - see  'Qualification of personnel' on page 14



WARNING!

The rotating rotor may catch and trap body parts.

- Only use the pump tube in the dosing head as outlined in the instructions provided below.

The user should only now install the pump tube supplied and the other half of the rotor - this will extend the storage service life of the pump tube.

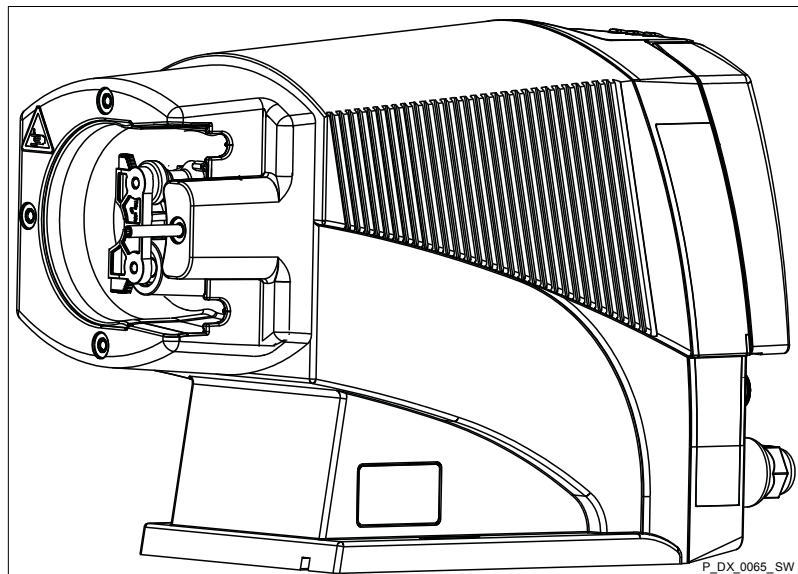





Fig. 28: Starting state of the rotor (bearing cover not shown)

1.  If still necessary: Press  [STOP/START] to bring the pump to a stop (manually).
2.  Go to the  → 'Tube Service' menu - used here to fit the tube.
 - ⇒ 'Go to change position?' appears.



WARNING!

The rotating rotor may catch and trap body parts.

- Only remove the bearing cover once the pump prompts you to do so.
- Refit the bearing cover once prompted to do so by the operating instructions.

3.  Confirm the prompt with 'Yes'.
 - ⇒ The rotor turns slowly and the following appears:
'Please wait...'
 - The rotor stops and 'Please remove cover and take out the Rotor!' appears.

4. ➤

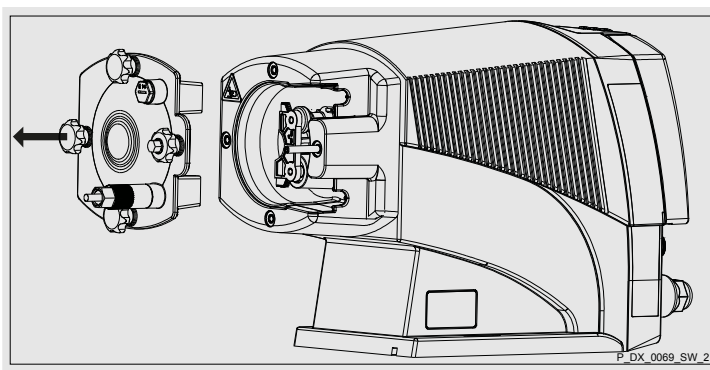

Loosen the 4 star-shaped screws on the dosing head and remove with the bearing cover.

5. ➤ Thoroughly grease the pump tube and the running surface with the silicone grease provided.

6. ➤ Insert the pump tube into the dosing head.

7. ➤

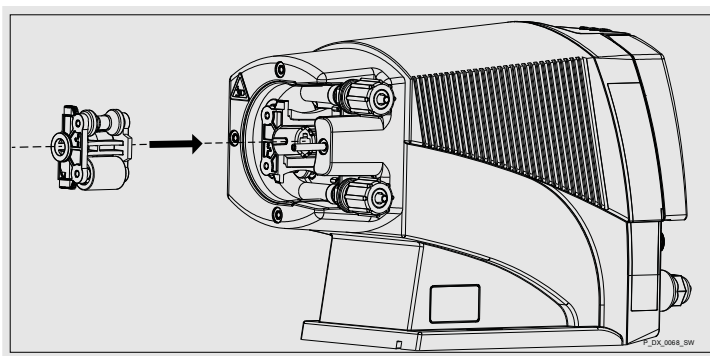

Insert the rotor half supplied.

8. ➤

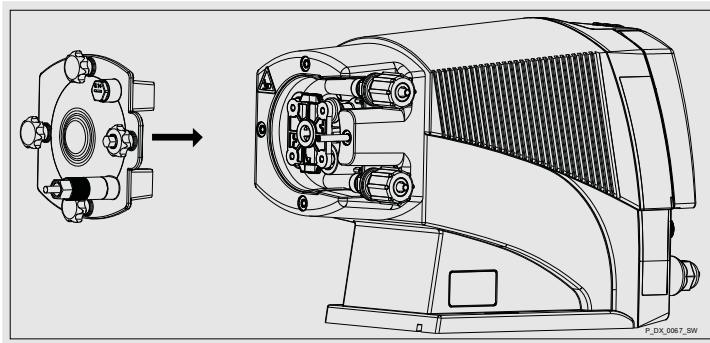

If the surfaces of the two rotor halves are perfectly flush, place the bearing cover onto the dosing head.

9. ➤ Initially only loosely screw all 4 star-shaped screws into the dosing head.

10. ➤ Manually tighten the 4 star-shaped screws. Screw the domed nut onto the 4th star-shaped screw again and tighten it to provide a locking function.

11. ➤ Press the Clickwheel.

⇒ The rotor turns slowly and the following appears:

'Please wait...'

The rotor stops and *'Please change the tube!'* appears. Please ignore this.

- 12.** ▶ Press the Clickwheel
- ⇒ The rotor turns slowly and the following appears:
'Please wait!'
The rotor stops and *'Insert rotor again!'* appears. Please ignore this.
- 13.** ▶ Press the Clickwheel.
- ⇒ The rotor turns and the following appears:
'Please wait...'
The rotor stops - this time standing on its tip - and *'Install Cover again!'* appears. Please ignore this.
- 14.** ▶ Press the Clickwheel.
- ⇒ *'Run in tube?'* appears.
'Yes' / 'No'
- 15.** ▶ Selecting *'No'* exits this macro.
The pump retracts the pump tube (4) if *'Yes'* is selected.
- ⇒ *'Run in tube...'* appears.
The rotor turns slowly a couple of times.
- 16.** ▶ The *'Tube change interval'* menu appears.
In the first *'Revolutions'* menu item, you have the option of extending or shortening the warning time for the next tube service. You can do this by changing the *'Revolutions'* - also refer to *'Service → Tube'*.
- 17.** ▶ Press the *[Clickwheel]* to reset the warning time.
- ⇒ *'Reset interval now!'* appears.
- 18.** ▶ Press the *[Clickwheel]* again to complete the tube change.
- ⇒ *'Complete!'* and a hand symbol appear. This is a reminder that the pump still needs to be stopped manually. If necessary, now restart the pump using the  *[STOP/START]* key.

12 Set up / 'Menu'

User qualification: technical personnel and service - see  'Qualification of personnel' on page 14



- Refer to the overviews covering "Operating/set up overview" and "Operating menu DULCO flex Control - DFXa, complete" in the appendix and in the "Overview of equipment" - "Control elements" chapters by way of supplementary information.
- The pump exits the menu and returns to a continuous display if  [Menu] is pressed or if no key is pressed for 60 seconds.

The 'Menu' is sub-divided as follows:

- 1 - 'Information'
- 2 - 'Settings'
- 3 - 'Tube service'
- 4 - 'Timer'
- 5 - 'Service'
- 6 - 'Language'

12.1 'Information'

 → 'Menu / Information → ...'

The 'Information' menu provides information on your pump and certain parameters and counters. The number and type can depend on the pump settings.

12.2 'Settings'

 → 'Menu / Information → Settings → ...'

The 'Settings' menu generally includes these setting menus:

- 1 - 'Operating mode'
- 2 - 'Dosing direction'
- 3 - 'Concentration'
- 4 - 'Calibrate'
- 5 - 'System'
- 6 - 'Inputs/outputs'
- 7 - 'Config-I/Os'
- 8 - 'Priming time'
- 9 - 'Set time'
- 10 - 'Date'

12.2.1 'Operating mode'

 → 'Menu / Information → Settings → Operating mode → ...'

12.2.1.1 'Manual'

 → 'Menu / Information → Settings → Operating mode → Manual'

'Manual' operating mode allows you to operate the pump manually.

The capacity can be set in the continuous displays of this operating mode.

12.2.1.2 'Contact'

 → 'Menu / Information → Settings → Operating mode → Contact → ...'

The 'Contact' operating mode enables you to meter metering volumes, which you can preset.

You can trigger metering via a pulse sent via the "External control" terminal.

The purpose of this operating mode is to convert the incoming pulses into a metering volume, which you can preset.



CAUTION!

The pump maintains the capacity when changing over from 'Manual' operating mode to 'Contact' operating mode.



The maximum capacity can be set in 'Contact' operating mode.

Memory - Pulses not yet processed

You can also activate the 'Memory' function extension ("memory" identifier). When 'Memory' is activated, the pump adds up the remaining volume, which could not be processed, up to the maximum capacity of the memory of 99,999 l. If this maximum capacity is exceeded, the pump goes into fault mode.



CAUTION!

- Only with 'Memory' - 'off': If you press  [STOP/START] or empty the contact memory ('Menu / Information → Service → Clear counters') or the "Pause" function is activated, the 'Memory' is cleared.

Contact water meter

Using "Pulse control" you can ideally adapt the pump to the relevant process, for example in conjunction with contact water meters.

12.2.1.3 'Batch'

 → 'Menu / Information → Settings → Operating mode → Batch → ...'

The 'Batch' operating mode enables you to pre-select large metering volumes or metering times.

You can trigger the metering volume using the [Clickwheel] if you have already switched to the 'Push' continuous display. You can also trigger them via a pulse using the "External control" terminal.

Memory - remaining volume not yet processed

You can also activate the 'Memory' function extension ("memory" identifier). When 'Memory' is activated, the pump adds up the remaining volume, which could not be processed, up to the maximum capacity of the memory of 99,999 l. If this maximum capacity is exceeded, the pump goes into fault mode.



CAUTION!

- The pump maintains the capacity when changing over from 'Manual' operating mode to 'Batch' operating mode.
- When you press  [STOP/START] or the "Pause" function is activated, the 'Memory' is cleared.



In operation, the batch size can be changed more easily by using the "Batch size" continuous display.

12.2.1.4 'Analog' (option)

 → 'Menu / Information → Settings → Operating mode → Analog → ...'

The secondary display "Signal current" indicates the incoming current.

You can select 5 types of current signal processing:

- '0 - 20 mA'
- '4 - 20 mA'
- 'Linear curve'
- 'Lower side band'
- 'Upper side band'

'0 - 20 mA'

At 0 mA the pump is stationary –

At 20 mA the pump works at maximum speed.

'4 - 20 mA'

At 4 mA the pump is stationary –

At 20 mA the pump works at maximum speed.

With current signals of less than 3.8 mA, an error message appears and the pump stops (e.g. if a cable has broken).

'Linear curve'

The "Linear curve" symbol appears on the LCD screen. You can enter any speed behaviour proportional to the current signal. For this purpose, enter any two points P1 (I1, F1) and P2 (I2, F2) (F1 is the speed at which the pump is to operate at current I1, F2 is the speed at which the pump is to operate at current I2...); this defines a straight line and thus the behaviour is specified:

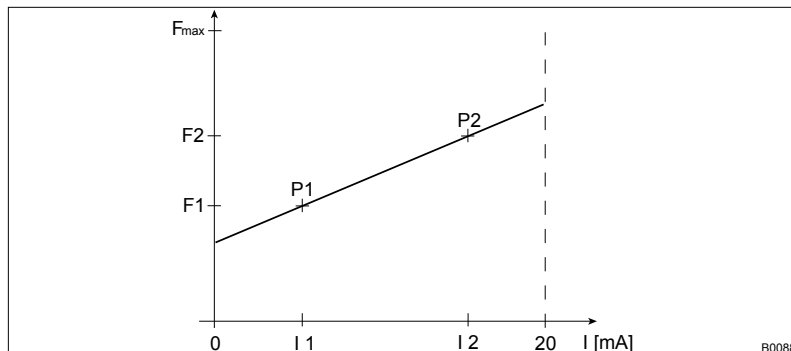

Fig. 29: Speed-current diagram for "Linear curve"



Plot a diagram similar to the one above – with values for $(I1, F1)$ and $(I2, F2)$ – so that you can set the pump as desired!



The smallest processable difference between $I1$ and $I2$ is 4 mA ($\| I1 - I2 \| \geq 4$ mA).

Error processing

In the 'Error message' menu item, you can activate error processing for these types of processing.

'Lower side band'

Using this type of processing, you can control a metering pump using the current signal as shown in the diagram below.

However, you can also control two metering pumps for different feed chemicals via a current signal (e.g. one acid pump and one alkali pump using the signal of a pH sensor). To do this, connect the pumps electrically in series.

Error processing

In the 'Error message' menu item, you can activate error processing for these types of processing.

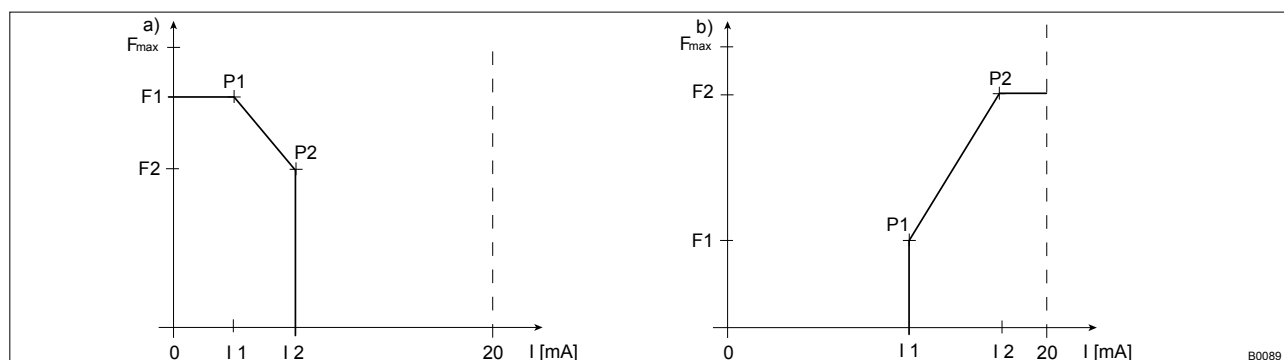

Fig. 30: Speed-current diagram for a) Lower side band, b) Upper side band

'Upper side band'

Using this processing type, you can control a metering pump using the current signal as shown in the diagram above.

Everything functions according to the 'Lower side band' type of the processing.

12.2.2 Dosing direction

 → 'Menu / Information → Settings → Dosing direction'

The 'Dosing direction' menu enables you to select the pump's dosing direction:





- clockwise
- anti-clockwise

12.2.3 Concentration

 → 'Menu / Information → Settings → Concentration → ...'

The desired mass concentration of feed chemical that will subsequently be required in the dissolving medium (e.g. the main flow) can be entered directly in the "Concentration" continuous display.

The principle of entering the concentration:

1.  Select the operating mode.
2.  Go to 'Set up'- 'Concentration'- 'Concentration control' and set to 'Active'.
3.  Then set the data required for the feed chemical and dissolving medium.
4.  Set the desired concentration in the "Concentration" continuous display.



- The "Concentration" continuous display only appears, if:
 - the pump is calibrated.
 - the 'Concentration' menu was run through in the operating mode used.
 - and 'Concentration control' was switched to 'active' - in the operating mode being used.
- The "Concentration" continuous display switches to the "%" display mode at concentrations above 999.99 ppm.
- When changing between operating modes, the pump saves the settings for each operating mode - provided it is connected to supply voltage.
- If the pump is to display the concentration as a volume concentration, enter "1.00" kg/l for the density of the feed chemical.

12.2.3.1 'Manual' operating mode (settings for the 'Concentration' function)

 → 'Menu / Information → Settings → Concentration → Concentration control → Flow of main medium → ...'

The "Concentration input" in 'Manual' operating mode is intended for metering a substance into pipework containing a medium flowing at a constant rate ('main flow') in such a way that it has a specific mass concentration in the flow.

**CAUTION!****Danger of concentrations being too high**

The metering pump can continue to meter if the flow falls or stops entirely.

- Take system-based precautions to prevent the metering pump from continuing to meter in these circumstances.

The prerequisites are that:

- the flowing medium has the same density as water ($1 \text{ kg/l} \hat{=} \text{g/cm}^3$)
- the mass concentration of the feed chemical is known - see the feed chemical safety data sheet (e.g. with 35% sulfuric acid: 35 %)
- the density of the feed chemical is known - see the feed chemical safety data sheet (e.g. with 35% sulfuric acid: $1.26 \text{ kg/l} \hat{=} \text{g/cm}^3$)
- The measurement unit for the liquid volume is set in the 'System' → 'Volume unit' menu.

Procedure**CAUTION!**

The precision of the concentration is strongly dependent on:

- the precision of the metering pump calibration.
- the precision of the inputs.

1. ➤ Calibrate the metering pump if it is not yet calibrated - see chapter 'Set up' - 'Calibration' chapter.
2. ➤ Select 'Manual' - 'Operating mode' (settings potentially configured in other operating modes remain saved).
3. ➤ Select 'Concentration' in the 'Set up' menu.
4. ➤ Set 'active' in the 'Concentration control' menu item and press the [Clickwheel].
5. ➤ Set the 'Main medium flow' (in the pipework) and then press the [Clickwheel].
6. ➤ Set the 'Feed chemical mass concentration' and press the [Clickwheel].
7. ➤ Set the (mass) 'Feed chemical density' and press the [Clickwheel].
⇒ The 'Concentration' menu appears.
8. ➤ Press [Menu] [≡].
⇒ A continuous display appears.
9. ➤ Turn the [Clickwheel] to go to the "Concentration" continuous display (ppm or %).
10. ➤ Enter the required mass concentration of feed chemical in the main flow by pressing and turning the [Clickwheel].

Tab. 7: Possible values of adjustable variables

Adjustable variable	Lower value	Upper value	Increment
Flow in m ³ /h	0000.1	9999.9	0000.1
Mass concentration in %	000.01	100.00	000.01
Mass density in kg/l	0.50	2.00	0.01

12.2.3.2 'Contact' operating mode (settings for 'Concentration' function)

 → 'Menu / Information' → Settings → Concentration
→ Concentration control → Contact distance → ...'

The "Concentration input" in 'CONTACT' operating mode is intended for metering a substance into pipework containing a medium flowing at a variable rate in such a way that there is a specific mass concentration in the flow.

**CAUTION!****Danger of concentrations being too high**

The metering pump can continue to meter if the flow falls or stops entirely.

- Take system-based precautions to prevent the metering pump from continuing to meter in these circumstances.











The prerequisites are that:

- the flowing medium has the same density as water (1 kg/l $\hat{=}$ g/cm³)
- the mass concentration of the feed chemical is known - see the feed chemical safety data sheet (e.g. with 35% sulfuric acid: 35 %)
- the density of the feed chemical is known - see the feed chemical safety data sheet (e.g. with 35% sulfuric acid: 1.26 kg/l $\hat{=}$ g/cm³)
- a contact water meter is hydraulically installed and connected to the external input of the metering pump.
- The measurement unit for the liquid volume is set in the 'System → Volume unit' menu.

Procedure**CAUTION!**

The precision of the concentration is strongly dependent on:

- the precision of the metering pump calibration.
- the precision of the inputs.

1.  Calibrate the metering pump if it is not yet calibrated - see chapter 'Set up' - 'Calibration' chapter.
2.  Select 'Contact' - 'Operating mode' and simply confirm the associated menu items with the [Clickwheel] (settings potentially configured in other operating modes remain saved).
3.  Select 'Concentration' in the 'Set up' menu.
4.  Set 'active' in the 'Concentration control' menu item and press the [Clickwheel].
5.  Set the 'Contact distance' and press the [Clickwheel].
6.  Set the (mass) 'Feed chemical concentration' and press the [Clickwheel].
7.  Set the (mass) 'Density dosing medium' and press the [Clickwheel].
⇒ The 'Concentration' menu appears.
8.  Press [Menu] .
⇒ A continuous display appears.
9.  Turn the [Clickwheel] to go to the "Concentration" continuous display (ppm or %).
10.  You can enter the desired mass concentration using the [Clickwheel].

Tab. 8: Possible values of adjustable variables

Adjustable variable	Lower value	Upper value	Increment
Contact distance in l/contact	000.10	999.99	000.01
Mass concentration in %	000.01	100.00	000.01
Mass density in kg/l	0.50	2.00	0.01

12.2.3.3 'Batch' operating mode (settings for the 'Concentration' function)

☰ → 'Menu / Information' → Settings → Concentration
 → Concentration control → Volume main medium → ...'

The "Concentration input" in 'Batch' operating mode is intended for metering a substance into the medium in a storage tank so that there is then a defined mass concentration in the storage tank (when batching a solution – do not forget to stir!).

The prerequisites are that:

- the medium in the storage tank has the same mass density as water (1 kg/l $\hat{=}$ g/cm³)
- the mass concentration of the feed chemical is known - see the feed chemical safety data sheet (e.g. with 35% sulfuric acid: 35 %)
- the density of the feed chemical is known - see the feed chemical safety data sheet (e.g. with 35% sulfuric acid: 1.26 kg/l $\hat{=}$ g/cm³)
- The measurement unit for the liquid volume is set in the 'System → Volume unit' menu.

Procedure



CAUTION!

The precision of the concentration is strongly dependent on:

- the precision of the metering pump calibration.
- the precision of the inputs.

1. → Calibrate the metering pump if it is not yet calibrated - see 'Set up' - 'Calibration' chapter.
2. → Select 'Batch' - 'Operating mode' and simply confirm the associated menu items with the [Clickwheel] (settings potentially configured in other operating modes remain saved).
3. → Select 'Concentration' in the 'Set up' menu.
4. → Set 'active' in the 'Concentration control' menu item and press the [Clickwheel].
5. → Set the 'Volume main medium' of the medium in the storage tank and press the [Clickwheel].
6. → Set the (mass) 'Feed chemical concentration' and press the [Clickwheel].
7. → Set the (mass) 'Feed chemical density' and press the [Clickwheel].
 ⇨ The 'Concentration' menu appears.
8. → Press [Menu] ☰.
 ⇨ A continuous display appears.
9. → Turn the [Clickwheel] to go to the "Concentration" continuous display (ppm or %).
10. → You can enter the desired mass concentration using the [Clickwheel].

Tab. 9: Possible values of adjustable variables

Adjustable variable	Lower value	Upper value	Increment
Volume in l	0000.1	9999.9	0000.1
Mass concentration in %	000.01	100.00	000.01
Mass density in kg/l	0.50	2.00	0.01

12.2.3.4 'Analog' operating mode (settings for the 'Concentration' function)

☰ → 'Menu / Information' → Settings → Concentration
 → Concentration control → Max.throughput main medium → ...'

The "Concentration input" in 'Analog' operating mode is intended for metering a substance into pipework containing a medium flowing at a variable rate in such a way that there is a specific mass concentration in the flow.



CAUTION!

Danger of concentrations being too high

The metering pump can continue to meter if the flow falls or stops entirely.

- Take system-based precautions to prevent the metering pump from continuing to meter in these circumstances.



CAUTION!

Risk of incorrect concentrations

- After adjusting, check whether the concentrations at various flows correspond to the desired result.

The prerequisites are that:

- the flowing medium has the same density as water ($1 \text{ kg/l} \triangleq \text{g/cm}^3$)
- the mass concentration of the feed chemical is known - see the feed chemical safety data sheet (e.g. with 35% sulfuric acid: 35 %)
- the density of the feed chemical is known - see the feed chemical safety data sheet (e.g. with 35% sulfuric acid: $1.26 \text{ kg/l} \triangleq \text{g/cm}^3$)
- a flow meter with analogue output is hydraulically installed and connected to the external input of the metering pump.
- The measurement unit for the liquid volume is set in the 'System' → 'Volume unit' menu.

Procedure



CAUTION!

The precision of the concentration is strongly dependent on:

- the precision of the metering pump calibration.
- the precision of the inputs.

1. → Calibrate the metering pump if it is not yet calibrated - see chapter 'Set up' - 'Calibration' chapter.
2. → Check whether the metering pump is set to 'Automatic' - 'on' metering mode.
3. → Select 'Analog' operating mode and confirm with the [Clickwheel].
4. → Set '0...20 mA' or '4...20 mA' in the 'Select analog' menu item and press the [Clickwheel].

5. ▶ Select 'Concentration' in the 'Set up' menu.
6. ▶ Set 'active' in the 'Concentration control' menu item and press the [Clickwheel].
7. ▶ Set the 'Max.throughput main medium' (in the pipework) and press the [Clickwheel]. (It is then assigned to the current value of 20 mA.)
8. ▶ Set the (mass) 'Feed chemical concentration' and press the [Clickwheel].
9. ▶ Set the (mass) 'Feed chemical density' and press the [Clickwheel].
⇒ The 'Concentration' menu appears.
10. ▶ Press [Menu] .
⇒ A continuous display appears.
11. ▶ Turn the [Clickwheel] to go to the "Concentration" continuous display (ppm or %).
12. ▶ You can enter the desired mass concentration using the [Clickwheel].



CAUTION!

- Note the decimal point.
- The mass concentration is affected by changes to the capacity.
- The pump limits the upper value for the mass concentration, because otherwise the incremental jumps when adjusting would be unacceptably large.



The least significant figures of the value in the continuous display cannot be changed at will using the [Arrow keys], rather only in incremental jumps resulting from the input data.

If necessary, change the capacity and adjust the concentration; as you do this, the pump compensates via the speed.

Tab. 10: Possible values of adjustable variables

Adjustable variable	Lower value	Upper value	Increment
Max. flow in m ³ /h	0000.1	9999.9	0000.1
Mass concentration in %	000.01	100.00	000.01
Mass density in kg/l	0.50	2.00	0.01

12.2.4 Calibration

 → 'Menu / Information → Settings → Calibrate → ...'



Accuracy of calibration

Normally the pump does not have to be calibrated.

However, the pump can be calibrated if viscous feed chemicals are used or if extremely high accuracy is required.

There are 2 options for calibrating the pump:

- 1 - Calibrate using 'Calibr. factor'
- 2 - 'Calibrate' using a calibration procedure

12.2.4.1 Calibrate using calibr. factor

If you already know what calibration factor is needed for the pump to achieve the desired accuracy, go to 'Calibrate'- 'Calibr. factor' and enter the appropriate calibration factor as a %.

12.2.4.2 Calibrating using a calibration procedure

If you do not know which calibration factor you need, use this calibration procedure.



WARNING!

If the feed chemical is hazardous, take appropriate safety precautions when performing the following calibration instructions. Observe the material safety data sheet for the feed chemical!



Please only calibrate using the suction hose – as shown here.

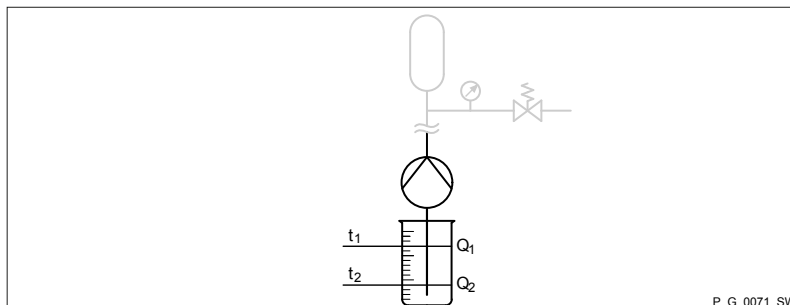

P_G_0071_SW

Preparation

1. Use the [Clickwheel] to scroll through the continuous displays to check whether litres or gallons have been selected.
2. If the incorrect volume unit has been selected, correct it in the 'Menu / Information → Settings → System → Volume unit' menu.
3. Check whether the capacity in the continuous display is not too low for calibration.
4. Lead the suction hose into a measuring cylinder containing the feed chemical – make sure that the pressure tube is permanently installed (operating pressure, ...!).
5. Prime the feed chemical (press [▶] [Priming]) if the suction hose is empty.

Calibration procedure

1. Record the level in the measuring cylinder.
2. Enter 'Manual' operating mode in the 'Menu / Information → Settings → Operating mode' menu, and ensure that the pump is stopped using the [STOP/START] key.
3. Select the 'Menu / Information → Settings → Calibrate' menu and press the [Clickwheel].
 - ⇒ The 'Start calibration' (PUSH) menu item appears.

4. ▶ To start calibration, press the [Clickwheel].
 - ⇒ The 'Calibrate ...' menu item appears, the pump starts to pump and indicates the number of revolutions.
5. ▶ After a reasonable number of revolutions (a minimum of 200), use the [Clickwheel] to stop the pump.
 - ⇒ The 'Calibrate ended' menu item appears. It asks you to enter the calibration volume.
6. ▶ Determine the required metering volume (difference between initial volume - remaining volume in the measuring cylinder).
7. ▶ Use the [Clickwheel] to enter this volume in the 'Calibrate ended' menu item and close.
 - ⇒ The pump switches to the 'Calibration result' menu item - the pump is calibrated.
8. ▶ Press the [Clickwheel].
 - ⇒ The pump returns to the 'Menu / Information → Settings' menu.

12.2.5 System

☰ → 'Menu / Information → Settings → System → ...'

The 'System' menu is sub-divided into the following sub-menus:

- 1 - 'Hose type'
- 2 - 'Configure dosing head'
- 3 - 'Volume unit'
- 4 - 'Start behaviour'

12.2.5.1 Hose type

☰ → 'Menu / Information → Settings → System → Hose type → ...'

You need to enter the hose type in the 'Hose type' menu if you have changed the hose type.

The 'Hose type' consists of a hose material, its maximum permitted back pressure, and its maximum pump capacity:

Tab. 11: Examples of hose type

Hose material	maximum permitted back pressure	maximum pump capacity
TVP_	5BAR_	30 l
TVP_	7BAR_	30 l
PUR_	5BAR_	30 l

12.2.5.2 'Configure dosing head'

☰ → 'Menu / Information → Settings → System → Configure dosing head → ...'

In the 'Configure dosing head' menu, you have to set the dosing head's position for if you have turned it

because you can turn the dosing head as follows:

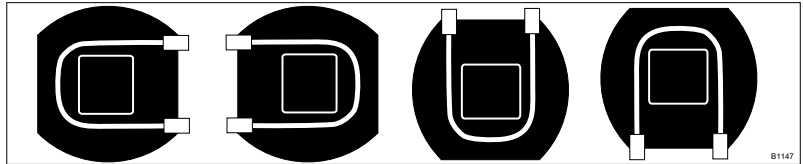
**CAUTION!**

Whenever the dosing head's alignment has been changed, the new alignment must be correctly stated otherwise the 'Tube Service' will no longer work properly.

12.2.5.3 Volume unit



☰ → 'Menu / Information → Settings → System → Volume unit → ...'

You can select another unit for the volume in the 'Volume unit' sub-menu.

12.2.5.4 Start behaviour

☰ → 'Menu / Information → Settings → System → Start behaviour → ...'

You can specify the start behaviour of the pump once the supply voltage has been switched on in the 'Behaviour on start' sub-menu.

Start behaviour	Description
'always STOP'	The pump always wakes up in "Manual stop via the  [STOP/START] key" mode. It can only be started by pressing  [STOP/START].
'always on'	The pump always starts immediately.
'last status'	The pump always adopts the last status it had before the supply voltage was switched off.

12.2.6 Config-I/Os

☰ → 'Menu / Information → Settings → Config-I/Os → ...'

The 'Config-I/Os' menu is used to assign functions to the "Config-I/O" (-) terminal pins.

Input

For the 'Timer': pins can be configured as an input.

For a remote-controlled 'reversal of direction of rotation': you can / must configure 2 pins:

Pin	Setting
1st pin	'closed - clockwise.'
2nd pin	'closed - counter-clockwise'

The result is then:

1st pin + GND	2nd pin + GND	Direction of rotation
closed	open	clockwise
open	closed	counter-clockwise
open	open	Error *
closed	closed	Error *

* 1 second remains for a reversal of direction of rotation without error message.

The manual reversal of direction of rotation is now hidden.

If a 3rd pin is free, you can have the direction of rotation reset - [↪ Further information on page 56.](#)

Output

The pins can be configured as outputs (timer, warning, error, auxiliary, reset direction of rotation, ...).

It is also possible to use 'Selective errors' or 'Selective warning' to issue very specific errors or warnings (diaphragm rupture, defective stroke metering, air in the dosing head, ...).

It is also possible to reset the actual direction of rotation as a signal level using a free pin and 'Reset direction of rotation' depending on the setting:

Setting +	Actual direction of rotation =	signal level
'Direction of rotation Clockwise'	clockwise	0
	counter-clockwise	1
'Direction of rotation counter-clockwise.'	counter-clockwise	0
	clockwise	1

12.2.7 Inputs/outputs

 → 'Menu / Information → Settings → Inputs/outputs → ...'

The 'Inputs/outputs' menu is split into the following sub-menus:

- 1 - 'Auxiliary capacity'
- 2 - 'Relay1' (optional)
- 3 - 'Relay2' (optional)
- 4 - 'mA-Output' (optional)
- 7 - 'Pause input' (optional)
- 6 - 'Niveau monitoring'

12.2.7.1 'Auxiliary capacity'

 → 'Menu / Information → Settings → Inputs/outputs
→ Auxiliary capacity → ...'

The programmable 'Auxiliary capacity' function enables the pump to be switched over to an additional capacity that can be fixed in the 'Auxiliary capacity' menu.

It can be activated via the "External control" terminal. If 'Auxiliary capacity' is being used, then the "AUX" identifier appears on the LCD screen.

Refer to the "Hierarchy of Operating Modes, Functions and Fault Statuses" for the order of the various operating modes, functions and fault statuses.

12.2.7.2 'Relay1 (optional)'

 → 'Menu / Information → Settings → Inputs/outputs → Relay1 → ...'



The setting options for the 'Relay' function are only available if a relay is fitted.

DULCO flex Control, DFXa

Tab. 12: Relay, physical and pre-set to ...

Identity code specification	Relay, physical	Pre-set to ...
1	1 x changeover contact 230 V – 8 A	Fault indicating relay, N/C
4	2 x N/O 24 V – 100 mA	Fault indicating relay, N/C, and pacing relay
C	1 x N/O 24 V – 100 mA, + 4...20 mA output	Fault indicating relay, N/C

Relay type

You can reprogram the relays to these types:

Menu setting	Effect
Timer	The relay is available for the timer.
Fault	The relay switches in the event of a fault message (red LED*).
Warning	The relay switches in the event of a warning message (yellow LED*).
Warning + error	The relay switches in the event of a warning message (yellow LED*) or a fault message (red LED*).
Warning + error + stop	The relay switches in the event of a warning message (yellow LED*) or a fault message (red LED*) or a stop.
Pump active	The relay switches as soon as the pump is in standby and not in a state like 'Pause'.
Speed	The relay switches with every revolutions.
Metering / Batch	The relay changes its state as soon as a metering volume / batch is being processed.

* see the "Troubleshooting" chapter

Relay polarity

You can set here how a relay is to switch.

Menu setting	Effect
normally-closed (NC)	The relay is closed in normal mode and opens with a triggering event.
normally-open (NO)	The relay is open in normal mode and opens with a triggering event.

12.2.7.3 'Relay2 (optional)'

 → 'Menu / Information → Settings → Inputs/outputs → Relay2 → ...'

For more information on 'Relay2' - see [Chapter 12.2.7 'Inputs/outputs' on page 56](#).

12.2.7.4 'mA-Output (optional)'

 → 'Menu / Information → Settings → Inputs/outputs → mA-Output → ...'

You can set which current range is to be used at the mA output here.

You can then set whether, for example, the current dosing rate (litres / hour) is to be signalled at the mA output and set the desired value for 20 mA.

You can also set the state which the mA output is to signal at 23 mA:

- Passive
- Error
- Warning
- Warning + error
- Warning + error + stop

12.2.7.5 'Pause input'

 → 'Settings → Inputs/outputs → Pause → ...'

In the 'Pause' menu, you can select whether the pump switches to 'Pause' with a 'make contact' (NO) or 'break contact' (NC) input contact signal.

12.2.7.6 'Niveau monitoring'

 → 'Settings → Inputs/outputs → Niveau monitoring → ...'

In the 'Niveau monitoring' menu, you can select whether the pump is to run with standard 2-stage level monitoring or a continuous form.

12.2.8 'Priming time'



 → 'Menu / Information → Settings → Priming time → ...'

In the 'Priming time' menu, you can select how long the metering pump is to prime once  [Priming] has been pressed.

12.2.9 'Set time'

 → 'Menu / Information → Settings → Set time → ...'

You can set the time in the 'Set time' menu.

1.  Use the dial to adjust a figure.
2.  Use  [Priming] to move to the next figure.

Under 'Auto. Summertime' you can select whether you wish to change over to 'Summertime'.

You can also state when the pump is to change to and from 'Summertime'.

Check under 'Location' whether the pump is also set to your 'hemisphere' of the world.

12.2.10 'Date'

 → 'Menu / Information → Settings → Date → ...'

You can set the date in the 'Date' menu.

12.3 'Tube service'

 → 'Menu / Information → Service → Tube service → ...'

This menu only appears once a manual stop has been performed using the  [STOP/START] key.

This lets you replace a tube following the guidance provided. For the detailed description - see  Chapter 15.1 'Replacing the pump hose' on page 76

12.4 Timer

 → 'Menu / Information → Timer → ...'



– Please first read this chapter completely to gain an overview. You will then understand the timer better when working through the chapter.

The timer DULCO flex Control - DFXa can do the following at predefined times and intervals or event-dependent:

- open / close the relays
- switch the level of a Config I/O output
- be triggered by the level at a Config I/O input
- start a delayer
- switch operating mode
- allow the pump to work at a defined capacity

- stop / start the pump
- trigger a batch ('Batch (time)')

12.4.1 Activation / deactivation

☰ → 'Menu / Information → Timer → Activation → ...'



You can only program the timer when 'Activation' is set to 'inactive'.

- ➔ To program the timer, set 'Activation' to 'inactive'.
 - ⇒ The first line of the timer menu 'Timer state' then shows 'Inactive'.

- ➔ To activate the timer, set 'Activation' to 'active'.
 - ⇒ The first line of the timer menu 'Timer state' then displays 'active'.

The timer starts working - the timer identifier ⌚ is visible in the continuous display.



When 'Activation' is set to 'active', the timer software generates the status of the pump which the pump would have precisely had at this time if it had been set to 'active' without any interruption.

Delayed, linked actions are unaffected by this.

12.4.2 Setting the timer

☰ → 'Menu / Information → Timer → Set Timer → ...'

You can create commands (also known as "program lines") for a timer program in the 'Set Timer' menu.

You can create up to 99 commands (program lines).

Create the command as follows:

- 1 - Create a 'new' command (program line)
- 2 - Select the 'Triggering event' (trigger) and the time and/or interval if necessary
- 3 - Select 'Action' and a value, if necessary
- 4 - Check the command
- 5 - Create the next command – if necessary

The following administration functions are available to manage the commands (program lines):

- 1 - Reprogram program line ('New')
- 2 - Check program line ('Show')
- 3 - Change program line ('Change')
- 4 - Clear individual program line ('Clear')
- (5 - Clear the entire program ('Clear all' one level higher))

**CAUTION!**

The pump does not perform any plausibility check.

Please ensure before using that the timer actually does what you expect of it. Please consider the consequences for your system.

**CAUTION!**

If you wish to use automatic summer time adjustment ('Settings' - 'Time') avoid any triggering events between 02:00 a.m. and 03:00 a.m.

**Restriction with day numbers**

If you wish to start an action on a certain day of each month, note that the timer only permits days 01 - 28.

**Using Config I/Os**

If you wish to use Config I/Os as inputs or outputs, you first need to configure them as a 'Timer input' or 'Timer output' under 'Menu / Information → Settings → Config I/Os → ...'.

12.4.2.1 Reprogramming program line ('new')

**CAUTION!**

If the 'Timer state' is set to 'active', the pump can neither be set nor programmed!

To do so, set the 'Timer state' under 'Activation' to 'inactive'.

12.4.2.1.1 Principle construction of a program line

In principle, an (imaginary) program line / instruction is set up as follows:

Time event (trigger)		Action	
Workdays 1 (Mo-Fr)	Time of day 12:00	Manual	20.00 l/h

This corresponds to the following instruction:

WHEN triggering event, THEN action

The **time event (trigger)** defines what action or at what time an action is to take place.

The **action** defines which type of action is to take place.

The finished program line/ instruction looks like this:

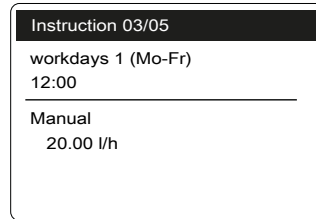

B1106

Example

Time event (trigger)		Action	
Workdays 1 (Mo-Fr)	Time of day 12:00	Manual	20.00 l/h

The example means:

When it is 12:00 on a workday, then the pump is to work in 'Manual' operating mode at 20.00 l/h.

Tab. 13: Time events (triggers)

Time events (triggers)	Description	Remark
Time	Switching time reached	For more information - see Chapter 12.4.2.1.3 'Selecting cyclic time events and switching point' on page 63
'Init'	Thus declared is started at the beginning of the program process	Defines starting conditions - see Chapter 12.4.2.1.2 'Init' Initial conditions' on page 63

You can select an action and also a value:

Tab. 14: Action

Action	Description	Value
'Manual'	Switch over in this operating mode	Litre/h ('Dos. capacity')
'Halt'	Stop pump	--
'Relay1 **'	Have the relay switch to status ...	open closed
'Relay2 **'	Have the relay switch to status ...	open closed
'Contact'	Switch over in this operating mode	--
'Batch (input)'	Switch over in this operating mode	--
'Analogue'	Switch over in this operating mode	--

** Option; needs to be assigned to the 'Timer' (under 'Settings → Inputs/Outputs → Relay → Relay type' - refer to this chapter of the operating instructions under 'Settings')

Tab. 15: Selected value ranges

Designation	Value range
Line numbers	01 ... 99
Day (date)	01 ... 28
Time of day (hours)	00 ... 23
Seconds	0001 ... 9999

12.4.2.1.2 'Init' Initial conditions

The triggering event 'Init' can be used to set initial conditions at the beginning of a program sequence.

Example

triggering event (trigger)		Action	
Init	-	Relay 2	closed
Init	-	Contact	-

The example means:

As soon as the programme is started (via 'Timer → Activation → active' or power supply on), 'Init' sets 'Relay 2' to 'closed' and the 'Operating mode' to 'Contact'.

12.4.2.1.3 Selecting cyclic time events and switching point

The cyclic time events periodically trigger actions. That is why a program line consists of a cycle and a switching point:

The **cycle** specifies after which time the action is to be repeated.

The **switching time** specifies when the action is to take place.

Example

Time events (triggers)		Action
Cycle	Switching time	
Workdays 1 (Mo-Fr)	Time of day 12:00	Manual

Tab. 16: Cyclic time events

Cycle	Time
'hourly'	hourly at mm. Minute
'daily'	daily at the time mm.ss, Monday to Sunday
'Workdays 1 (Mo-Fr)'	daily at the time mm.ss, Monday to Friday
'workdays 2 (Mo-Sa)'	daily at the time mm.ss, Monday to Saturday
'Weekend (Sa+Su)'	daily at the time mm.ss, Saturday and Sunday
'weekly'	weekly at the time mm.ss on day xxxxxx.
'monthly'	monthly at the time mm.ss on the day dd. Day* of the month

* Value range is restricted to day 01 – 28



CAUTION!

If you wish to use automatic summer time adjustment ('Settings' - 'Time') avoid in principle any time events between 02:00 and 03:00.



A time event lets you trigger an action precisely to the minute.

If the action is to be triggered precisely to the second, then you need to set up your programming on a delay.

12.4.2.2 1 time event - several actions

You can assign 1 time event to several actions. To do so, always use the same cycle and the same switching time! :

Example

No.	Time event (trigger)		Action	
01	Workdays 1 (Mo-Fr)	Time of day 12:00	Halt	-
02	Workdays 1 (Mo-Fr)	Time of day 12:00	Batch (input)	500 ml
03	Workdays 1 (Mo-Fr)	Time of day 12:00	Relay 1	-closed
04	-	-



- For details on the sorting sequence of the program lines see ↪ 'Sorting sequence' on page 65.
- The timer program can have a maximum of 99 program lines.

12.4.2.3 Check program lines ('Show')

☰ → 'Menu / Information → Timer → Set timer → Show'

'Show' lets you check individual program lines / instructions.

1. ➤ Press the [Clickwheel] on a program line / instruction.

⇒ This display appears:

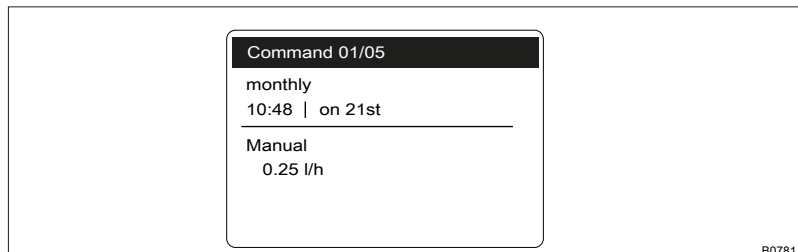

B0781

Above the line Time event (trigger) and possible value
 Below the line Action and value, if required

2. ➤ Turn the *[Clickwheel]*.

⇒ Scroll from instruction to instruction.

The number of the program line or instruction (and the number of the last program line or instruction) appears at the top in the dark bar.

3. ➤ Pressing the *[Clickwheel]* returns you to 'Set timer'.

As the timer software automatically sorts the program lines, the numbers of the program lines can change if you change something.

Sorting sequence

The timer software automatically sorts every newly programmed program line / instruction after completing it (press the *[Clickwheel]*) below the other program lines.

The 1st sorting criterion is the type of **time event (trigger)** (for the sequence refer to [Further information on page 62](#) and [Further information on page 63](#)).

Time-dependent program lines are ordered below each other initially after the **Switching point** (2nd sorting criterion)

then after the length of the **Cycle** (3rd sorting criterion).

The 4th sorting criterion is the type of **action** (see also the programming examples at the end of these instructions).

A purely time-controlled timer program will also run in this sequence.

12.4.2.4 Change program lines ('Change')

 ➤ 'Menu / Information ➔ Timer ➔ Set timer ➔ Change'

1. ➤ Use the *[Clickwheel]* to select the required program line / instruction according to its number and press the *[Clickwheel]*.**2.** ➤ Click through the instruction and change it.

⇒ The timer software sorts a changed program line / instruction after completion with the *[Clickwheel]* possibly differently in between the other program lines (Rules - see ['Sorting sequence' on page 65](#)).

12.4.2.5 Clear individual program lines ('Clear')

 ➤ 'Menu / Information ➔ Timer ➔ Set timer ➔ Clear'

1. ➤ Use the *[Clickwheel]* to select the required program line / instruction according to its number.**2.** ➤ The program line will be cleared as soon as you press the *[Clickwheel]*.

⇒ The timer software re-sorts the remaining programme lines (Rules - see ['Sorting sequence' on page 65](#)).

**Clear all program lines**

The option to clear all program lines is to be found one level higher in the menu:

 ➤ 'Menu / Information ➔ Timer ➔ Clear all'

12.4.3 Clear all

 → 'Menu / Information → Timer → Clear all → ...'

Use the 'Clear all' menu to clear all instructions (the entire program).

12.4.4 Examples

Requirements:

- You have already worked with the pump type
- The time has been set (possibly set under 'Settings → Set time → Time'. Only possible with 'Timer state' - 'Inactive').

Example of "Weekday metering"

Task:

The pump is to meter 2 litres every half hour every weekday (Mon-Fri) between 8:00 and 11:00.

Solution:

As you define switching times with the timer, you need to first define the switching points at 08:30, 09:30 and 10:30.





To meter 2 litres, the pump needs to work in 'Manual' 'Mode' for 10 min at a 'Dos. capacity' of 12,000 l/h. A 'Dos. capacity' of 12,000 l/h is thereby added to the switching points.

You also need to define the switching times to stop the pump at 08:40, 09:40 and 10:40 - paired with the 'Halt' action.

Tab. 17: Program as program lines / instructions

No.	Time event	Action			Comment
		Switching time		Capacity	
01	Workdays 1 (Mo-Fr)	08:30	Manual	12,000 l/h	Meter at 12,000 l/h
02	Workdays 1 (Mo-Fr)	08:40	Halt	-	Halt
03	Workdays 1 (Mo-Fr)	09:30	Manual	12,000 l/h	Meter at 12,000 l/h
04	Workdays 1 (Mo-Fr)	09:40	Halt	-	Halt
05	Workdays 1 (Mo-Fr)	10:30	Manual	12,000 l/h	Meter at 12,000 l/h
06	Workdays 1 (Mo-Fr)	10:40	Halt	-	Halt

How to enter the program lines / instructions:

1.  To program the timer, set  → 'Menu / Information → Timer → Activation' to 'inactive'.
 - ⇒ The first line of the timer menu 'Timer state' then shows 'inactive'.
2.  Always enter the program / instructions from the table, above, into the newly created instruction under 'Timer → Set timer → new → ...' (Do not get irritated: the timer program automatically sorts the instructions).
3.  To activate the timer, set 'Activation' to 'active'.
 - ⇒ The first line of the timer menu 'Timer state' then displays 'active'.

The timer starts working - the timer identifier  is visible in the continuous display.

4. Test your programming!

The secondary display "Timer" can help with this as it shows the next instruction and the remaining time. (To access this secondary display, press the [Clickwheel] in a continuous display until a long series of small circles appears below - immediately turn the [Clickwheel] to navigate to the last circle and press the [Clickwheel].)

The continuous display itself shows information on the current status of the pump in the dark bar.

**If something has been entered incorrectly:**

- Either press  in the current program line and enter the correct values
- or search for the program line in 'CHANGE' (automatic sorting!). Now press the [Clickwheel], allow the program to run through the program lines again and enter the values correctly
- or use 'Clear' to select the program line and clear
- or clear everything using 'Clear all' (one level higher).

12.4.5 Timer information

Status as soon as the programmed pump is connected to the power supply:

The timer software now generates the status of the pump which the pump would have precisely had at this time if it had not been disconnected from the power supply.

Effective settings after switching between Timer 'active' and 'inactive':

The timer settings are saved and become effective again when 'inactive' switches to 'active'.

The operating mode settings are saved and become effective again when 'active' is switched to 'inactive'.

Storage period of your programming:

The pump stores your programming for up to 20 years.

(The calibration and timer data is maintained for up to 100 years).

The time is retained without power supply for approx. 2 years.

12.4.6 Typical pitfalls Timer functional faults

Problem	Possible cause of fault	Remedy
The pump starts pumping unexpectedly.	The timer clears every "Manual" stop when activated - see "Timer behaviour on start"	Enter an 'Init' instruction with 'Halt' action.
The timer does not react to a contact signal at the corresponding pin of the "Config I/O" socket.	Config I/O was not configured as "Config I/O" - "Input" in the 'Menu / Information → Settings → Inputs/Outputs → ...' menu.	Configure Config I/O as "Config I/O" - "Input" in the 'Menu / Information → Settings → Inputs/Outputs → ...' menu.

Problem	Possible cause of fault	Remedy
The timer does not set a Config I/O output.	Config I/O was not configured as "Timer" - "Input" in the 'Menu / Information → Settings → Inputs/Outputs → ...' menu.	Configure Config I/O as a "Timer" - "Input" in the 'Menu / Information → Settings → Inputs/Outputs → ...' menu.
A 'Delayer' does not trigger an 'Action'.	Different delay times have been defined for the same 'Delayer' but this delayer is stopped and becomes inactive after the shortest delay time.	Create a further 'Delayer' for the longer delay time.

12.4.7 Brief explanation of selected functions

Time event (trigger)

An event can be triggered either time-dependent or event-controlled.

- 1 - Time events (really time-dependent) are processed precisely to the minute.
- 2 - Initialisation ('Init') is executed at the start of the program ('Timer → Activation → active' or when the power supply is connected) to obtain a defined status of the system.
- 3 - "Config I/O" inputs can trigger something if the input potential changes from 1 to 0 or with a falling edge or if the potential-free contact is closed.
- 4 - Delayers can trigger an action as soon as their time has expired - precisely to the second.

Actions

These are the 'Actions' which the timer executes as soon as a 'time event' has occurred.

Initialisation

When 'Activation' is set to 'active', the timer software generates the status of the pump which the pump would have precisely had at this time if it had been set to 'active' without any interruption.

This does not relate to delayed, linked actions.

The initial commands ('Init') can be used to program a defined switch-on status. Initial commands have priority over time commands.

Outputs

Those relays which were connected with the relay option are designated as outputs. There can be up to 2 relays.

Pins 1 - 3 of the "Config I/O" socket can be inputs and outputs. That can be programmed.

Inputs

Pins 1 - 3 of the "Config I/O" socket can be inputs and outputs. That can be programmed.

Delayer

Delayers are started event- or time-controlled. On expiry of the delay time, the delayer itself can trigger any actions.

12.5 'Service'

 → 'Menu / Information → Service → ...'

The 'Service' menu is split into the following sub-menus:

- 1 - 'Access protection'
- 2 - 'Password'
- 3 - 'Clear counters'
- 4 - 'Hose'
- 5 - 'Error log book'
- 6 - 'Display'
- 7 - 'Factory setting'
- 8 - 'Spare parts kit number'

12.5.1 'Access protection'

☰ → 'Menu / Information' → Service → Access protection → ...'

You can lock parts of the setting options here.

The following locking options are available:

Selection	Point ①	Point ②
'None'	-	-
'Lock menu'	X	-
'Lock all'	X	X

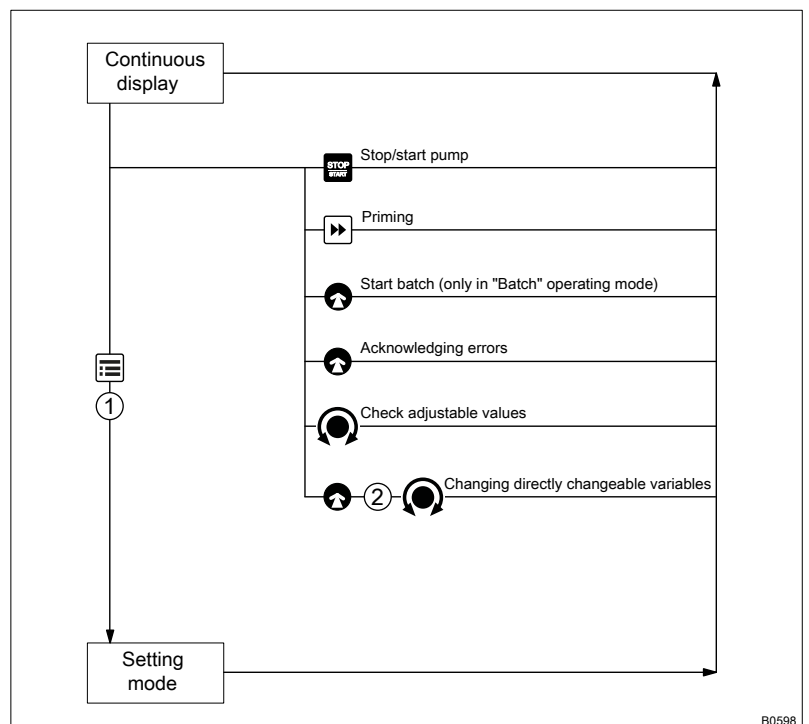



Fig. 31

If you have set a 'Password' - see below, then the identifier  will appear after 1 minute in the top left and the specified areas will be locked, if no key has been pressed in the meantime.

Both locks use the same 'Password'.

12.5.2 'Password'

 → 'Menu / Information → Service → Password → ...'

You can enter a password of your choice in the 'Change password' menu.

12.5.3 'Clear counters'

 → 'Menu / Information → Service → Clear counters → ...'

You can reset the counters to "0" in the 'Clear counters' menu:

- 'Number of revolutions'
- 'Volume counter' (total litres)
- 'All'

 To clear: exit the menu by briefly pressing the [Clickwheel].

The values have increased since commissioning the pump, the last calibration or the last deletion.



The "Hose service maintenance" counter can only be reset by going to the 'Tube Service' menu.

12.5.4 'Hose'

 → 'Menu / Information → Service → Hose → ...'

For this menu to appear, press  [STOP/START] to bring the pump to a stop (manually).

You can read or set various counters for hose operation in the 'Tube' menu:

- 'Hose interval'
- 'Hose service in'
- 'Revolutions since service'
- 'Interval counter'

The values have increased since pump commissioning or since they were last deleted.

Hose interval

Here you can change the interval for the hose replacement - the revolutions are counted in thousands.

As soon as the counter has counted down to "0", the LCD screen displays the 'Tube Service' warning. From this point on, the "Hose service maintenance" secondary display shows the revolutions counted as a negative figure so that the operator is able to better adapt the interval to the circumstances.

Expected service life of the pump hose



Determining the service life of the pump hose

When starting to pump, regularly check the pump hose for wear - do this several times a day if necessary. The service life and thus the replacement interval for the pump hose can be derived from the collected information and experience.

The service life of the pump hose is between approx. 600 and 1200 operating hours.

The following have a negative impact on the service life of the pump hose:

- high back pressure
- high speed
- high temperature
- abrasive feed chemicals
- exposure to chemicals
- long switching-on period.

Hose service in

Here you can see the number of hours in which the hose is to be replaced. The value displayed depends on the value in 'Tube interval'.

Revolutions since service

Here you can see how many revolutions the pump has performed since its last maintenance.

Interval counter

Here you can see the total number of hose replacement intervals the pump has experienced.

12.5.5 'Error log book'

→ 'Menu / Information → Service → Error log book → ...'

You can view the list of 'Error log books' here.

A 'Filter' helps with the overview.

12.5.5.1 Log book entry - detailed view

For more information about a log book entry, press the *[Clickwheel]*.

Tab. 18: Information on the detailed view

Line	Information
1	Date, time
2	Type of entry (fault, warning ...)
3	Total operating time, total revolutions
4	Switching-on duration, revolutions since switching on
5	Room temperature, additional information on the error (for developers)

12.5.6 *'Display'*

 → *'Menu / Information → Service → Display → ...'*

You can set the *'Contrast'* and the *'Brightness'* of the LCD screen here.

12.5.7 *'Factory setting'*

 → *'Menu / Information → Service → Factory setting → ...'*

For this menu to appear, press  [STOP/START] to bring the pump to a stop (manually).

You can reset the pump to its factory settings here by selecting *'Yes'*.

The password is 1812.

12.5.8 Spare parts kit number: XXXXXXXX

 → *'Menu / Information → Service
→ Spare parts kit part number: XXXXXXXX → ...'*

You can read the order number (part number) of the correct spare parts kit here.

12.6 *'Language'*

 → *'Menu / Information → Language → ...'*

You can select your required operating language in the *'Language'* menu.

13 Operation

User qualification: Instructed person - see  'Qualification of personnel' on page 14

This chapter describes all the operating options in a continuous display (several symbols and the pressure display appear at the top in the black bar) for the trained person at the pump.



– Please also refer to the "Operating/Setting overview" and "Continuous displays and secondary displays" overviews at the end of the operating instructions and also the "Overview of equipment and control elements" chapter.

13.1 Manual operation

Stop/start pump

Stop the pump: Press  [STOP/START].

Start the pump: Press  [STOP/START] again.

Priming

Press  [Priming].

Turn the [Clickwheel] to extend or shorten the priming time during priming.

Starting a batch

In 'Batch' operating mode: Press the [Clickwheel] in the 'Push' continuous display.

Acknowledge errors



Press the [Clickwheel] to acknowledge error messages that require acknowledgement.

Check adjustable variables

In a continuous display: Another continuous display appears each time the [Clickwheel] engages when turned. (The number depends on the configuration.)

Change directly adjustable variables

Changing a variable in the relevant continuous display:

1.  Press the [Clickwheel].
 - ⇒ The variable can be changed (highlighted).
2.  Turn the [Clickwheel].
 - ⇒ The variable is changed.
3.  Press the [Clickwheel].
 - ⇒ The variable is saved (the highlighting disappears).

If the "lock" - "lock all" has been set - see  'Set-up overview DULCO flex Control - DFXa' on page 74, first enter the 'Password' after pressing the [Clickwheel].

List of directly changeable variables:

- Capacity
- Contact volume
- Batch dosing time

- Concentration
- Time

Set-up overview DULCO flex Control - DFXa

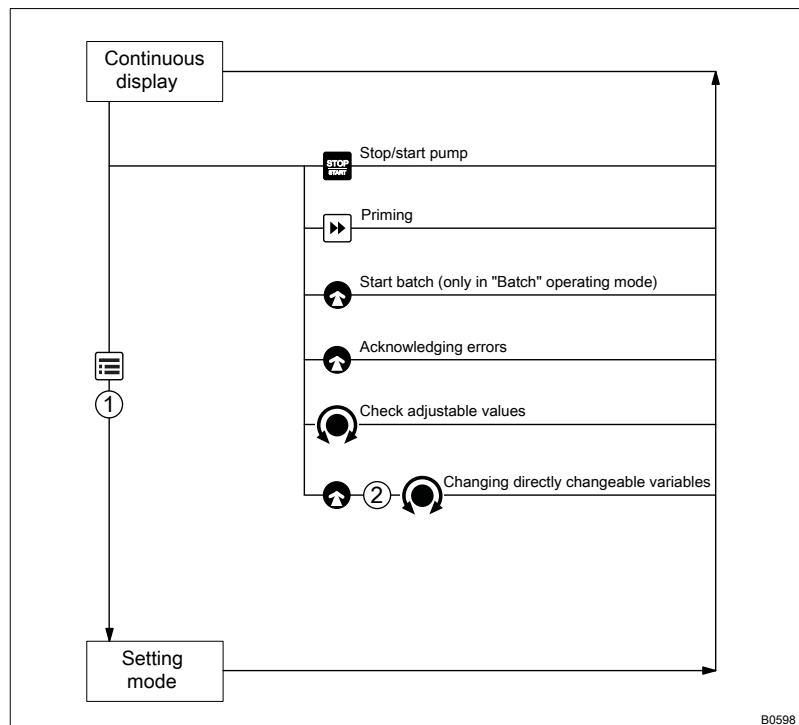

Fig. 32: Control options using keys and locking options

- ⬆️ Press [Clickwheel]
- ➡️ Turn [Clickwheel]
- ① "Lock menu"
- ② "Lock all"

14 Maintenance

User qualification: technical personnel and service, ↪ *'Qualification of personnel' on page 14*

Third-party spare parts for the pumps can lead to problems when pumping.

- Only use original spare parts.
- Use the correct spare parts kits - see order no. in the *'Service'* menu. If in doubt, refer to the ordering information in the appendix.

Before commencing all work

1. ➤ De-energise the pump.
2. ➤ Ensure that the pump is at atmospheric pressure.
3. ➤ If need be, then use a suitable flushing medium to flush the pump, referring to the material safety data sheet.

Interval	Maintenance work	Personnel
Quarterly*	<ul style="list-style-type: none"> ■ Check the pump hose for damage** - see Repair. ■ Clean the running surface in the dosing head and the rollers of the rotor. ■ Check that the hydraulic lines are fixed firmly to the liquid end. ■ Check the leak-tightness of the entire liquid end. ■ Dismantle the hose rupture sensor (option) and test with water. ■ Check that the front cover is fixed in place. ■ Check that the flow is correct: Press  [<i>Priming</i>] to allow the pump to prime briefly. ■ Check that the electrical connections are intact. ■ Check the integrity of the housing. 	Technical personnel

* with normal loading (approx. 30% of continuous operation).

With heavy-duty loading (e.g. continuous operation): Shorter intervals.

** Check the pump hose more frequently with feed chemicals that put particular pressure on the pump hose, e.g. substances containing abrasive additives or oxidation agents.

Expected service life of the pump hose

Determining the service life of the pump hose

- When starting to pump, regularly check the pump hose for wear - do this several times daily if necessary. The service life and thus the replacement interval for the pump hose can be determined through the information and experience you have gathered.
- You can enter the value for this replacement interval as a *'Tube interval'* in the *'Tube'* menu, and will be warned after it has expired - .

The following have a negative impact on the service life of the pump hose:

- High revolution rate
- High back pressure
- High temperature
- Abrasive feed chemicals
- Exposure to chemicals.

15 Repair

User qualification: qualified personnel and service: ☞ 'Qualification of personnel' on page 14

Safety information

Danger of electric shock.

- Unauthorised repairs inside the pump can result in an electric shock.
- For this reason, only allow a ProMinent branch or representative to perform repairs inside the pump, in particular the following:
- Replacement of damaged mains connection lines.
- Replacement of fuses.
- Replacement of the electronic control.

Contact with the feed chemical

- Wetted parts are exposed and touched during repair work.
- Protect yourself from the feed chemical. Read the material safety data sheet for the feed chemical.

Before commencing all work

1. ➤ De-energise the pump.
2. ➤ Ensure that the pump is at atmospheric pressure.
3. ➤ If need be, then use a suitable flushing medium to flush the pump, referring to the material safety data sheet.

15.1 Replacing the pump hose

User qualification: technical personnel and service, ☞ 'Qualification of personnel' on page 14

The rotating rotor may catch and trap body parts.

- Only replace the hose as outlined in the instructions below.

The part number of the appropriate spare parts kit can be found at the end of the 'Service' menu etc.

If you are fitting another type of hose, you need to share this with the pump control at ☰ ➤ 'Menu / Information ➤ Settings ➤ System ➤ Tube type'. Otherwise this could lead to problems.

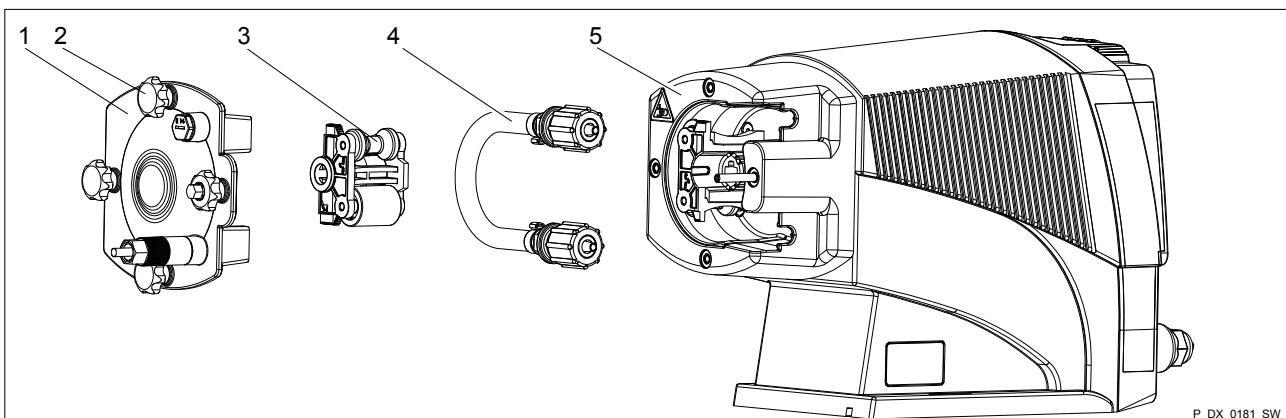





Fig. 33: Replacing the pump hose

- Ensure that the system is at atmospheric pressure.
 - Note the material safety data sheet for the feed chemical.
 - Prevent the escape of feed chemical.
 - Put in place protective measures, if necessary.
1. ➤ Press  [STOP/START] to bring the pump to a stop (manually).
 2. ➤ Drain the liquid end (turn the liquid end upside down and allow the feed chemical to run out and flush out with a suitable medium). Flush the liquid end thoroughly when using hazardous feed chemicals!

3. ➤ Go to the  → 'Tube Service' menu.
⇒ 'Go to change position?' appears.
4. ➤ The rotating rotor may catch and trap body parts.
 - Only remove the bearing cover once the pump prompts you to do so.
 - Refit the bearing cover once prompted to do so by the pump.
 Confirm the prompt with 'Yes'.
⇒ The rotor turns slowly and the following appears:
'Please Wait...'.
The rotor stops and *'Please remove cover and take out the Rotor!'* appears. (the corresponding rotor half flashes in the animation).
5. ➤ Loosen the 4 star-shaped screws (2) on the dosing head (5) and remove with the bearing cover (1).
6. ➤ Pull the rotor half (3) flashing in the LCD screen out of the dosing head (5) (if required, use a plastic tool to release it).
7. ➤ Press the Clickwheel.
⇒ The rotor turns slowly and the following appears:
'Please Wait...'.
The rotor stops and *'Please change the tube!'* appears.
8. ➤ Snap the two hydraulic connectors out of the dosing head (5) - away from the pump - and remove along with the pump hose (4).
9. ➤ Clean the liquid end if the pump hose (4) was leaking.
10. ➤ Check whether the running surface in the liquid end is level and smooth.
11. ➤ Thoroughly grease the new pump hose (4) and the running surface in the liquid end with the silicone grease provided.
12. ➤ Insert the new pump hose (4) into the dosing head (5) and snap the two hydraulic connectors into place - round side into the dosing head (5).
13. ➤ Press the Clickwheel
⇒ The rotor turns slowly and the following appears:
'Please Wait!'.
The rotor stops and *'Insert rotor again!'* appears.
14. ➤ Reinsert the rotor half (3) removed - the surfaces of the two rotor halves must be perfectly flush.
15. ➤ Press the Clickwheel.
⇒ The rotor turns and the following appears:
'Please Wait...'.
The rotor stops - this time standing on its tip - and *'Install Cover again!'* appears.
16. ➤ Place the bearing cover (1) on the dosing head (5).
17. ➤ Initially only loosely screw all 4 star-shaped screws (2) into the dosing head (5).
18. ➤ Manually tighten the 4 star-shaped screws (2). Screw the domed nut onto the 4th star-shaped screw again and tighten it to provide a locking function.
19. ➤ Press the Clickwheel.
⇒ 'Run in tube?' appears.
'Yes' / 'No'

20. ▶ Selecting *[No]* exits this macro.
The pump hose (4) is drawn in if 'Yes' is selected.
⇒ 'Run in tube ...' appears.
The rotor turns a couple of times.
21. ▶ The 'Tube change interval' menu appears.
In the first 'Revolutions' menu item, you have the option of extending or shortening the warning time for the next hose change by changing the 'Revolutions' - also refer to 'Service → Tube'.
22. ▶ Press the *[Clickwheel]* to reset the warning time.
⇒ 'Reset interval now!' appears.
23. ▶ Press the *[Clickwheel]* again to complete the hose change.
⇒ 'Complete!' and a hand symbol appear. This is a reminder that the pump still needs to be stopped manually. If necessary, now restart the pump using the  *[STOP/START]* key.
24. ▶ If the pump hose was ruptured, clean the hose rupture indicator (optional).

15.2 Cleaning the hose rupture indicator (optional)

Unnoticed escape of feed chemical



- Once the hose rupture indicator has been triggered, any residue of feed chemical may affect the function of the hose rupture indicator.
 - Clean and test the hose rupture indicator after it has been triggered.
1. ▶ Unscrew the hose rupture indicator using an AF 14 open-ended spanner.
 2. ▶ Use a suitable liquid to clean the hose rupture indicator, if possible using water.
 3. ▶ Test the connected hose rupture indicator: fully immerse the tapered section at the front in water.
⇒ The continuous display indicates a hose rupture.
 4. ▶ Thoroughly dry the hose rupture indicator.
⇒ The continuous display no longer indicates a hose rupture.
 5. ▶ Screw the clean and dry hose rupture indicator into the hole until hand-tight and liquid-tight.

16 Rectifying functional faults

User qualifications - see the following tables and  'Qualification of personnel' on page 14

Safety information

Before commencing all work

1.  De-energise the pump.
2.  Ensure that the pump is at atmospheric pressure.
3.  If need be, then use a suitable flushing medium to flush the pump, referring to the material safety data sheet.

16.1 Faults without error message

Faults without error message





Fault description	Cause	Remedy	Personnel
Fluid is escaping from the liquid end.	The pump hose is not leak-tight.	Replace the pump hose - refer to the "Repair" chapter. If a pump hose rupture has been indicated, clean the hose rupture indicator - refer to the "Repair" chapter.	Technical personnel
Green LED display (operating indicator) does not light up.	The wrong supply voltage or no supply voltage is connected.	The specified supply voltage as per the voltage specification can be found on the nameplate.	Electrician

16.2 Fault with error message

16.2.1 Fault messages on the LCD screen



In the event of a fault:

- the red LED display lights up.
- an identifier and a message appear on the LCD screen.
- the pump stops.

Fault description	Cause	Remedy	Personnel
No. 0: The identifier  and the message 'System error' appear.	System or EPROM error	Return the pump to ProMinent.	Instructed personnel
No. 1: The identifier  appears followed by the message 'Input signal < 4 mA'.	The pump is in 'Analog' operating mode, a fault behaviour has been programmed in the 'Analog' menu and the control current has fallen below 4 mA.	Eliminate the cause of the low control current or Switch the programming of the fault behaviour to 'off' - see chapter "Set up"-"Settings"-"Operating mode"-"Analog".	Technical personnel
No. 2: The identifier  appears followed by the message 'Input signal > 20 mA'.	The pump is in 'Analog' operating mode, a fault behaviour has been programmed in the 'Analog' menu and the control current has risen above 20 mA.	Eliminate the cause of the high control current or Switch the programming of the fault behaviour to 'off' - see chapter "Set up"-"Settings"-"Operating mode"-"Analog".	Technical personnel
No. 3: The identifier  appears followed by the message 'Level error!'.	The fluid level in the supply tank has reached "Liquid level low 2nd stage".	Top up the supply tank.	Technical personnel
No. 4: The identifier  and the message 'Tube rupture' appear.	The pump tube has a leak.	Press the [Clickwheel].	Technical personnel

Rectifying functional faults









Fault description	Cause	Remedy	Personnel
No. 4: The identifier  and the message 'Tube rupture' appear.	The pump tube has a leak.	Replace the pump tube and clean the tube rupture indicator, refer to the "Repair" chapter.	Technical personnel
No. 7: The identifier "Temperature"  appears followed by the message 'Temperature' and the pump remains idle.	The ambient temperature is too high or too low.	Change the ambient temperature. The pump starts up automatically.	Technical personnel
	The temperature is too high.	Rectify the cause. The pump starts up automatically.	Technical personnel
No. 8: The identifier  and the message 'Initialisation' appear.	Pump restart, initialisation incomplete.	Rectify the cause. The pump starts up automatically.	Technical personnel
No. 10: The identifier  and the message 'Parameter' appear.	An incorrect parameter has been entered.	Correct the parameter.	Technical personnel
No. 13: The identifier  and the message 'Mains/power supply / overvoltage' appear.	The supply voltage is too low or not connected.	Rectify the cause.	Technical personnel
No. 16: The identifier  and the message 'Memory overflow' appear.	The amount of memory space reserved for the stack is no longer sufficient.	Perform a reset (briefly disconnect from the mains/power supply).	Technical personnel
No. 17: The identifier  and the message 'Control signal < Imin' appear.	The pump is in 'Analog'-"xx. side band" operating mode, a fault behaviour has been programmed in the 'Analog' menu and the control current has fallen below 4 mA.	Eliminate the cause of the low control current or Switch the programming of the fault behaviour to 'off' - see chapter "Set up"- "Settings"- "Operating mode"- "Analog".	Technical personnel
No. 18: The identifier  and the message 'Control signal > Imax' appear.	The pump is in 'Analog'-"xx. side band" operating mode, a fault behaviour has been programmed in the 'Analog' menu and the control current has risen above 20 mA.	Eliminate the cause of the high control current or Switch the programming of the fault behaviour to 'off' - see chapter "Set up"- "Settings"- "Operating mode"- "Analog".	Technical personnel
No. 20: The identifier  and the message 'Module missing' appear.	The optional module is missing.	Insert the optional module.	Technical personnel
	Communication between the optional module and pump electronics is not working.	Return the pump to ProMinent.	
No. 21: The identifier  and the message 'Module communication' appear.	Communication between the optional module and pump electronics is not working.	Rectify the cause.	Technical personnel
No. 22: The identifier  (internal) and the message 'Internal CAN bus' appear.	The associated heartbeat message was no longer received by the front assembly for a certain period of time.	Rectify the cause.	Technical personnel
No. 23: The identifier  and the message 'Version error' appear.	Problems with compatibility with the assemblies' firmware.	Return the pump to ProMinent.	Instructed personnel
No. 24: The identifier  and the message 'System error' appear.	System or EPROM error	Return the pump to ProMinent.	Instructed personnel
No. 25: The identifier  and the message 'Initialisation' appear.	Pump restart, initialisation incomplete.	Rectify the cause.	Technical personnel
No. 26: The identifier  and the message 'Motor Error' appear.	The motor indicates a fault.	Return the pump to ProMinent.	Technical personnel
No. 27: The identifier  and the message 'Fan warning' appear.	The fan is faulty or not connected.	Return the pump to ProMinent.	Instructed personnel

Fault description	Cause	Remedy	Personnel
No. 28: The identifier  (drive) and the message 'Communication interrupted' appear.	RS485 communication is interrupted.	Rectify the cause.	Technical personnel
No. 30: The identifier  and the message 'Motor blockage' appear.	The motor is blocked.	Return the pump to ProMinent.	Instructed personnel

16.2.2 Warning messages on the LCD screen

In the event of a warning:

- the yellow LED display lights up!
- an identifier and a message appear on the LCD screen.

Fault description	Cause	Remedy	Personnel
No. 0: 'Level' and the identifier  appear.	The fluid level in the supply tank has reached "Liquid level low 1st stage".	Top up the supply tank.	Instructed personnel
No. 1: The identifier  and the message 'Tube Service' appear.	The set pump tube service life has elapsed. (Adjust -  Chapter 12.5.4 'Hose' on page 70.).	Replace the pump tube - refer to the "Repair" chapter.	Technical personnel
No. 3: The identifier  and the message 'Invalid metering volume' appear.	The set metering volume in concentration mode cannot be metered.	Adjust the metering parameters.	Technical personnel
No. 4: The identifier  and the message 'Invalid parameter' appear.	A set parameter is invalid.	Adjust the parameter.	Technical personnel
No. 5: The identifier  and the message 'Fan warning' appear.	The fan is faulty or not connected.	Return the pump to ProMinent.	Instructed personnel
No. 12: The identifier  and the message 'Invalid metering volume' appear.	The set metering volume in concentration mode cannot be metered.	Adjust the metering parameters.	Technical personnel
No. 13: The identifier  "Temperature" and the message 'Temperature' appear.	The temperature is too high.	Rectify the cause. The pump starts up automatically.	Technical personnel

16.2.3 All other faults

Please contact the responsible ProMinent branch or representative!

16.3 Log book

16.3.1 Fault messages in the log book



For more information on the 'ERROR' messages - refer to the chapter "Fault messages on the LCD screen".

Rectifying functional faults

Tab. 19: Errors

Log book no.	Description	Acknowledge?
0	System, EEPROM error *	X
1	The pump is in 'Analog' operating mode, a fault behaviour has been programmed in the 'Analog' menu and the control current has fallen below 4 mA.	-
2	The pump is in 'Analog' operating mode, a fault behaviour has been programmed in the 'Analog' menu and the control current has risen above 20 mA.	-
3	The fluid level in the supply tank has reached "Liquid level low 2nd stage".	-
4	The pump tube has a leak.	-
5	-	-
6	-	-
7	Temperature error	-
8	Pump restart, initialisations incomplete.	-
9	-	-
10	An incorrect parameter has been entered.	X
11	-	-
12	-	-
13	The supply voltage is too low or not connected.	-
14	-	-
15	-	-
16	The memory for revolutions, which have not yet been processed, has overflowed.	-
17	Control signal < Imin (if current monitoring switched on)	-
18	Control signal < Imax (if current monitoring switched on)	-
19	-	-
20	Module missing *	-
21	Communication between the optional module and pump electronics is not working.	-
22	The associated heartbeat message was no longer received by the front assembly for a certain period of time.	-
23	Problems with compatibility with the assemblies' firmware. *	X
24	System or EPROM error	X
25	Pump restart, initialisation incomplete.	-
26	The motor indicates a fault.	-
27	The fan is faulty or not connected. *	-
28	RS485 communication is interrupted.	-
29	The motor indicates a fault.	-
30	The motor is blocked. *	X

* Please get in touch with the ProMinent head office should this fault occur.

16.3.2 Warning messages in the log book





For more information on the 'WARNING' messages - refer to the chapter "Warning messages on the LCD screen".

Tab. 20: Warnings

Log book no.	Description
0	The fluid level in the supply tank has reached "Liquid level low 1st stage".
1	Tube service time has expired.
2	-
3	The set metering volume cannot be metered.
4	A set motor parameter is invalid.
5	The fan is faulty or not connected.
6	-
...	...
11	-
12	The set metering volume cannot be metered.
13	The temperature is too high.

16.3.3 Event messages in the log book

Tab. 21: Events

Log book no.	Description
0	Head installation changed
1	Call up the parameter menu
2	-
3	-
4	-
5	-
6	-
7	The pump was reset to factory settings.
8	The pump was calibrated.
9	 [START/STOP] was pressed.
10	 [Priming] was pressed.
11	The [Clickwheel] was pressed.
12	The pump tube was replaced.
13	The timer performed an action.
14	A relay has triggered.
15	The dosing direction was changed.

Log book no.	Description
16	CRC error has been detected in the EEPROM data. Log book: [hh ll 00 00] hh – MSB address ll – LSB address [00 00 rr ss] ss – Structure rr – Result
17	-
18	The metering volume cannot be metered.
19	The pump has been booted and is operational.

16.3.4 Log book entry - detailed view

For more information about a log book entry, press the *[Clickwheel]*.

Tab. 22: Information on the detailed view



Line	Information
1	Date, time
2	Type of entry (fault, warning ...)
3	Total operating time, total revolutions
4	Switching-on duration, revolutions since switching on
5	Room temperature, additional information on the error (for developers)

17 Decommissioning and disposal

User qualification: technical personnel and service - see  'Qualification of personnel' on page 14



Decommissioning

Before commencing all work

1.  De-energise the pump.
2.  Ensure that the pump is at atmospheric pressure.
3.  If need be, then use a suitable flushing medium to flush the pump, referring to the material safety data sheet.

Danger of damage to the unit

Take into account the information in the "Storage, transport and unpacking" chapter if the system is decommissioned for a temporary period.

1.  Disconnect the pump from the mains/power supply.
2.  Drain the liquid end by turning the pump upside down and allowing the feed chemical to run out.
3.  Flush the liquid end with a suitable medium; flush the dosing head thoroughly when using hazardous feed chemicals!

Disposal

Risk to the environment from the battery

- There is a battery in the pump, which can have a toxic effect on the environment.
- Disconnect the battery from the remaining parts.
- Note the pertinent regulations currently applicable in your country.

Environmental hazard due to gear oil

- There is gear oil in the pump, which can have a toxic effect on the environment.
- Drain the gear oil from the gear in accordance with the operating instructions.
- Note the pertinent regulations currently applicable in your country.

Environmental hazard due to electronic waste

- There are components in the pump, which can have a toxic effect on the environment.
- Note the pertinent regulations currently applicable in your country.

18 Technical data

18.1 Performance data

DULCO flex Control - DFXa, DFXa

Liquid end type	Minimum dosing rate at maximum back pressure		lowest possible dosing rate	Revolution rate, max.	Connector size outer Ø x inner Ø	Suction lift* = priming lift	Permissible priming pressure on the suction side	Weight
	bar	l/h						
0518	5 *	18	6	100	12x9	9	1	5.8
0530	5 *	30	10	100	12x9	9	1	5.8
0730	7 *	30	10	100	12x9	9	1	5.8
0565	5 *	65	22	100	12x9	9	1	5.8

* depending on the tube material

Data calculated with water at 20°C.

The pump capacity is reduced with gas bubbles in the feed chemical.

18.2 Precision

Tab. 23: Precision

Parameter	Value
Capacity range of the product range	-5 ... + 5%
Reproducibility	±1% with a new pump hose after approx. 200 revolutions.

18.3 Viscosity

The liquid ends are suitable for the following viscosity ranges:

Tube material	Range	Unit
TPV	0.7 ... 10,000	mPas
PUR	0.7 ... 200,000	mPas

18.4 Material specifications

Part	Material
Pump hose *	TPV or PUR
Hose connection *	PVDF
O-rings *	PTFE
Dosing head	PA6 50 % GB
Rotor	PPS 40 % GF
Rollers on the rotor	PA66
Bearing cover	PC
Housing upper part	PPE + 20 % GF
Housing lower part	PPE + 20 % GF
Cable threaded connectors	PA6
Metal parts (screws, etc.)	A2

* wetted

18.5 Electrical data

Design: 100 - 230 V ±10%, 50/60 Hz

Data	Value	Unit
Nominal power, approx.	50	W
Current I_{eff}	0.45 ... 0.20	A
Fuse	1.6	A slow-blow

Fuses must have VDE, UL and CSA certification: SPT series, 1.6 amps supplied by Schurter® Order. No. 0001.2506 according to IEC Publ. 127 - 2/3 etc.

Overvoltage category

Overvoltage category: II

18.6 Temperatures

Pump, fully assembled

Data	Value	Unit
Storage and transport temperatures:	- 10 ... +50	°C
Ambient temperature in operation (power end/drive and control):	0 ... +45	°C
Feed chemical temperature	+5 ... +45	°C
Feed chemical temperature, temporary (5 min)	+80	°C

18.7 Climate

Air humidity, max. 95% relative humidity, non-condensing.

Exposure in a humid and changing climate:

FW 24 according to DIN 50016

Wet location

Wet location: No

18.8 Altitude of site

Data	Value	Unit
Altitude of site , max.:	2000	m above NHN

18.9 Degree of protection and safety requirements

18.9.1 Degree of protection

Protection against contact and moisture: The pump is designed in accordance with: IP 66 (EN 60529) and NEMA-4X/indoor (NEMA 250)

18.9.2 Safety requirements

Degree of protection: 1 - Mains connection with protective earth conductor

18.9.3 Degree of pollution

Degree of pollution: 2

18.10 Sound pressure level

Sound pressure level

Sound pressure level LpA < 70 dB according to EN ISO 20361 at maximum feed rate and maximum back pressure (water)

18.11 Suction lance, continuous

The suction lance with continuous level measurement is configured for 30-litre standard canisters and this pump.

The suction lance works with feed chemicals containing water. The dielectric constant must be high.

Hose connector	Order no.	Dimensions* approx. Ø x length
6 x 4 mm	1094379	74.5 x 571 mm
8 x 5 mm	1094382	74.5 x 571 mm
12 x 9 mm	1094380	74.5 x 571 mm

* without cable and hose (3 m)

Specification	Value
Precision, based on the measuring section:	5%

Specification	Value
Storage and transport temperature:	-10 ... +50 °C
Ambient temperature during operation:	-10 ... +45 °C
Medium temperature:	-10 ... +50 °C

Specification	Value
Protection against contact and moisture according to EN 60529:	IP67
Relative humidity	max. 95%, non-condensing

Component	Materials
Suction lance	
Pipe, hose and screw cap	PE
Adapter, valve insert, clamping ring, hose sleeve, valve seat, distance sleeve, screen plate	PVDF
Electronics	Electronic components
Flat seal	PTFE
Valve ball	Ceramic
Level measurement	
Heat shrink hose	PLG / PVDF
Housing parts	PP GF30
Seal	TPE

19 Dimensional drawings

Dimensional drawing

- Compare the dimensions on the dimensional drawing with those of the pump.
- All dimensions are in mm.

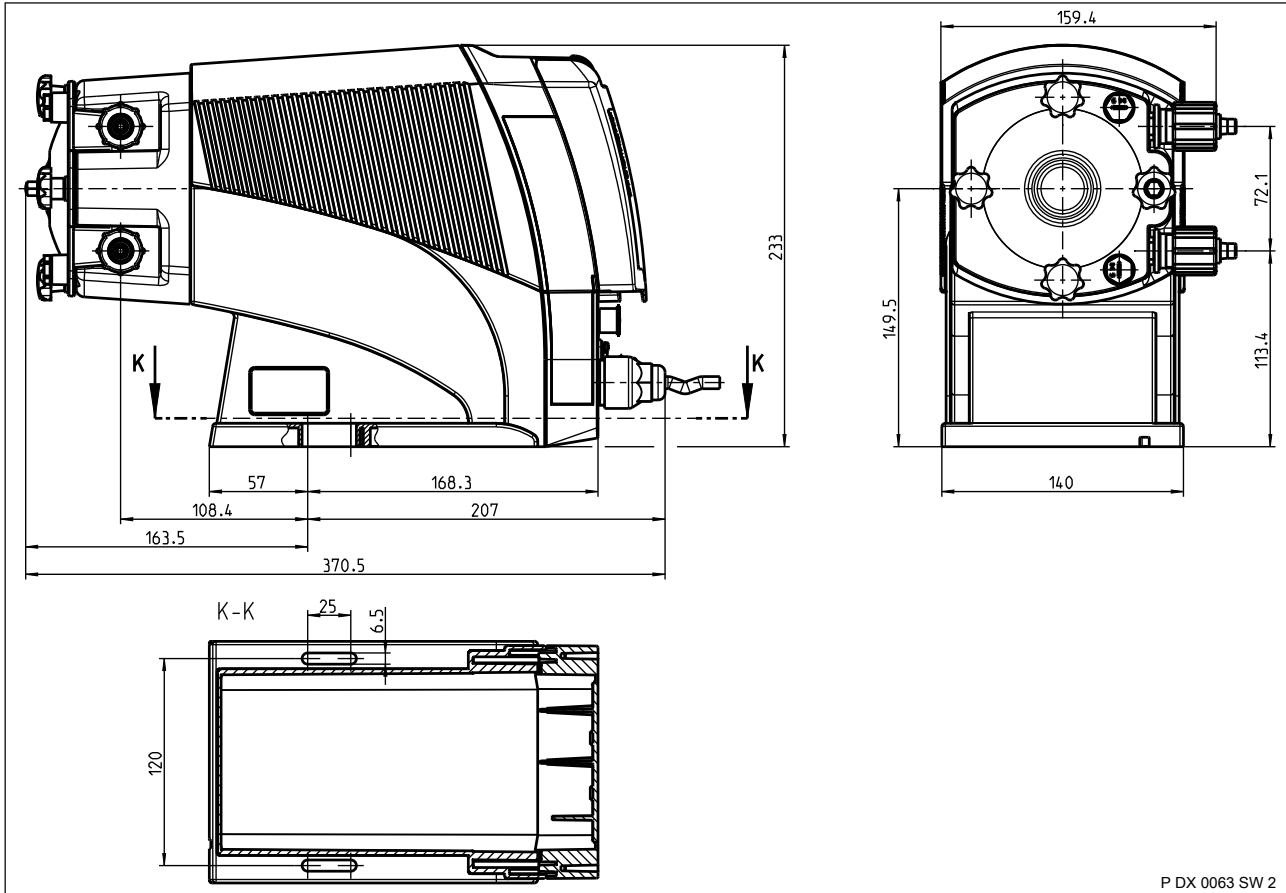

Fig. 34: Version with "dosing head orientation": "R = right", with "hydraulic connector": "0 = 12x9", with "hose rupture indicator": "0 = none". Diagram is not strictly binding.

20 Diagrams for adjusting the pump capacity

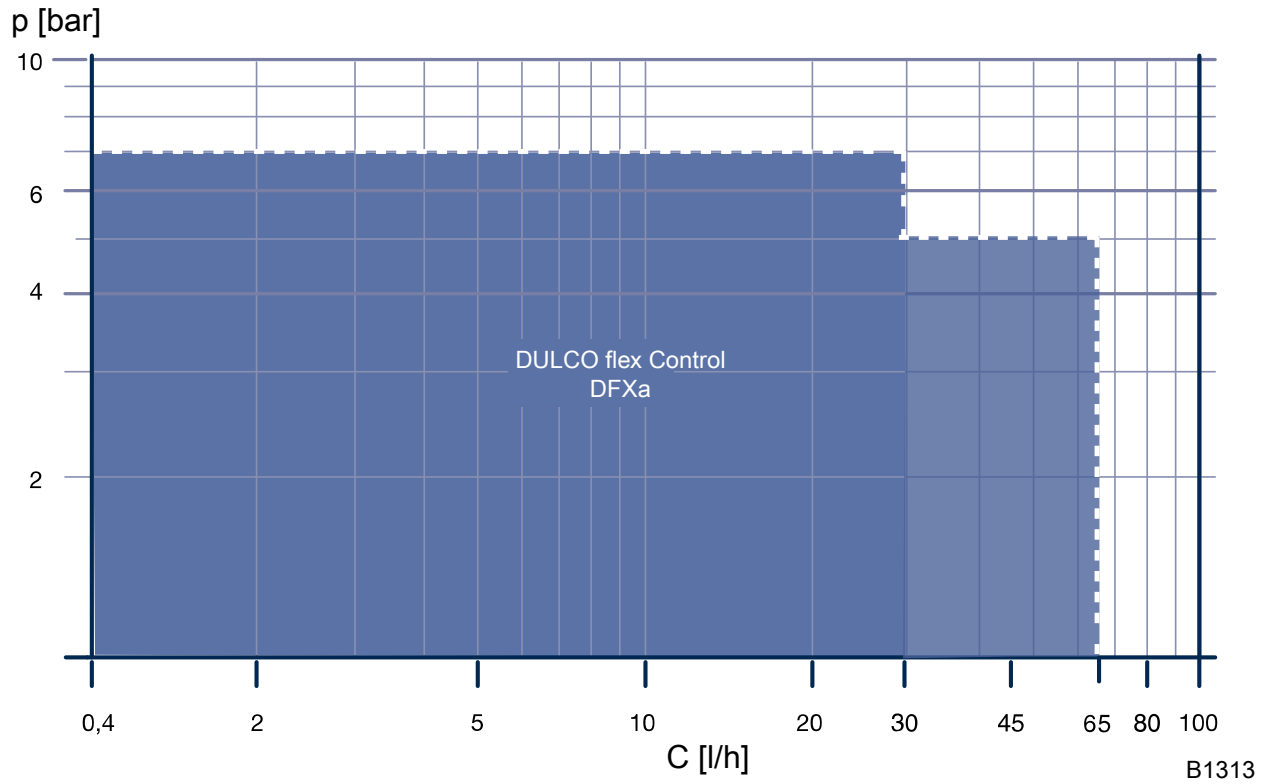

Fig. 35: Performance diagram for DFXa - pressure p against feed rate C

21 Declaration of Conformity for Machinery

In accordance with DIRECTIVE 2006/42/EC OF THE EUROPEAN PARLIAMENT AND OF THE COUNCIL, Appendix I, BASIC HEALTH AND SAFETY REQUIREMENTS, section 1.7.4.2. C.

We,

- ProMinent GmbH
- Im Schuhmachergewann 5 - 11
- D - 69123 Heidelberg, Germany,

hereby declare that the product specified below complies with the relevant basic health and safety requirements of the EC Directive on the basis of its functional concept and design and in the version marketed by us.

Any modification to the product not approved by us invalidates this declaration.

Tab. 24: Excerpt from the Declaration of Conformity

Designation of the product:	Peristaltic metering pump DULCO flex Control
Product type:	DFXa...
Serial number:	see nameplate on the device
Relevant directives:	Machinery Directive (2006/42/EC) Compliance with the protection targets of the Low Voltage Directive according to Annex I, No. 1.5.1 of the Machinery Directive (2006/42/EC) EMC Directive (2014/30/EU) RoHS Directive (2011/65/EU)
Harmonised standards applied, in particular:	EN ISO 12100: 2010 EN 809:1998 + A1:2009 + AC:2010 EN 61010-1:2010 EN 61000-6-2:2005 + AC:2005 EN 61000-6-4:2007 + A1:2011 EN 50581:2012
Date:	01.08.2019

You can download the Declaration of Conformity at www.prominent.com.

22 UK Declaration of Conformity

We,

- ProMinent GmbH
- Im Schuhmachergewann 5 - 11
- D - 69123 Heidelberg
- Germany

hereby declare that the product identified below conforms to the basic health and safety requirements of the Regulations, by virtue of its design and construction, and in the configuration placed on the market by us.

This declaration is no longer applicable if changes are made to the product without our authorisation.

Tab. 25: Extract from the Declaration of Conformity

Product description:	DULCO flex Control hose pump
Product type:	DFXa...
Serial no.:	see type plate on the unit
Applicable Regulations:	Supply of Machinery (Safety) Regulations 2008 The safety objectives of the Electrical Equipment (Safety) Regulations 2016 were complied with in accordance with Appendix 1, No. 1.5.1 of the Supply of Machinery (Safety) Regulations 2008 Electromagnetic Compatibility Regulations 2016 Restriction of the use of certain hazardous substances in electrical and electronic equipment regulations 2012
Applied standards, especially:	BS EN ISO 12100: 2010 BS EN 809:1998 + A1:2009 BS EN 61010-1:2010 BS EN 61000-6-2:2005 BS EN 61000-6-4:2007 + A1:2011 BS EN IEC 63000:2018
Date:	23.02.2021

You will find the UK Declaration of Conformity to download on our home-page.

23 Operating / set-up overview DULCO flex Control - DFXa

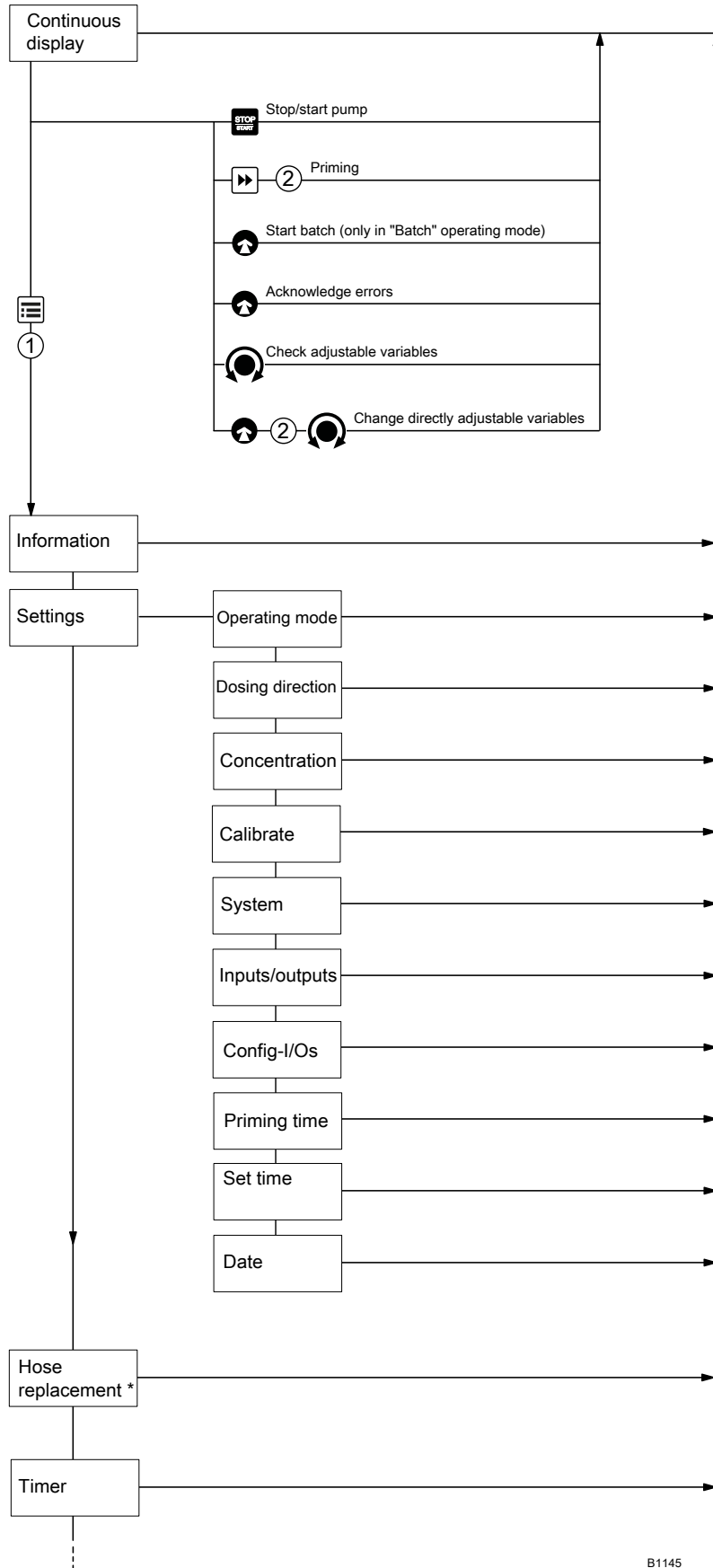

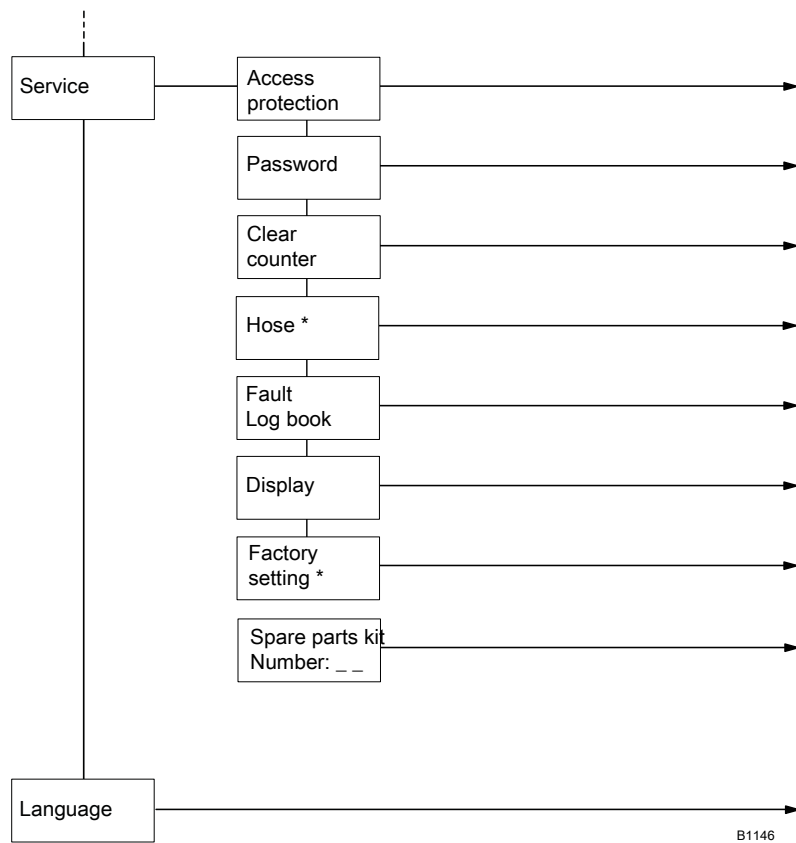

* For this menu to appear, press  [STOP/START] to bring the pump to a "Stop (manually)".

24 DULCO flex Control - DFXa operating menu, overall

1st level	2nd	3rd	4th	5th	xth
Information	Versions	Control	Hardware Software Bootloader		
		Power	Hardware Software Bootloader		
		HMI data			
	Time				
	Date				
	Serial number				
	Identity code				
	Max. metering capacity				
	Switch-on counter				
	Total operating time				
	Total number of revol.				
	Total metering volume				
	Current volume per revolution				
	Settings	Operating mode	Manual		
Contact			<i>Memory</i> On Off	Metering volume *1	..
Batch			<i>Memory</i> On Off	Metering volume *1	...
Analog			0...20 mA		
			4...20 mA		
			Linear curve ** Lower side band ** Upper side band **	Curve point 1 (I1,F1)	...
Dosing direction		Clockwise Counter-clockwise			
Concentration		Concentration control active inactive	Flow of main medium (for Manual)	Concentration of feed chemical	...
			Contact distance (for Contact)	Concentration of feed chemical	...
			Volume main medium (for Batch)	Concentration of feed chemical	...

DULCO flex Control - DFXa operating menu, overall

1st level	2nd	3rd	4th	5th	xth
			Max. flow of main medium (for Analog)	Concentration of feed chemical	...
	Calibrate	Calibr. factor	Calibr. factor		
		Calibrate *	Start calibration	Calibration ended	Calibration result
	System	Tube type	PUR_5BAR_18L TVP_5BAR_30L TPV_7BAR_30L PUR_5BAR_30L PUR_5BAR_65L		
		Config. Dosing head	right left top bottom		
		Volume unit	Litres Gallons (U.S.)		
		Start behaviour	always STOP always on Last state		
	Inputs/outputs	Auxiliary mode	Auxiliary capacity	...	
		Relay 1	Relay 1 type	Timer Error Warning Warning + error Warning + error + stop Pump active Metering / Batch	
			Relay 1 polarity	Energizing (NO) Releasing (NC)	
		Relay 2	Relay type	Timer Error Warning Warning + error Warning + error + stop Pump active Cycle quantity Revolution rate Metering / Batch	
			Polarity	Energizing (NO) Releasing (NC)	

DULCO flex Control - DFXa operating menu, overall

1st level	2nd	3rd	4th	5th	xth
		mA-Output	0...20 mA 4...20 mA	Capacity at 20mA	...
		Flow monitoring	Flow Control	Tolerance / revolutions Activation at auxiliary	...
		Pause input	Break contact Make contact		
		Niveau monitoring	two stage continuous		
	Config-I/Os	Set Config-I/Os	Config-I/O 1 Config I/O 2 Config-I/O 3	off Timer input Timer output AUX Selective fault Selective warning Cycle quantity Metering / Batch Error Warning Warning + error Warning, error + stop Pump active	...
		Config-I/O 1 xxxxxx Config-I/O 2 xxxxxx Config-I/O 3 xxxxxx			
	Priming time	0 ... 60 s			
	Set time	Time	Set up	hh.mm.ss	
		Auto. summer time	Yes No		
		Summer time begin in	February March April		
		Sunday the	1st, 2nd, 3rd, 4th, 5th		
		Summer time end in	August September October November		
		Sunday the	1st, 2nd, 3rd, 4th, 5th		

1st level	2nd	3rd	4th	5th	xth
		Location	Northern hemisphere Southern hemisphere		
	Date	dd.mm.yyyy			
Tube change *	Go to change position?	No Yes	...		
Timer	Timer status				
	Activation	Active Inactive			
	Setting the timer	New Displays Change Clear	Instruction 01 Instruction2 ...	Hourly Daily (Mon-Sun) Weekdays1 (Mo-Fr) Weekdays2 (Mo-Sa) Weekend (Sa+Su) Weekly Monthly Init Delayer Config I/O 1 Config I/O 2 Config I/O 3	...
	Clear all	No Yes			
Service	Access protection	<i>Password?</i>	None Lock menu Lock all		
	Password	<i>Password?</i>	0000		
	Clear counters	Revolution counter Volume counter All			
	Tube *	Tube interval Tube service in xxx h Revolutions since service Interval counter			
	Error-Logbook	Error-Logbook	...		
		Filter	None only warn.+errors only errors only warnings only events		
	Display	Brightness			

DULCO flex Control - DFXa operating menu, overall

1st level	2nd	3rd	4th	5th	xth
		Contrast			
	Factory setting *	<i>Password?</i>	Yes No		
	Spare part kit number: XXXXXXXX				
Language (<i>Language</i>)	English Deutsch Français Español Italiano Polski ...				



Menus may be missing or added depending on the design and equipment on the pump.

* For this menu to appear, press  [STOP/START] to bring the pump to a "Stop (manually)".

** not available with mA-Output.

25 Continuous displays and secondary displays

Continuous displays

Continuous display	mode " Manual "	mode " Contact "	mode " Batch "	mode " Analog "
Capacity	12:00 _{in}	12:00 _{in}	12:00 _{in}	12:00 _{in}
Contact volume		1250 ^{1/2}	1250 ^{1/2}	
Batch dosing time			90 _s	
Concentration	03.5 %	03.5 %	03.5 %	03.5 %
Trigger batch				
Time	16:12:21	16:12:21	16:12:21	16:12:21

Auxiliary displays in the continuous display

Secondary display	mode " Manual "	mode " Contact "	mode " Batch "	mode " Analog "
Capacity	12.00 L /h			12.00 L /h
Remaining litres			000, 833 ↓ I ¹	
Hose service Warning	1613 h	1613 h	1613 h	1613 h
Total number of revol.	602371 ⌚	602371 ⌚	602371 ⌚	602371 ⌚
Total litres	2949.6 l	2949.6 l	2949.6 l	2949.6 l
Signal current (at the input)				12, 7 mA ²
Time	16:12:21	16:12:21	16:12:21	16:12:21
Date	2015 - 03 - 27	2015 - 03 - 27	2015 - 03 - 27	2015 - 03 - 27
Relay status	Relay 1: on Relay 2: off ³	Relay 1: on Relay 2: off ³	Relay 1: on Relay 2: off ³	Relay 1: on Relay 2: off ³

1 = only with "Storage tank" function extension

2 = only with current output

3 = only with relay

26 Installation instructions: Retrofitting, relays

Tab. 26: These installation instructions apply to:

Designation	Order no.
Fault indicating relay	1050643
Fault indicating and pacing relay	1050654
Fault indicating relay + 4-20 mA output	1050655

Materials

Torx spanner T 25.

A pocket torch can help to find the 4x2 contact in the slot for the relays more easily.

Requirement:

Personnel: ■ Electrician

Scope of delivery

- 1 - Relay board, fully assembled.
- 1 - Relay cable, fully assembled, with connector.
- 1 - Seal.

Live parts can be accessed if the slot for the relay has been opened.

- Disconnect the pump from the mains power supply before working on it.
- Only operate the pump with a liquid-tight screwed slot for the relay and connector for the relay cable.

1. ➔ Disconnect the pump electrically.
2. ➔ Remove the cover of the slot.
3. ➔ Hold the relay board by the edge of the relay cover.
4. ➔ Carefully insert the relay board into the slot for the relay - the opening in the board in the slot will help with this (A). At the same time make sure that the 3x2 pins on the relay board are sitting correctly and on the left contacts of the 4x2 contact in the slot (B) - see Figure.
5. ➔ Push the relay board into the slot with gentle pressure.
6. ➔ Use the screws to screw the relay cover to the housing until liquid-tight.
7. ➔ Insert the seal connector of the relay cable into the relay cover.
8. ➔ Push the connector onto the pins of the relay cover and then tighten the screw into the connector until liquid-tight.

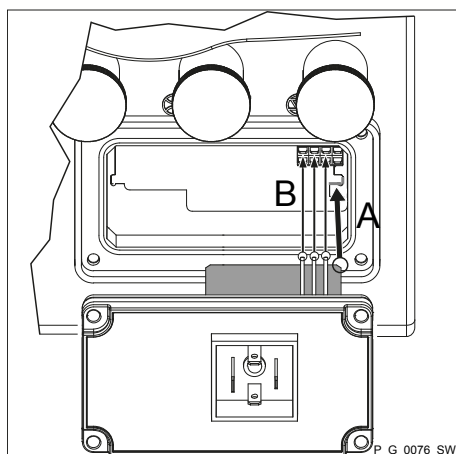

Fig. 36: Slot (B)

27 Index

1, 2, 3 ...	65	Clear counters	70
“External control” terminal	30	Clickwheel	17
2-stage level monitoring	58	Code	70
4 - 20 mA	45	Concentration	47
A		Concentration entry	47
Access code	70	Config I/O	29
Access protection	39, 69	Config-I/Os	55
Acknowledge	73	Configure dosing head	54
Additional information	71, 84	Contact	20, 44
Air in the dosing head		Contact water meter	44
Selective errors	56	Continuous display	17
Selective warning	56	Continuous displays	39, 101
Aligning the connectors differently	23	continuous level monitoring	58
Aligning the dosing head differently	23	Contrast	72
Aligning the hydraulic connectors differently	23	Control elements	17
Aligning the liquid end differently	23	Current output	35
Altitude of site	88	Current volume per revolution	43
Analog	20, 32	Curve	45
Analog input	45	Cycle quantity	55, 57
Analog input iMax		D	
Selective errors	56	Date	43, 59, 71, 84
Analog input iMin		Declaration of Conformity	92, 93
Selective errors	56	Declaration of decontamination	15
Analogue input	31	Decommissioning	85
Analogue output	58	Defective strokes	
Applicable Regulations	93	Selective errors	56
Applied harmonised standards	92	Degassing	
Applied standards	93	Selective errors	56
Assembly	23	Degree of protection	88
AUX	57	Detailed view	71, 84
Auxiliary	55	Diaphragm rupture	
Auxiliary capacity	21, 22, 31, 32, 57	Selective errors	56
Auxiliary frequency	31, 57	Selective warning	56
B		Dimensional drawings	90
Basic principles for setting up the control	37	Direction of rotation	56
Batch	20, 44, 49, 50, 51, 57	Directly changeable variables	73
Bootloader	43	Display	72
Brightness	72	Disposal	85
C		Dosing	57
Calibration	21, 52	Dosing direction	47
Check adjustable variables	73	Dosing head alignment	23
Checking adjustable variables	39	Dosing rate too low	
Cleaning the hose rupture indicator	78	Selective warning	56
Clear	70	Draining the liquid end	85
		E	
		Electrical installation	28

Emergency	13	IP	88
Error	55, 81	K	
Error log book	71	Keys	19
Error processing	46	L	
Events	83	Labels	13
External contact	22, 31	Language	72
External frequency changer	22	LCD screen	17, 72
F		Leakage hole	75
Factor	44	Level	58
Factory setting	72	Selective errors	56
Fault	22, 57	Selective warning	56
FAULT	79	Level switch	21, 32, 34
Fault indicating and pacing relay	21	Linear curve	45
Fault indicating relay	21, 34, 35	Location	59
Fault indicator (red)	21	Lock	69
Fault messages	79	Log book	71, 81, 83
Fault statuses	22	Log book entries	71
Faults without error message	79	Log book entry	71, 84
Functional description	20	Lost in hyperspace	37
Functions	20, 22	Lower side band	46
G		M	
General non-discriminatory approach	2	mA input	31, 45
H		mA-Output	21, 58
Hardware	43	Main display	17
Hemisphere	59	Mains cable	29
Hierarchy of operating modes	22	Maintenance	75
HMI data	43	Manual	20, 22, 44, 47
Hose	70	Material specifications	87
Hose change	76	Maximum metering rate	43
Hose service in	70	Memory	44
I		Memory overflow	
Identification of safety notes	10	Selective errors	56
Identity code	7, 43	Menu	43
Information	43	Metering monitor	32
Information in the event of an emergency	13	Selective warning	56
Initial commissioning	40	Metering volume	57
Input signal mA		Metering volume / Batch	55
Selective errors	56	N	
Inputs/outputs	56	Niveau monitoring	58
Inspection	75	No pressure	
Installation, electrical	28	Selective errors	56
Installation, hydraulic	26	Non-discriminatory approach	2
Intended use	11	Number of revolutions	70
Interval counter	70	O	
Invalid metering vol.		Operating indicator (green)	21
Selective warning	56	Operating menu	96

Operating mode selection	44	Selective errors	56
Operating modes	20, 22	Selective warning	56
Operating overview	94	Semiconductor switch	34, 35
Operation	73	Serial no.	93
Overload		Serial number	43
Selective warning	56	Service	68
Overpressure		Service life of the pump hose	75
Selective errors	56	Set time	59
Overview of equipment	16	Set up, chapter	43
P		Set-up overview	94
Pacing relay	34, 35	Setting	37
Password	39, 70	Setting mode	39
Pause	21, 22, 31, 58	Settings	43
Polarity	57	Side band	45, 46, 47
Pressure too low		Software	43
Selective warning	56	Sound pressure level	14, 88
Priming	21, 22, 73	Spare parts kit	72
Priming time	58	Spare parts kit part number	72
Product type	93	Speed	57
Protection against contact and moisture	88	Start behaviour	55
Protection menu	69	Starting a batch	73
Pulse control	44	Stop	21, 22, 55, 57
Pump active	55, 57	Storage	15
Pump hose	75	Storage period	67
Q		Stroke rate	55
Qualification of personnel	14	Suction lance	21
R		Summertime	59
Rectifying functional faults	79	Sunday	59
Reduction gear system	75	Supplementary information	2
Relay	57	Supply voltage	29
Relay polarity	58	Switch-on counter	43
Relay type	57	Switching-on duration	71, 84
Relays	21, 33	System	54
Relevant directives	92	T	
Repair	76	Technical data, suction lance, continuous	88
Replacing the hose	76	Temperature	71, 84
Replacing the pump hose	76	Selective errors	56
Reversal of direction of rotation	55	Test (function)	22
Revolutions since service	70	Time	43, 71, 84
Revolutions since switching on	71, 84	Timer	57, 59
Room temperature	71, 84	1 time event - several actions	64
S		Action	62
Safety declaration form	15	Actions	68
Scope of delivery	15	Activation	60
Secondary display	17	active	60
Secondary displays	39, 102	active / inactive	67
		Administration functions for commands	61
		Change program lines	65

Check program lines ("Show")	64	Total operating time	43, 71, 84
Clear all	66	Total revolutions	71, 84
Clear individual program lines	65	Transport	15
Clear program lines	65	Tube rupture indicator	33
Clear, all	66	Tube service	59
Clearing the program	66	Turn dosing head	54
Config I/O	29	U	
Creating a program	60	Unpacking	15
Cycle	63	Upper side band	47
Deactivation	60	V	
Delayer	68	Versions	43
Event	62	Viscosity	86
Examples	66	Volume counter	70
Explanation of functions	68	Volume unit	55
Explanation of selected functions	68	W	
Functional faults	67	Warning	55, 57, 83
Generating commands	60	WARNING	81
inactive	60	Warning indicator (amber)	21
Init	63	Warning message	34
Initialisation	68	Warning messages	81
Input	29, 55	Warning sign	10
Inputs	68	Warnings	83
Metering	66		
new program line	61		
Output	29, 55		
Outputs	68		
Pins	29		
Pitfalls	67		
Power supply	67		
Program line	60		
Program line new	61		
Sequence	65		
set	60		
several actions - 1 time event	64		
Show instruction	64		
Show program line	64		
Socket	29		
Sorting criterion	65		
Sorting sequence	65		
Switching time	63		
Time	63		
Time event	62		
Timer information	67		
Trigger	62, 68		
Triggering event	68		
Timer socket	29		
Timer, function	21		
Total metering volume	43		
Total number of revol.	43		



ProMinent GmbH
Im Schuhmachergewann 5-11
69123 Heidelberg
Germany
Telephone: +49 6221 842-0
Fax: +49 6221 842-419
Email: info@prominent.com
Internet: www.prominent.com

981953, 4, en_GB