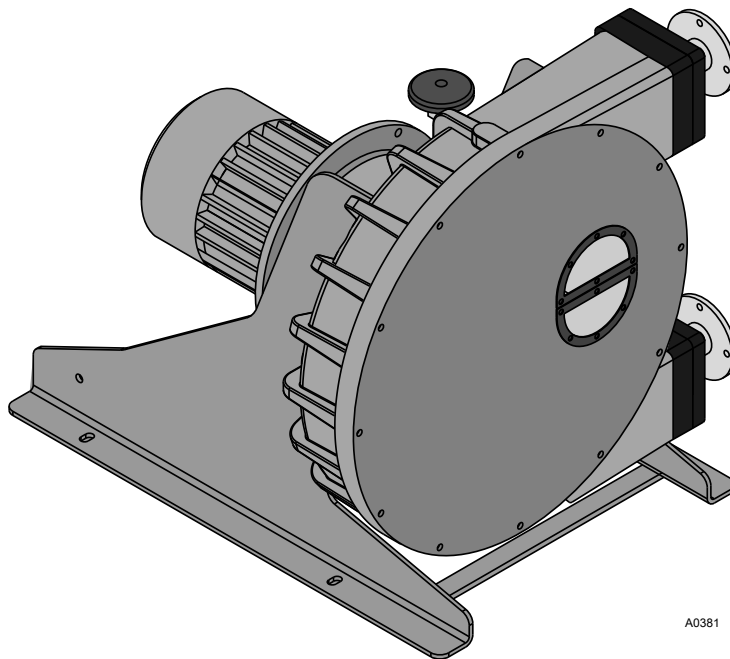

Operating instructions

DULCOflex DFDa

Peristaltic Pump

EN

Please carefully read these operating instructions before use. · Do not discard.
The operator shall be liable for any damage caused by installation or operating errors.
The latest version of the operating instructions are available on our homepage.

General non-discriminatory approach

In order to make it easier to read, this document uses the male form in grammatical structures but with an implied neutral sense. It is aimed equally at both men and women. We kindly ask female readers for their understanding in this simplification of the text.

Supplementary information

Please read the supplementary information in its entirety.

Information



This provides important information relating to the correct operation of the unit or is intended to make your work easier.

Safety Information

The safety information includes detailed descriptions of the hazardous situation, see  *Chapter 1.1 'Explanation of the safety information' on page 4*

The following symbols are used to highlight instructions, links, lists, results and other elements in this document:

Tab. 1: More symbols



Symbol	Description
1. 	Action, step by step
	Outcome of an action
	Links to elements or sections of these instructions or other applicable documents
■	List without set order
[Button]	Display element (e.g. indicators) Operating element (e.g. button, switch)
'Display /GUI'	Screen elements (e.g. buttons, assignment of function keys)
CODE	Presentation of software elements and/or texts

Table of contents

1	Introduction.....	4
1.1	Explanation of the safety information.....	4
1.2	Users' qualifications.....	5
1.3	Identity Code for DULCO®flex DFda 025.....	7
1.4	Identity Code for DULCO®flex DFda 032.....	9
1.5	Identity Code for DULCO®flex DFda 040.....	11
1.6	Identity Code for DULCO®flex DFda 060.....	13
1.7	Identity Code for DULCO®flex DFda 070.....	15
1.8	Identity Code for DULCO®flex DFda 080.....	17
1.9	Identity Code for DULCO®flex DFda 100.....	19
2	Safety and responsibility.....	21
2.1	General safety information.....	21
3	Functional description.....	24
3.1	Overview of the device.....	24
3.2	Construction.....	25
4	Transport, storage, assembly and Installation.....	26
4.1	Transport.....	26
4.2	Storage.....	27
4.3	Assembly.....	28
4.3.1	Ambient conditions.....	28
4.3.2	Alignment of the suction side.....	29
4.3.3	Alignment of the discharge side.....	29
4.3.4	Adjusting the shoe pressure.....	29
4.3.5	Performance curves.....	33
4.3.6	Commissioning.....	36
5	Operating the DFda.....	38
6	Maintenance, repair, troubleshooting, disposal and spare parts.....	39
6.1	Maintenance.....	39
6.2	Exchanging the pump hoses.....	39
6.3	Troubleshooting.....	41
6.4	Disposal of Used Parts.....	42
6.5	Spare parts.....	43
7	DFda Technical Data.....	57
7.1	Dimensions DFda 025.....	58
7.2	Dimensions DFda 032.....	59
7.3	Dimensions DFda 040.....	60
7.4	Dimensions DFda 060.....	61
7.5	Dimensions DFda 070.....	62
7.6	Dimensions DFda 080.....	63
7.7	Dimensions DFda 100.....	64
8	Technical appendices for the DFda.....	65
8.1	EC Declaration of Conformity for Machinery.....	65
9	Index.....	66

1 Introduction

These operating instructions provide information on the technical data and functions of the DULCO®flex peristaltic pump from the DFDA product range.

1.1 Explanation of the safety information

Introduction

These operating instructions provide information on the technical data and functions of the product. These operating instructions provide detailed safety information and are provided as clear step-by-step instructions.

The safety information and notes are categorised according to the following scheme. A number of different symbols are used to denote different situations. The symbols shown here serve only as examples.



DANGER!

Nature and source of the danger

Consequence: Fatal or very serious injuries.

Measure to be taken to avoid this danger

Danger!

- Denotes an immediate threatening danger. If this is disregarded, it will result in fatal or very serious injuries.



WARNING!

Nature and source of the danger

Possible consequence: Fatal or very serious injuries.

Measure to be taken to avoid this danger

Warning!

- Denotes a possibly hazardous situation. If this is disregarded, it could result in fatal or very serious injuries.



CAUTION!

Nature and source of the danger

Possible consequence: Slight or minor injuries, material damage.

Measure to be taken to avoid this danger

Caution!

- Denotes a possibly hazardous situation. If this is disregarded, it could result in slight or minor injuries. May also be used as a warning about material damage.

**NOTICE!****Nature and source of the danger**

Damage to the product or its surroundings

Measure to be taken to avoid this danger

Note!

- Denotes a possibly damaging situation. If this is disregarded, the product or an object in its vicinity could be damaged.

**Type of information**

Hints on use and additional information

Source of the information, additional measures

Information!

- *Denotes hints on use and other useful information. It does not indicate a hazardous or damaging situation.*

1.2 Users' qualifications

**WARNING!**

Danger of injury with inadequately qualified personnel!

The operator of the plant / device is responsible for ensuring that the qualifications are fulfilled.

If inadequately qualified personnel work on the unit or loiter in the hazard zone of the unit, this could result in dangers that could cause serious injuries and material damage.

- All work on the unit should therefore only be conducted by qualified personnel.
- Unqualified personnel should be kept away from the hazard zone

Training	Definition
Instructed personnel	An instructed person is deemed to be a person who has been instructed and, if required, trained in the tasks assigned to him/her and possible dangers that could result from improper behaviour, as well as having been instructed in the required protective equipment and protective measures.
Trained user	A trained user is a person who fulfils the requirements made of an instructed person and who has also received additional training specific to the system from ProMinent or another authorised distribution partner.
Trained qualified personnel	A qualified employee is deemed to be a person who is able to assess the tasks assigned to him and recognize possible hazards based on his/her training, knowledge and experience, as well as knowledge of pertinent regulations. The assessment of a person's technical training can also be based on several years of work in the relevant field.

Training	Definition
Electrician	<p>Electricians are deemed to be people, who are able to complete work on electrical systems and recognize and avoid possible hazards independently based on his/her technical training and experience, as well as knowledge of pertinent standards and regulations.</p> <p>Electricians should be specifically trained for the working environment in which they are employed and know the relevant standards and regulations.</p> <p>Electricians must comply with the provisions of the applicable statutory directives on accident prevention.</p>
Customer Service department	Customer Service department refers to service technicians, who have received proven training and have been authorised by ProMinent to work on the system.



Note for the system operator

The pertinent accident prevention regulations, as well as all other generally acknowledged safety regulations, must be adhered to!

1.3 Identity Code for DULCO®flex DFDa 025

Identity code	
DFDa	DULCO®flex DFDa 025
	Type
025	DFDa 025, 0.3 l/revolution
	Power end/drive
000	Pump without power end/drive
	Reduction gear system / 3 x 230 / 400 VAC
A11	0.55 kW, 18 rpm, 324 l/h, 15 bar
A12	0.75 kW, 28 rpm, 504 l/h, 15 bar
A13	0.75 kW, 39 rpm, 702 l/h, 10 bar
A14	0.75 kW, 45 rpm, 810 l/h, 5 bar
A15	1.10 kW, 55 rpm, 990 l/h, 5 bar
	Gear motor with integrated frequency converter / 1x 230 VAC
A31	1.10 kW, 16 ... 55 rpm, 288 ... 990 l/h, 20 ... 70 Hz, 5 bar
A32	1.50 kW, 18 ... 63 rpm, 324 ... 1134 l/h, 20 ... 70 Hz, 5 bar
	Gear motor (external frequency converter required) / 3 x 230 / 400 VAC
A41	0.75 kW, 4 ... 36 rpm, 72 ... 648 l/h, 7 ... 65 Hz, 15 bar
A42	1.10 kW, 6 ... 58 rpm, 108 ... 1044 l/h, 7 ... 65 Hz, 5 bar
A43	1.50 kW, 9 ... 86 rpm, 162 ... 1548 l/h, 7 ... 65 Hz, 5 bar
	Hose material
0	NR
B	NBR
E	EPDM
	Hydraulic connector
I	DIN flange, VA, DN25
J	DIN flange, PP, DN25
K	DIN flange PVDF/PTFE, DN25
L	ANSI flange, VA, 1"
	Base plate
0	Base plate, lacquered steel
1	Base plate, stainless steel
2	Portable unit + lacquered steel base plate
3	Portable unit + stainless steel base plate
	Leakage sensor
0	without leakage sensor
L	with leakage sensor
M	with leakage sensor + relay output

Identity code										
DFDa	DULCO®flex DFDa 025									
										Rotor
									0	Rotor with 2 shoes
										Batch control
									0	No batch control
										Special version
									0	Standard
									H	Housing, Halar® coated
										Vacuum system
									0	none
									V	with vacuum system
										Approvals
									01	CE mark

1.4 Identity Code for DULCO®flex DFDa 032

Identity code	
DFDa	DULCO®flex DFDa 032
	Type
032	DFDa 032, 0.625 l/revolution
	Power end/drive
000	Pump without power end/drive
	Reduction gear system / 3 x 230 / 400 VAC
B11	0.75 kW, 21 rpm, 787 l/h, 10 bar
B12	1.10 kW, 21 rpm, 787 l/h, 15 bar
B13	1.10 kW, 30 rpm, 1125 l/h, 10 bar
B14	1.10 kW, 38 rpm, 1425 l/h, 10 bar
B15	1.50 kW, 47 rpm, 1762 l/h, 5 bar
B16	1.50 kW, 58 rpm, 2175 l/h, 5 bar
	Gear motor with integrated frequency converter / 1x 230 VAC
B31	1.50 kW, 12 ... 42 rpm, 450 ... 1575 l/h, 20 ... 70 Hz, 7.5 bar
B32	2.20 kW, 19 ... 66 rpm, 712 ... 2475 l/h, 20 ... 70 Hz, 5 bar
	Gear motor (external frequency converter required) / 3 x 230 / 400 VAC
B41	1.10 kW, 4 ... 39 rpm, 150 ... 1462 l/h, 7 ... 65 Hz, 7.5 bar
B42	1.50 kW, 5 ... 49 rpm, 190 ... 1837 l/h, 7 ... 65 Hz, 7.5 bar
B43	2.20 kW, 8 ... 75 rpm, 300 ... 2812 l/h, 7 ... 65 Hz, 5 bar
	Hose material
0	NR
B	NBR
E	EPDM
	Hydraulic connector
I	DIN flange VA DN32
J	DIN flange, PP, DN32
K	DIN flange, PVDF/PTFE, DN32
L	ANSI flange, VA, 1 1/4"
	Base plate
0	Base plate, lacquered steel
1	Base plate, stainless steel
2	Portable unit + lacquered steel base plate
3	Portable unit + stainless steel base plate
	Leakage sensor
0	without leakage sensor
L	with leakage sensor

Identity code									
DFDa	DULCO®flex DFDa 032								
							M	with leakage sensor + relay output	
								Rotor	
							0	Rotor with 2 shoes	
								Batch control	
							0	No batch control	
								Special version	
							0	Standard	
							H	Housing, Halar® coated	
								Vacuum system	
							0	none	
							V	with vacuum system	
								Approvals	
							01	CE mark	

1.5 Identity Code for DULCO®flex DFDa 040

Identity code	
DFDa	DULCO®flex DFDa 040
	Type
040	DFDa 040, 1.33 l/revolution
	Power end/drive
000	Pump without power end/drive
	Reduction gear system / 3 x 230 / 400 VAC
C11	1.10 kW, 21 rpm, 1676 l/h, 10 bar
C12	1.10 kW, 26 rpm, 2075 l/h, 7.5 bar
C13	1.50 kW, 21 rpm, 1676 l/h, 10 bar
C14	1.50 kW, 26 rpm, 2075 l/h, 15 bar
C15	1.50 kW, 38 rpm, 3032 l/h, 7.5 bar
C16	1.50 kW, 43 rpm, 3431 l/h, 5 bar
C17	2.2 kW, 48 rpm, 3830 l/h, 5 bar
	Gear motor with integrated frequency converter / 1x 230 VAC
C31	2.20 kW, 17 ... 60 rpm, 1356 ... 4788 l/h, 20 ... 70 Hz, 5 bar
	Gear motor (external frequency converter required) / 3 x 230 / 400 VAC
C41	1.50 kW, 4 ... 34 rpm, 320 ... 2713 l/h, 7 ... 65 Hz, 5 bar
C42	2.20 kW, 4 ... 34 rpm, 320 ... 2713 l/h, 7 ... 65 Hz, 10 bar
C43	2.20 kW, 5 ... 49 rpm, 400 ... 3910 l/h, 7 ... 65 Hz, 5 bar
C44	3.00 kW, 7 ... 62 rpm, 558 ... 4948 l/h, 7 ... 64 Hz, 5 bar
	Hose material
0	NR
B	NBR
E	EPDM
	Hydraulic connector
I	DIN flange VA DN40
J	DIN flange PP DN40
K	DIN flange, PVDF, DN40
L	ANSI flange, VA, 1 1/2"
M	ANSI flange, PP 1 1/2"
N	ANSI flange, PVDF/PTFE, 1 1/2"
	Base plate
0	Base plate, lacquered steel
1	Base plate, stainless steel
2	Portable unit + lacquered steel base plate
3	Portable unit + stainless steel base plate

Identity code	
DFDa	DULCO®flex DFDa 040
	Leakage sensor
0	without leakage sensor
L	with leakage sensor
M	with leakage sensor + relay output
	Rotor
0	Rotor with 2 shoes
	Batch control
0	No batch control
	Special version
0	Standard
H	Housing, Halar® coated
	Vacuum system
0	none
V	with vacuum system
	Approvals
01	CE mark

1.6 Identity Code for DULCO®flex DFDa 060

Identity code	
DFDa	DULCO®flex DFDa 060
	Type
060	DFDa 060, 2.9 l/revolution
	Power end/drive
000	Pump without power end/drive
	Reduction gear system / 3 x 230 / 400 VAC
D11	2.20 kW, 22 rpm, 3.8 m³/h, 5 bar
D12	3.00 kW, 26 rpm, 4.5 m³/h, 5 bar
D13	4.00 kW, 22 rpm, 3.8 m³/h, 15 bar
D14	4.00 kW, 26 rpm, 4.5 m³/h, 10 bar
D15	4.00 kW, 32 rpm, 5.6 m³/h, 5 bar
D16	4.00 kW, 37 rpm, 6.4 m³/h, 5 bar
D17	5.50 kW, 47 rpm, 8.2 m³/h, 5 bar
	Gear motor with integrated frequency converter / 1x 230 VAC
D31	5.50 kW, 10 ... 36 rpm, 1.7 ... 6.3 m³/h, 20 ... 70 Hz, 5 bar
D32	7.50 kW, 19 ... 66 rpm, 3.3 ... 11.5 m³/h, 20 ... 70 Hz, 5 bar
	Gear motor (external frequency converter required) / 3x 230/400 VAC
D41	5.50 kW, 4... 34 rpm, 0.7 ... 5.9 m³/h, 20 ... 70 Hz, 5 bar
D42	7.50 kW, 7 ... 61 rpm, 1.2 ... 10.6 m³/h, 20 ... 70 Hz, 5 bar
	Hose material
0	NR
B	NBR
E	EPDM
	Hydraulic connector
I	DIN Flange, VA, DN50
L	ANSI flange, VA, 2"
J	DIN flange, PP, DN50
M	ANSI flange, PP, 2"
U	DIN flange, VA, Halar® coated, DN50
V	ANSI flange, VA, Halar® coated, 2"
	Base plate
0	Base plate, lacquered steel
1	Base plate, stainless steel
2	Portable unit + lacquered steel base plate
	Leakage sensor
0	without leakage sensor

Identity code										
DFDa	DULCO®flex DFDa 060									
							L	with leakage sensor		
							M	with leakage sensor + relay output		
								Rotor		
							0	Rotor with 2 shoes		
								Batch control		
							0	No batch control		
								Special version		
							0	Standard		
							H	Housing, Halar® coated		
								Vacuum system		
							0	none		
							V	with vacuum system		
								Approvals		
							01	CE mark		

1.7 Identity Code for DULCO®flex DFDa 070

Identity code	
DFDa	DULCO®flex DFDa 070
	Type
070	DFDa 070, 6.70 l/revolution
	Power end/drive
000	Pump without power end/drive
	Reduction gear system / 3 x 230 / 400 VAC
E11	3.00 kW, 13.5 rpm, 5.4 m³/h, 5 bar
E12	4.0 kW, 18 rpm, 7.2 m³/h, 7.5 bar
E13	5.5 kW, 13.5 rpm, 5.4 m³/h, 15 bar
E14	5.5 kW, 26 rpm, 10.4 m³/h, 5 bar
E15	7.5 kW, 18 rpm, 7.2 m³/h, 15 bar
E16	7.5 kW, 26 rpm, 10.4 m³/h, 10 bar
E17	7.5 kW, 32 rpm, 12.8 m³/h, 7.5 bar
E18	7.5 kW, 40 rpm, 16.0 m³/h, 5 bar
	Gear motor with integrated frequency converter / 1x 230 VAC
E31	7.5 kW, 10 ... 36 rpm, 4.0 ... 14.4 m³/h, 20 ... 70 Hz, 5 bar
	Gear motor (external frequency converter required) / 3x 230/400 VAC
E41	7.5 kW, 4 ... 34 rpm, 1.6 ... 13.7 m³/h, 7 ... 65 Hz, 5 bar
	Hose material
0	NR
B	NBR
E	EPDM
	Hydraulic connector
I	DIN flange VA, DN65
J	DIN flange PP, DN65
L	ANSI flange, VA, 2 1/2"
M	ANSI flange, PP 2 1/2"
Q	DIN flange, VA, Halar® coated, DN65
R	ANSI flange, VA, Halar® coated, 2 1/2"
	Base plate
0	Base plate, lacquered steel
1	Base plate, stainless steel
	Leakage sensor
0	without leakage sensor
L	with leakage sensor
M	with leakage sensor + relay output

Identity code									
DFDa	DULCO®flex DFDa 070								
									Rotor
								0	Rotor with 2 shoes
									Batch control
								0	No batch control
									Special version
								0	Standard
								H	Housing, Halar® coated
									Vacuum system
								0	none
								V	with vacuum system
									Approvals
								01	CE mark

1.8 Identity Code for DULCO®flex DFDa 080

Identity code	
DFDa	DULCO®flex DFDa 080
	Type
080	DFDa 080, 11.70 l/revolution
	Power end/drive
000	Pump without power end/drive
	Reduction gear system / 3 x 230 / 400 VAC
G11	4.00 kW, 12.5 rpm, 8.7 m³/h, 5 bar
G12	5.5 kW, 17.6 rpm, 12.3 m³/h, 5 bar
G13	7.5 kW, 12.5 rpm, 8.7 m³/h, 15 bar
G14	7.5 kW, 17.6 rpm, 12.3 m³/h, 10 bar
G15	7.5 kW, 20 rpm, 14.0 m³/h, 7.5 bar
G16	7.5 kW, 27.7 rpm, 19.4 m³/h, 5 bar
G17	11 kW, 30 rpm, 21.0 m³/h, 5 bar
	Hose material
0	NR
B	NBR
E	EPDM
	Hydraulic connector
I	DIN Flange, VA, DN80
J	DIN flange, PP, DN80
L	ANSI flange, VA, 3"
M	ANSI flange, PP, 3"
Q	DIN flange, VA, Halar® coated, DN80
R	ANSI flange, VA, Halar® coated, 3"
	Base plate
0	Base plate, lacquered steel
	Leakage sensor
0	without leakage sensor
L	with leakage sensor
M	with leakage sensor + relay output
	Rotor
0	Rotor with 2 shoes
	Batch control
0	No batch control
	Special version
0	Standard

Identity code											
DFDa	DULCO®flex DFDa 080										
										Vacuum system	
										0	none
										V	with vacuum system
											Approvals
										01	CE mark

1.9 Identity Code for DULCO®flex DFDa 100

Identity code	
DFDa	DULCO®flex DFDa 100
	Type
100	DFDa 100, 20.0 l/revolution
	Power end/drive
000	Pump without power end/drive
	Reduction gear system / 3 x 230 / 400 VAC
F11	7.5 kW, 12.0 rpm, 14.4 m ³ /h, 5 bar
F12	11.0 kW, 18.0 rpm, 21.6 m ³ /h, 5 bar
F13	15.0 kW, 12.0 rpm, 14.4 m ³ /h, 15 bar
F14	15.0 kW, 18.0 rpm, 21.6 m ³ /h, 10 bar
F15	15.0 kW, 23.0 rpm, 27.6 m ³ /h, 7.5 bar
F16	15.0 kW, 28.0 rpm, 33.6 m ³ /h, 5 bar
F17	18.5 kW, 30.0 rpm, 36.0 m ³ /h, 5 bar
	Hose material
0	NR
B	NBR
E	EPDM
	Hydraulic connector
I	DIN flange, VA, DN100
J	DIN flange, PP, DN100
L	ANSI flange, VA, 4"
M	ANSI flange, PP, 4"
Q	DIN flange, VA, Halar® coated, DN100
R	ANSI flange, VA, Halar® coated, 4"
	Base plate
0	Base plate, lacquered steel
	Leakage sensor
0	without leakage sensor
L	with leakage sensor
M	with leakage sensor + relay output
	Rotor
0	Rotor with 2 shoes
	Batch control
0	No batch control
	Special version
0	Standard

Identity code											
DFDa	DULCO®flex DFDa 100										
										Vacuum system	
										0	none
										V	with vacuum system
											Approvals
										01	CE mark

2 Safety and responsibility

2.1 General safety information

**WARNING!****Live parts**

Possible consequence: Fatal or very serious injuries

- Measure: The device must be disconnected from the power supply before it is opened
- Isolate damaged, faulty or manipulated devices from the mains in order to de-energise.

**WARNING!****Emergency stop switch**

Possible consequence: Fatal or very serious injuries

An emergency stop switch is to be connected for the entire plant. This should enable the entire plant to be shut down in the event of an emergency in such a way that the overall plant can be brought into a safe condition.

**WARNING!****Unauthorised access**

Possible consequence: Fatal or very serious injuries

- Measure: Ensure that there can be no unauthorised access to the unit

**WARNING!****Hazardous media / contamination of persons and equipment**

Possible consequence: Fatal or very serious injuries, material damage

- Ensure that the pump hoses are resistance against the media being conveyed
- Always observe the the safety data sheets for the media to be conveyed. The system operator must ensure that these safety data sheets are available and that they are kept up-to-date
- The safety data sheets for the media being conveyed are always decisive for initiating counter measures in the event of leakage to the media being conveyed
- Observe the general restrictions in relation to viscosity limits, chemical resistance and density
- Always switch the pump off before exchanging the pump hose



WARNING!

Correct and proper use

Possible consequence: Fatal or very serious injuries

- The unit is not intended to convey or regulate gaseous or solid media
- Do not exceed the rated pressure, speed or temperature for the pump
- The unit may only be used in accordance with the technical data and specifications provided in these operating instructions and in the operating instructions for the individual components
- The system is not designed for use in areas at risk from explosion
- Only switch the pump on if it has been properly fastened to the floor
- Only switch the pump on if it the front cover has been attached.



WARNING!

Operational lifetime of the pump hoses

Possible consequence: Fatal or very serious injuries

The operational lifetime of the pump hoses cannot be precisely specified. For this reason, the possibility of fracture and consequential leakage of liquids must be accounted for. If the hose rupture alarm (optional) is fitted, then the pump can be stopped and / or an electrical valve can be actuated.

In addition, you must avoid particles from untight hoses being introduced into the media being conveyed. This can be achieved e.g. by means of filtration, a hose rupture alarm or other means suitable for the respective process.



CAUTION!

CIP cleaning

In the event of CIP cleaning, it is necessary to obtain information from the manufacturer about correct installation of the pump (a special installation is required), as well as regarding the compatibility of the cleaning agents with the pump hoses of the pump and the other hydraulic connections.

Cleaning should be undertaken at the recommended maximum temperature.



CAUTION!

Direction of rotation / flow direction

Possible consequence: Material damage right through to destruction of the unit

- The pump's direction of rotation in relation to the desired flow direction must be checked prior to every start.



CAUTION!

Environmental influences

Possible consequence: Material damage right through to destruction of the unit

- The device is not suitable for outdoor operation
- Take suitable measures to protect the device from environmental influences such as:
 - UV rays
 - Moisture
 - Frost, etc.

3 Functional description

Brief functional description

The package contents supplied with the DULCO®flex DFDa is selectable via the identcode.

The DULCO®flex DFDa is a displacement pump. The feed chemical is transported by the rotor squeezing the hose in the direction of flow. No valves are needed for this. This ensures gentle handling of the metered media.

The DULCO®flex DFDa has been designed for safe and uncomplicated operation, as well as straightforward maintenance.

The DULCO®flex DFDa can be used for many different media. However, this pump type is often the optimal solution for abrasive, shear-sensitive and viscous media.

Typical areas of use include processes where only a low discharge pressure is required of up to 15 bar.

3.1 Overview of the device

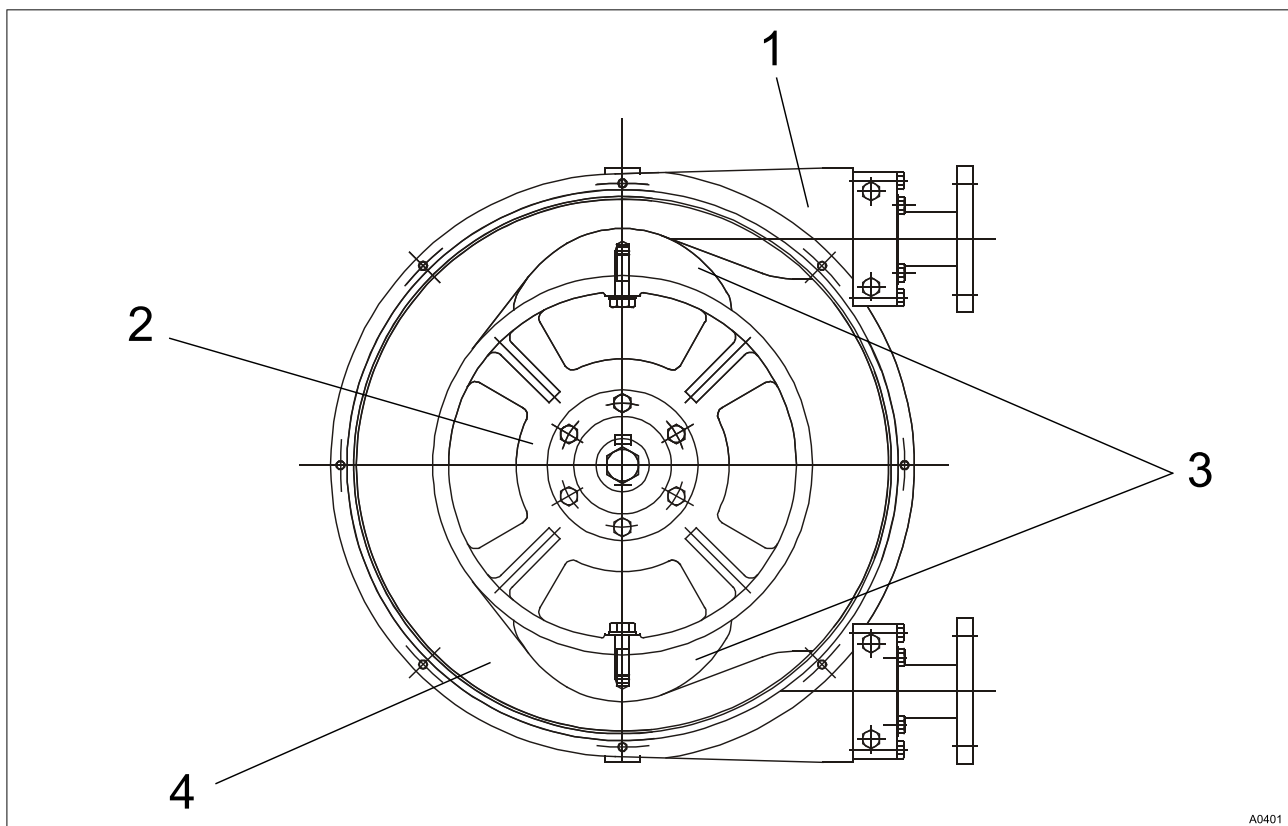

Fig. 1: Functional principle

- 1 Housing
- 2 Rotor
- 3 Shoes
- 4 Hose

3.2 Construction

Main modules:

- Drive Unit
- Housing
- Base frame

The pump housing is closed off with a screwed front cover in order to avoid the risk of injury.

The motor serves to drive the rotor. Two shoes at the ends of the rotor serve to press the pump hose against the pump housing.

The rotary movement of the rotors alternately press and relax the shoes in relation to the pump hose. This serves to suck the media in and convey it into the metering line.

4 Transport, storage, assembly and Installation

- **User qualification, transport and storage:** trained user, see [Chapter 1.2 'Users' qualifications' on page 5](#)
- **User qualification, installation:** trained qualified personnel, see [Chapter 1.2 'Users' qualifications' on page 5](#)
- **User qualification, electrical installation:** Electrical technician, see [Chapter 1.2 'Users' qualifications' on page 5](#)



WARNING!

Danger from hazardous substances!

Possible consequence: Fatal or very serious injuries.

Please ensure when handling hazardous substances that you have read the latest safety data sheets provided by the manufacture of the hazardous substance. The actions required are described in the safety data sheet. Check the safety data sheet regularly and replace, if necessary, as the hazard potential of a substance can be re-evaluated at any time based on new findings.

The system operator is responsible for ensuring that these safety data sheets are available and that they are kept up to date, as well as for producing an associated hazard assessment for the workstations affected.

4.1 Transport

Transport

- The pump is protected by cardboard packaging
- The packaging materials can be recycled
- For ambient conditions for storage and transportation see [Chapter 4.3.1 'Ambient conditions' on page 28](#)



WARNING!

Never stand under suspended loads.

Possible consequence: Fatal or very serious injuries

- Walking or standing under suspended loads is prohibited
- Secure the peristaltic pump when lifting and transporting it to ensure that it cannot slip or topple.
- Use suitable and approved lifting equipment. Observe the information given in the data sheets for the lifting equipment

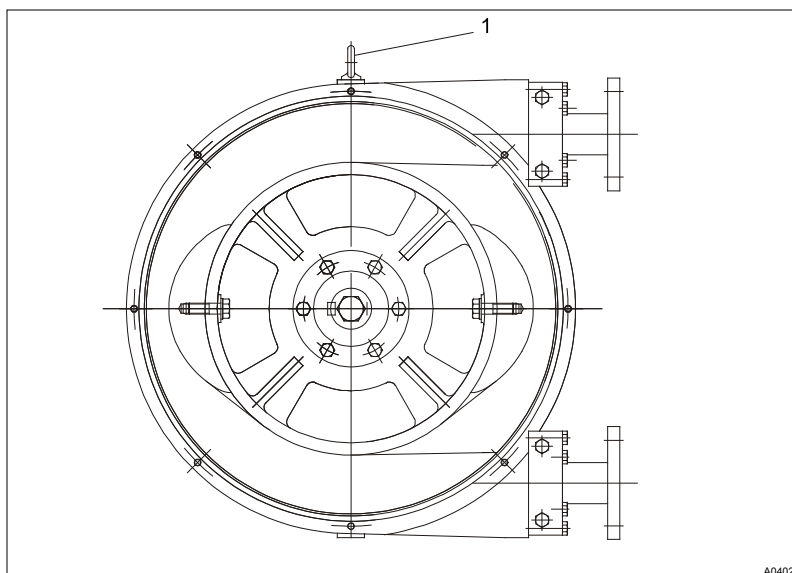

Fig. 2: Lifting the DFda 025 / 032 / 040

1 Lifting lug

The lifting lugs (1) on the pump housing are used to lift the DFda 025 / 032 / 040.

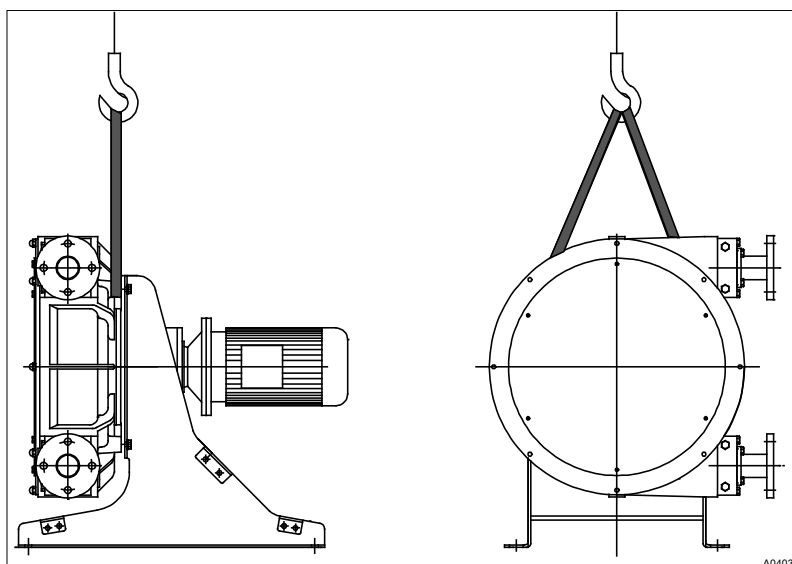

Fig. 3: Lifting the DFda 060 / 070 / 080 / 100

Appropriate lifting equipment is used to lift the DFda 060 / 070 / 080 / 100, as shown in Fig. 3.

4.2 Storage

Storage

- The pump hose should be removed from the housing during the period of storage
- For storage durations longer than 60 days, the coupling surfaces (terminals, reducing adaptors, motors) are to be protected with suitable antioxidant agents
- For environmental conditions for storage and transportation see [Chapter 4.3.1 'Ambient conditions' on page 28](#)

4.3 Assembly



CAUTION!

Possible consequence: Slight or minor injuries.
Material damage.

Carry out assembly work before commencing the electrical installation.

Observe the permissible ambient conditions.

4.3.1 Ambient conditions



NOTICE!

Ambient conditions

Possible consequence: Property damage and increased wear and tear

Assembly is to be carried out in the following order. If the must has to be installed outdoors, then it is to be equipped with protection against sunlight and weather influences.

When positioning the pump, ensure that sufficient room for access is provided for all types of maintenance work.

There are limit values for temperature and pressure, depending on the type of hose selected. These limit values are described in the following section:

Tab. 2: Limit values for hose temperature and pressure

Material Hose	min. temp. (°C)		max. temp. (°C)		max. pressure (bar)
	Feed chemical	Environment	Feed chemical	Environment	
NR	-20	-40	80*	-40	15
NBR	-10	-40	80*	-40	15
EPDM	-10	-40	80*	-40	15
NR-A	-10	-40	80*	-40	15
NBR-A	-10	-40	80*	-40	15

* at high temperatures, the life of the hose can be drastically reduced. Please contact in the event of temperatures higher than 50 ° C the manufacturer of the pump.

Also observe the general safety information, see  Chapter 2.1 'General safety information' on page 21

4.3.2 Alignment of the suction side

The pump is to be positioned as near as possible to the liquid container, so that the suction side is kept as short and straight as possible.

The suction line must be absolutely airtight and made of a suitable material, so that it is not squeezed together under vacuum.

The diameter must correspond to the rated diameter of the pump hose. A larger diameter is recommended in the event of viscose liquids.

The pump is self-priming and does not require an admission valve. The pump is reversible and the suction connection can therefore comprise of one of two options. Normally the option is selected which is best suited to the physical conditions of the installation.

It is recommended to use a flexible transition between two fixed pipes and the hydraulic connection of the pump, in order to avoid the transmission of vibrations.

4.3.3 Alignment of the discharge side

The discharge line is to be kept as straight and short as possible, in order to avoid performance reduction.

The diameter must correspond to the rated diameter of the pump hose. Bei viskosen Flüssigkeiten wird ein größerer Durchmesser empfohlen.

It is recommended to use a flexible transition between two fixed pipes and the hydraulic connection of the pump, in order to avoid the transmission of vibrations.

4.3.4 Adjusting the shoe pressure

The peristaltic pump is equipped with spacer plates (7), which are used to adjust the precise pressure distance of the shoes (5) (depending on the speed and operating pressure).

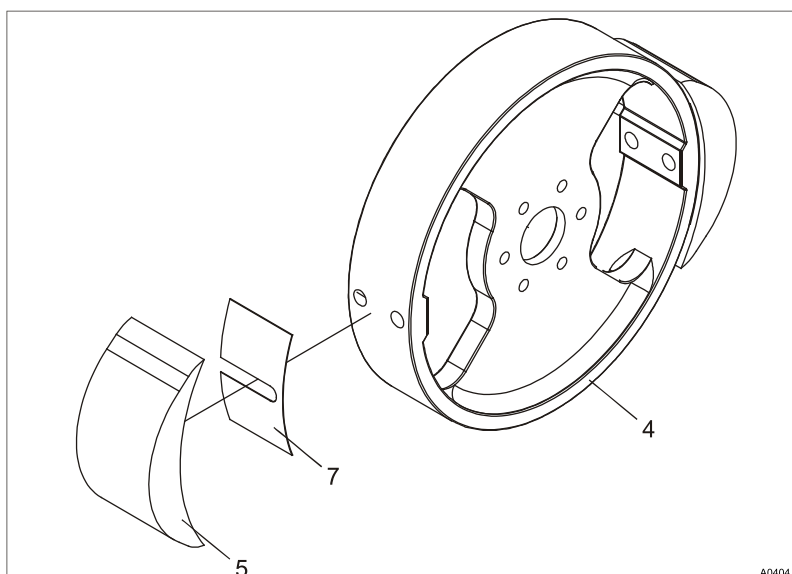

Fig. 4: Spacer plates / shoes

- 4 Rotor
- 5 Shoes
- 7 Spacer plates

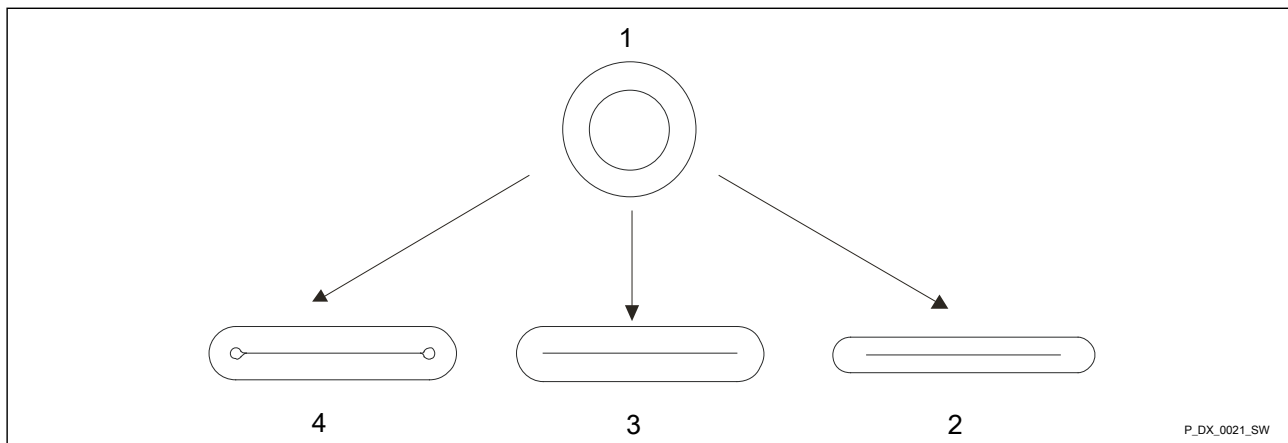

Fig. 5: Squeezing the hose

- 1 Normal shape of hose
- 2 Excessive squeezing (increased wear and tear on the pump and hose)
- 3 Perfect squeezing
- 4 Insufficient squeezing (medium backflowing in the cavity will destroy the hose within a short period of time)

The spacer plates are factory-fitted. You can adapt the number of spacer plates to the actual operating conditions in accordance with the following table.

Tab. 3: DFDa 025 / Number of spacer plates:

rpm	0 ... 19	20 ... 39	40 ... 59	60 ... 79	80 ... 99
0.5	1	1	1	0	0
2.5	1	1	1	1	1
5.0 *	2	2	2	2	2
7.5	4	3	3	3	3
10.0	5	4	4	4	4
12.5	6	5	5	5	4
15.0	7	6	6	6	-

* Delivered state

Tab. 4: DFDa 032 / Number of spacer plates:

rpm	0 ... 19	20 ... 39	40 ... 59	60 ... 79	80 ... 99
bar					
0.5	0	0	0	0	0
2.5	0	0	0	0	0
5.0 *	1	1	1	0	0
7.5	2	1	1	1	0
10.0	2	2	2	1	1
12.5	3	3	3	2	2
15.0	4	4	4	3	-

* Delivered state

Tab. 5: DFDa 040 / Number of spacer plates:

rpm	0 ... 19	20 ... 39	40 ... 59	60 ... 79	80 ... 99
bar					
0.5	3	3	2	2	2
2.5	4	3	3	3	-
5.0*	5	4	4	4	-
7.5	5	5	5	-	-
10.0	6	6	5	-	-
12.5	7	7	6	-	-
15.0	8	8	-	-	-

* Delivered state

Tab. 6: DFDa 060 / Number of spacer plates:

rpm	0 ... 19	20 ... 39	40 ... 59	60 ... 79	80 ... 99
bar					
0.5	0	0	0	0	0
2.5	0	0	0	0	0
5.0*	1	1	0	0	0
7.5	1	1	1	1	1
10.0	2	2	1	1	-
12.5	2	2	2	2	-
15.0	2	2	2	-	-

* Delivered state

Tab. 7: DFDa 070 / Number of spacer plates:

rpm	0 ... 19	20 ... 39	40 ... 59	60 ... 79	80 ... 99
bar					
0.5	3	2	1	0	0
2.5	4	3	2	1	0
5.0*	6	5	4	3	-
7.5	7	6	5	-	-
10.0	9	8	7	-	-
12.5	10	9	8	-	-
15.0	12	11	-	-	-

* Delivered state

Tab. 8: DFDa 080 / Number of spacer plates:

rpm	0 ... 19	20 ... 39	40 ... 59	60 ... 79	80 ... 99
bar					
0.5	1	1	-	-	-
2.5	1	2	-	-	-
5.0*	2	2	-	-	-
7.5	2	2	-	-	-
10.0	3	3	-	-	-
12.5	4	-	-	-	-
15.0	4	-	-	-	-

* Delivered state

Tab. 9: DFDa 100 / Number of spacer plates:

rpm	0 ... 19	20 ... 39	40 ... 59	60 ... 79	80 ... 99
bar					
0.5	1	1	-	-	-
2.5	1	1	-	-	-
5.0*	2	2	-	-	-
7.5	2	2	-	-	-
10.0	3	2	-	-	-
12.5	3	-	-	-	-
15.0	4	-	-	-	-

* Delivered state

4.3.5 Performance curves



NOTICE!

Maximum pressure under continuous operation

The lines indicate the limit for maximum pressure under continuous operation

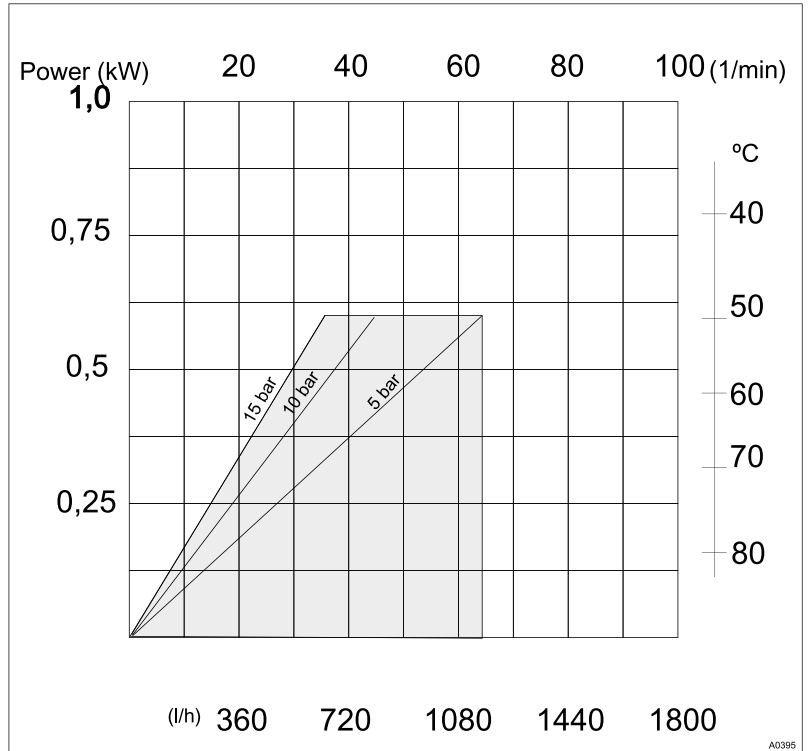

Fig. 6: DFDa 025

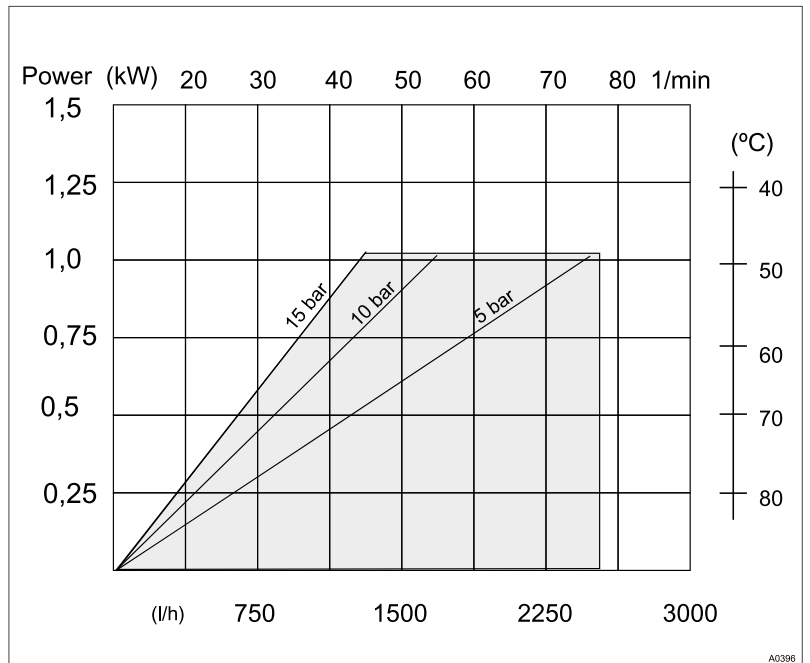

Fig. 7: DFDa 032

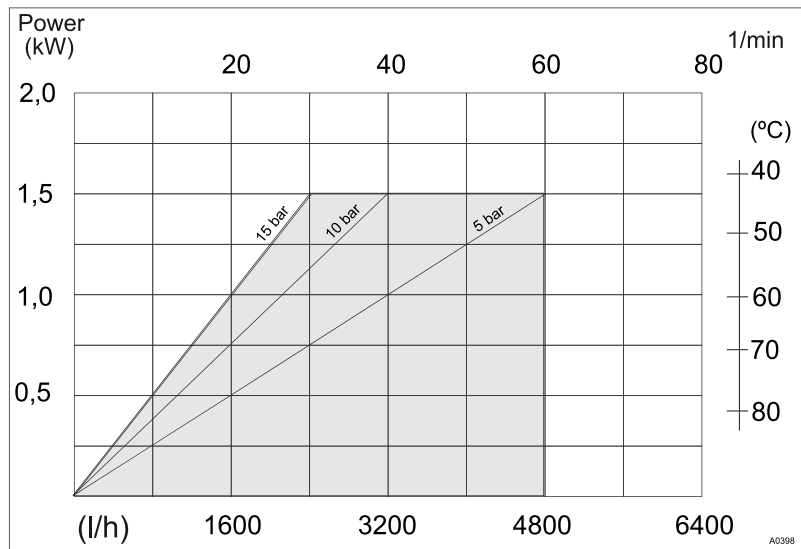

Fig. 8: DFDa 040

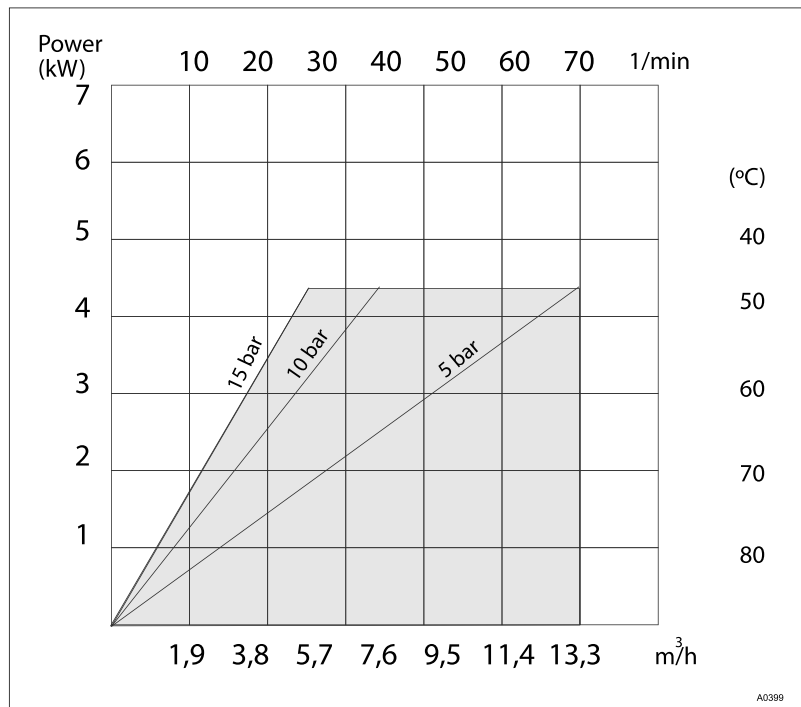

Fig. 9: DFDa 060

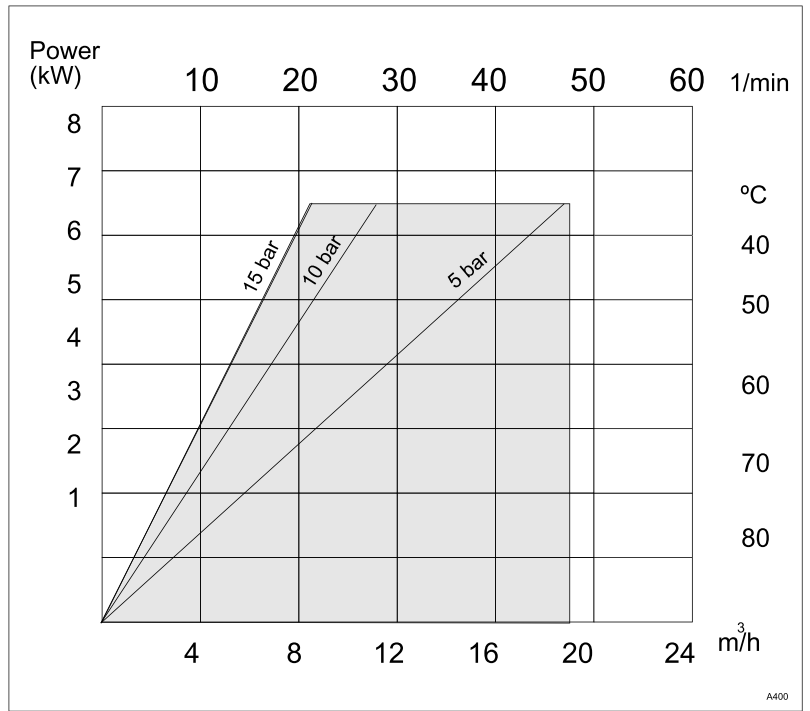

Fig. 10: DFDa 070

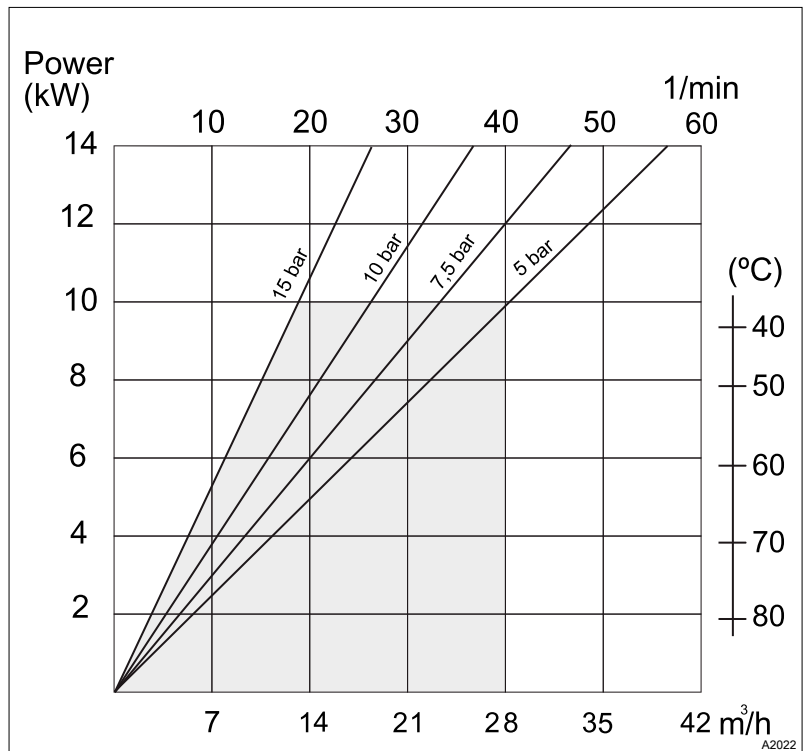

Fig. 11: DFDa 080

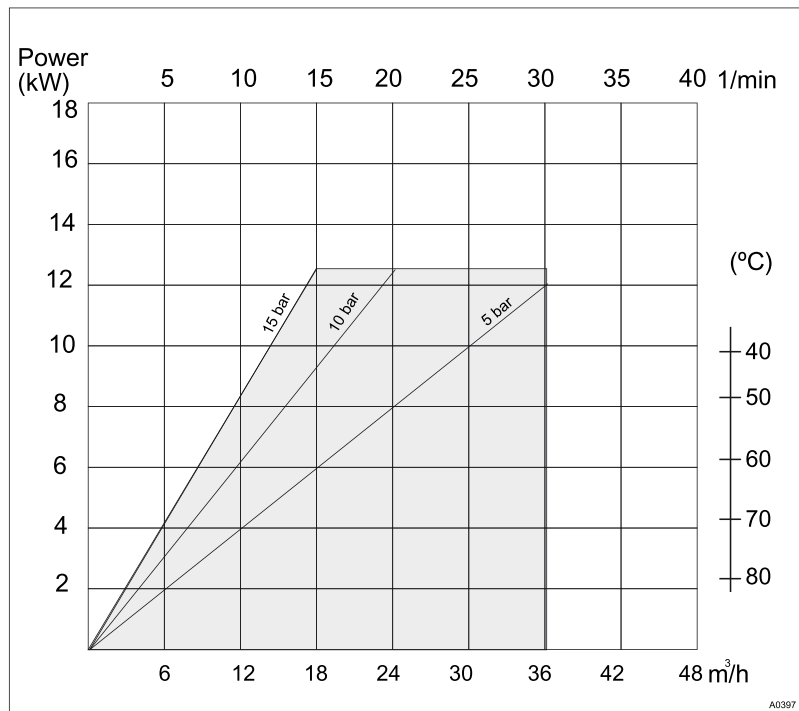

Fig. 12: DFDa 100

4.3.6 Commissioning

- **User qualification, commissioning:** trained user, see [Chapter 1.2 'Users' qualifications'](#) on page 5

4.3.6.1 Testing prior to commissioning the pump

The following tests are to be carried out:

- Ensure that the pump has not been damaged during transportation or storage. Immediately report any damage to the supplier
- Check that the mains voltage is suitable for the motor
- Ensure that the hose is suitable for the fluid to be conveyed and that it is not damaged
- Make sure that the temperature of the liquid does not exceed the recommended temperature range
- Only switch the pump on if the front cover has been properly attached
- Check that the shoes are correctly fitted and fastened
- Check that the hose and shoes are sufficiently lubricated
- Check that the thermal overload protection (not included in the delivery scope) corresponds to the value specified on the motor type plate
- Check whether the direction of rotation is correctly adjusted
- Check that the optional electrical components are connected and are working properly
- Install a manometer in the pressure line if the back-pressure value is unknown

- Check the operating instructions in order to ensure that the flow values, pressures and power consumption of the motor do not exceed the rated values
- Install a pressure relief valve in the pressure line in order to protect the pump in the event that a valve is unintentionally closed off or the line is blocked in another way.

4.3.6.2 Filling level for pump housing



WARNING!

Danger from hazardous substances!

Possible consequence: Fatal or very serious injuries.

Please ensure when handling hazardous substances that you have read the latest safety data sheets provided by the manufacture of the hazardous substance. The actions required are described in the safety data sheet. Check the safety data sheet regularly and replace, if necessary, as the hazard potential of a substance can be re-evaluated at any time based on new findings.

The system operator is responsible for ensuring that these safety data sheets are available and that they are kept up to date, as well as for producing an associated hazard assessment for the workstations affected.



Check the lubricant level in the pump housing

Before commissioning, check that there is sufficient lubricant in the pump housing.

DULCO®flex Lubricant®, 5 litres, order number 1037254.

Pump	Filling level in litres
DFDa 025	2
DFDa 032	3
DFDa 040	5
DFDa 060	10
DFDa 070	30
DFDa 080	50
DFDa 100	70
DULCO®flex Lubricant®, 5 litres, order number 1037254	

5 Operating the DFDa

- **User qualification, operation:** instructed persons, see
↳ *Chapter 1.2 'Users' qualifications' on page 5*

The peristaltic pump is to be fully integrated into the customer's designated plant and is then controlled by this plant. It is not possible to operate the pump directly.

6 Maintenance, repair, troubleshooting, disposal and spare parts

- **User qualification, maintenance and disposal:** instructed personnel, see [Chapter 1.2 'Users' qualifications' on page 5](#)
- **User qualification, repair and troubleshooting:** trained user, see [Chapter 1.2 'Users' qualifications' on page 5](#)

6.1 Maintenance



CAUTION!

Disconnect the pump from the mains

Possible consequence: Personal injury

You may only carry out work on the pump after it has previously been switched off and disconnected from the mains.

Lubrication

- Check the lubricant filling level for the pump hose
 - Check every 200 operating hours
- Check whether the oil level is correct for the step-down gears
 - Exchange the oil at regular intervals in accordance with the step-down gear maintenance manual.

6.2 Exchanging the pump hoses

Exchanging the pump hoses - dismantling

1. ➤ Close off all valves, in order to prevent leakage of the feed chemical
2. ➤ Dismantle the pump hoses from both discharge and suction sides
3. ➤ Drain the lubricant from the pump housing. In order to do so, remove the plug from the rear side of the pump housing (drain plug and vent screw)
 - ⇒ Collect the lubricant with a container. Dispose of the lubricant in accordance with the specifications detailed on the lubricant safety data sheet.
4. ➤ Release the screw and remove both bearing flanges, including the sleeves.
5. ➤ Release both clamping rings from the hose



CAUTION!

Risk of injury from the rotor

Never remove the front cover from the pump. There is a risk of injury from the rotor.

6. ➤ Switch on the motor intermittently and thereby remove the pump hose from the pump housing.
7. ➤ Check all of the dismantled parts
 - ⇒ If necessary, replace parts with new ones.

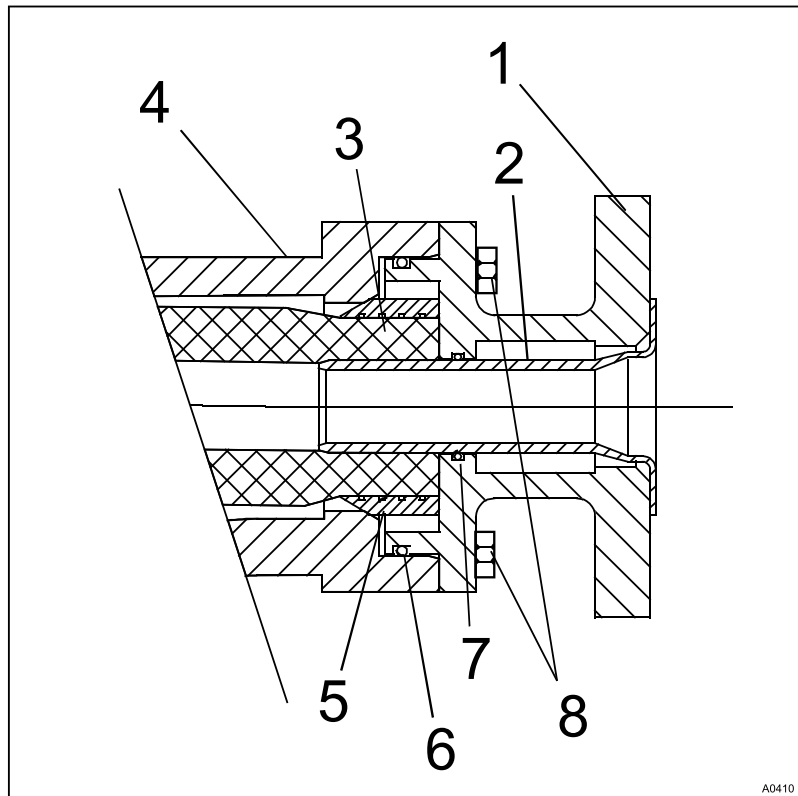

Fig. 13: Overview of bearing flange

- 1 Bearing flange
- 2 Flange sleeve
- 3 Pump hose
- 4 Pump housing
- 5 Clamping ring
- 6 O-ring external
- 7 O-ring internal
- 8 Flange screws (4 pieces)

Exchanging the pump hoses - installation

1. ➤ Remove the front cover and clean the inner surface of the pump housing
2. ➤ Check the shoes. Ensure that the sliding surfaces are not damaged
 - ⇒ If necessary, replace the shoes
3. ➤ Attach the front cover to the pump housing again
4. ➤ Attach the bearing flange to the discharge side with 2 screws. In order to do so, fasten the screws diagonally
 - ⇒ Release the screws after tightening by a 1/2 turn
5. ➤ Attach the pump hose over the suction side into the pump housing
 - ⇒ Switch the motor off when the pump hose has reached the bearing flange on the discharge side.
6. ➤ Remove the bearing flange again and slide the clamping ring flush over the pump hose
 - ⇒ The pump hose projects 10 mm out of the pump housing.
7. ➤ Lay the inner O-ring in the bearing flange and slide the flange sleeve into the bearing flange.
8. ➤ Position the outer o-ring in the bearing flange.

9. ➤ Now carefully screw the bearing flange with the four screws onto the pump housing.
In doing so, ensure that the flange sleeve is not damaged. If necessary, knock the flange sleeve in with a plastic-faced hammer
10. ➤ Now fasten the bearing flange and clamping ring on the suction side in the same way as the description for the discharge side
11. ➤ Screw the drain plug and vent screw back into the pump housing
12. ➤ Fill the pump with lubricant by means of the filler inlet up to the filling level mark.
13. ➤ Close the filler inlet
14. ➤ Mount the pipes on both the discharge and suction sides
15. ➤ Open all of the valves

6.3 Troubleshooting

Problem	Possible cause	Solution
Increased pump temperature	Pump housing has no lubricant	Fill lubricant, see ↗ <i>Chapter 4.3.6.2 'Filling level for pump housing' on page 37</i>
	Increased product temperature	Reduce product temperature
	Insufficient or poor suction conditions	Check suction line for blockages
	Pump speed too high	Reduce pump speed
Reduced flow or pressure	Valves on discharge and or suction side completely or partially closed	Open valves
	Pump hose insufficiently compressed	Check shoe fixing
	Pump hose rupture (the product leaks out into the housing)	Replace pump hose
	Partial blockage of the suction line	Clean pipes
	Insufficient product quantity in storage tank	Fill storage tank or switch off pump
	Insufficient diameter on the suction side	Increase the diameter on the suction side, as far as possible
	Suction line too long	Shorten the suction line, as far as possible
	High viscosity of medium	Reduce viscosity, as far as possible
	Air entry through the suction connectors	Check connectors and accessories for air tightness
Vibrations on pumps and pipe-work	The pipes are not correctly fastened	Fasten pipes correctly (e.g. wall brackets)
	Pump speed too high	Reduce pump speed

Problem	Possible cause	Solution
	Insufficient nominal width of the pipes	Increase nominal width
	Pump base plate loose	Fasten base plate
	Pulsation dampers insufficient or missing	Install pulsation dampers on suction and/or discharge side.
Short service life of the hose	Exposure to chemicals	Check the compatibility of the hose with the liquid being pumped, the cleaning fluid and the lubricant
	High pump speed	Reduce pump speed
	High pump temperature	Reduce product temperature
	High operating pressure	Reduce operating pressure
	Pump cavitation	Check the suction conditions
Pump hose pulled into the pump housing	High inlet pressure (> 3 bar)	Reduce inlet pressure
	Pump hose filled with deposits	Clean or replace the pump hose
	Bearing flange insufficiently tightened	Tighten bolts
The pump does not start up	Insufficient motor performance	Check motor and replace if necessary
	Insufficient output from frequency converter	The frequency converter must match the motor
		Check voltage. Start only happens at a minimum of 10 Hz
Blockage in the pump	Check if the suction or discharge side is blocked. Eliminate blockage	

6.4 Disposal of Used Parts

- **User qualification:** instructed user, see [Chapter 1.2 'Users' qualifications'](#) on page 5



NOTICE!

Regulations governing the disposal of used parts

- Note the current national regulations and legal standards which apply in your country

The manufacturer will take back decontaminated used units providing they are covered by adequate postage.

Decontaminate the unit before returning it for repair. To do so, remove all traces of hazardous substances. Refer to the Material Safety Data Sheet for your feed chemical.

A current Declaration of Decontamination is available to download on the ProMinent website.

6.5 Spare parts

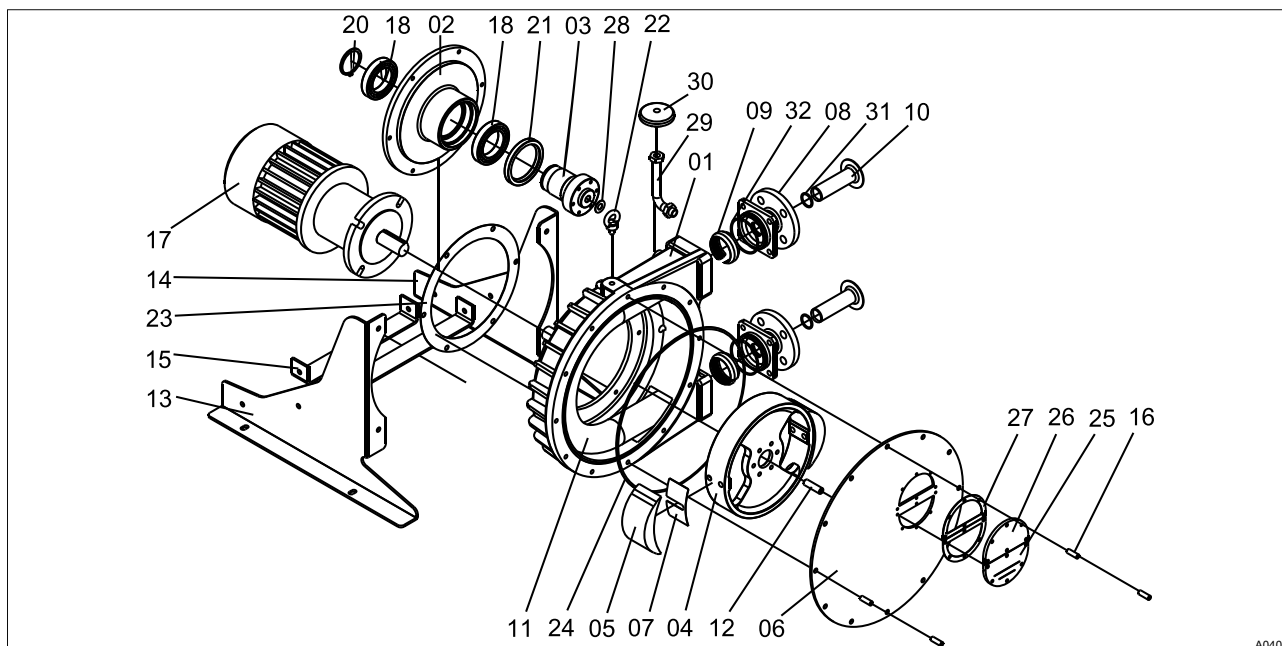

Fig. 14: Exploded view of spare parts for DFDa 025

DFDa 025

see Fig. 14

Item	Description	Quantity	Reference	Part number
1	Pump housing	1	100.01.01	
2	Housing, ball bearing	1	100.01.03	
3	Rotor shaft	1	100.01.14	
4	Rotor	1	100.01.16	
5	Shoes	2	100.01.17	
6	Front cover	1	100.00.07	
7	Spacer plate		100.01.13	
8	Pressure flange	2	100.00.06	
	Pressure flange, ANSI	2	100.00.40	
9	Clamp ring	2	100.01.05	
10	Insert, VA	2	100.00.04	
	Insert, PP	2	100.00.15	
	Insert, PVDF	2	100.00.34	
11	Pump hose, NR	1	100.01.08	1037219
	Pump hose, NBR	1	100.01.09	1037220
	Pump hose, EPDM	1	100.01.10	1037221
12	Cap	1	104.01.23	
13	Base plate, left	1	100.01.24	
	Base plate, left, stainless steel	1	100.01.34	

DFDa 025

see Fig. 14

Item	Description	Quantity	Reference	Part number
14	Base plate, right	1	100.01.25	
	Base plate, right, stainless steel	1	100.01.35	
15	Base plate, centre	2	100.01.26	
	Base plate, centre, stainless steel	2	100.01.36	
16	Stud bolts	2	102.00.14	
17	Power end/drive	1		
18	Ball bearing	2	100.01.28	
20	Safety collar	1	100.01.31	
21	Seal	1	100.01.32	
22	Lifting lug	1	106.00.40	
23	Housing seal	1	100.01.33	
24	O-ring, front cover	1	100.00.17	
25	Inspection window for maintenance, with filling level mark	1	104.00.36	
26	Inspection window for maintenance	1	104.00.35	
27	Seal, inspection window for maintenance	2	104.00.37	
28	Seal, shaft cap	1	104.00.38	
29	Vent pipe	1	104.00.41	
30	Cap, vent pipe	1	104.00.42	
31	O-ring, external	2	100.00.19	
32	O-ring, internal	2	100.00.18	
33	Discharge screw, RBT	2	100.00.44	

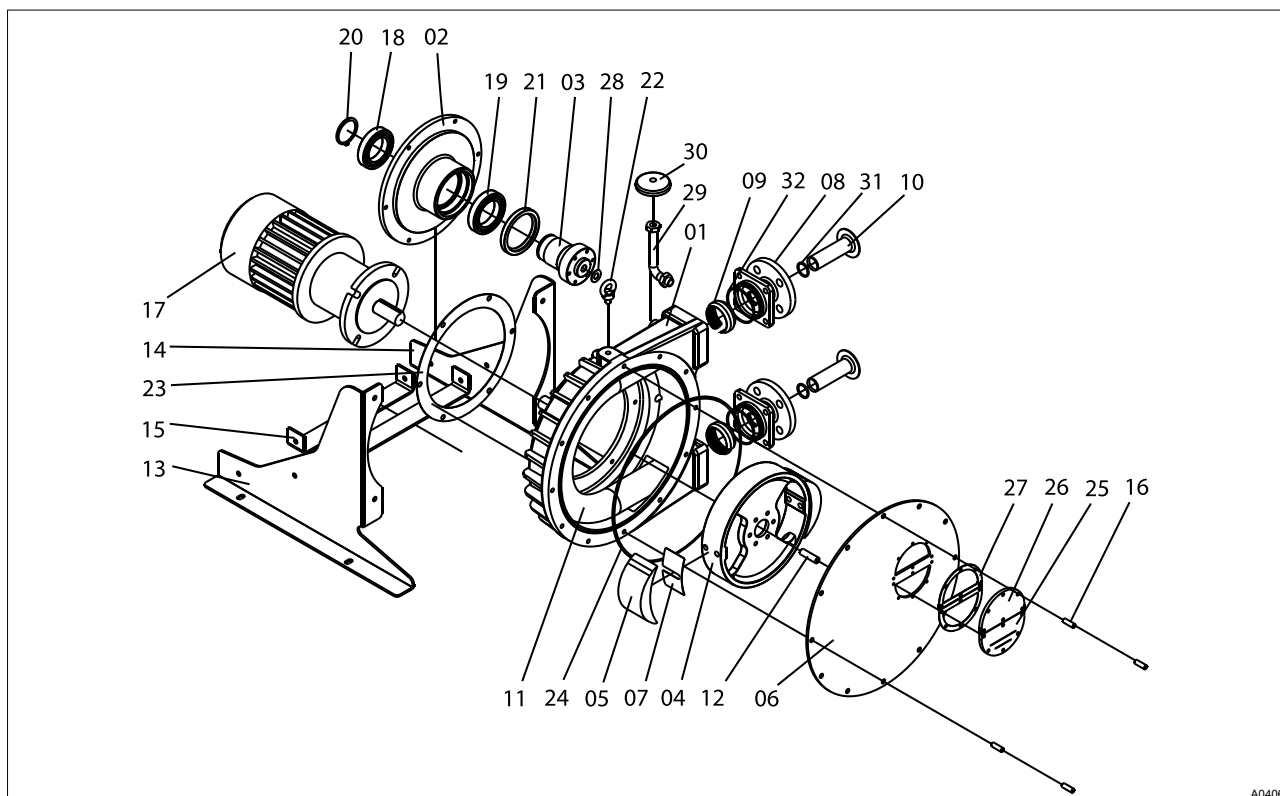

Fig. 15: Exploded view of spare parts for DFDa 032

DFDa 032

see Fig. 15

Item	Description	Quantity	Reference	Part number
1	Pump housing	1	104.01.01	
2	Housing, ball bearing	1	104.01.03	
3	Rotor shaft	1	104.01.14	
4	Rotor	1	104.01.16	
5	Shoes	2	104.01.17	
6	Front cover	1	104.00.07	
7	Spacer plate	1	104.01.13	
8	Pressure flange	2	104.00.06	
	Pressure flange, ANSI	2	104.00.40	
9	Clamp ring	2	104.00.05	
10	Insert, VA	2	104.00.04	
	Insert, PP	2	104.00.15	
	Insert, PVDF	2	104.00.34	
11	Pump hose, NR	1	104.01.08	1037225
	Pump hose, NBR	1	104.01.09	1037226
	Pump hose, EPDM	1	104.01.10	1037227
12	Cap	1	104.01.23	

DFDa 032

see Fig. 15

Item	Description	Quantity	Reference	Part number
13	Base plate, left	1	106.00.24	
14	Base plate, right	1	106.00.25	
15	Base plate, centre	2	106.00.26	
16	Stud bolts	2	106.00.27	
17	Power end/drive	1		
18	Ball bearing	1	106.00.28	
19	Ball bearing	1	106.00.29	
20	Safety collar	1	106.00.31	
21	Seal	1	106.00.32	
22	Lifting lug	1	106.00.40	
23	Housing seal	1	104.00.33	
24	O-ring, front cover	1	104.00.17	
25	Inspection window for maintenance, with filling level mark	1	104.00.36	
26	Inspection window for maintenance	1	104.00.35	
27	Seal, inspection window for maintenance	2	104.00.37	
28	Seal, shaft cap	1	104.00.38	
29	Vent pipe	1	104.00.41	
30	Cap, vent pipe	1	104.00.42	
31	O-ring, external	2	104.00.19	
32	O-ring, internal	2	104.00.18	
33	Discharge screw, RBT	2	100.00.44	

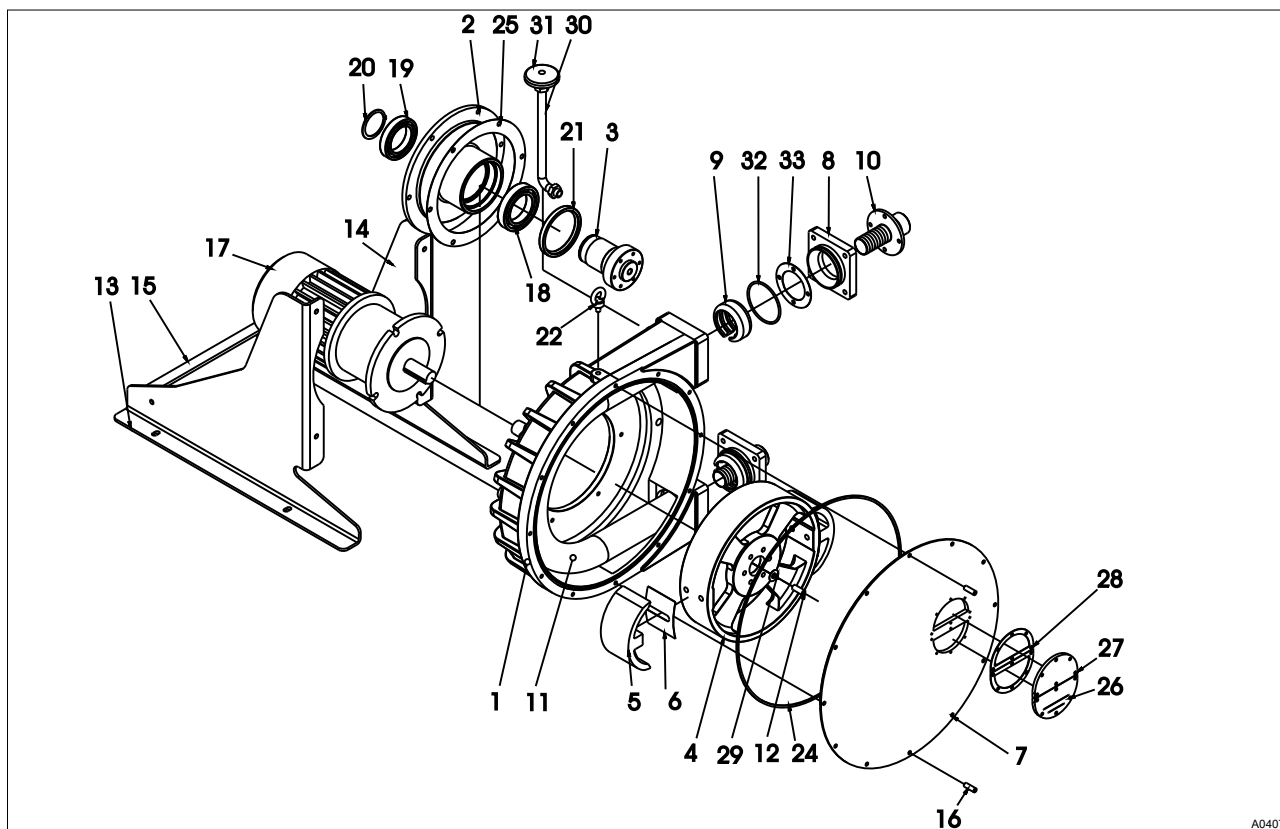

Fig. 16: Exploded view of spare parts for DFDa 040

DFDa 040

see Fig. 16

Item	Description	Quantity	Reference	Part number
1	Pump housing	1	109.00.01	
2	Housing, ball bearing	1	108.00.02	
3	Rotor shaft	1	108.00.03	
4	Rotor	1	109.00.02	
5	Shoes	2	109.00.03	
6	Spacer plate	1	109.00.04	
7	Front cover	1	109.00.05	
8	Pressure flange	2	109.00.06	
9	Clamp ring	2	108.00.12	
10	Connecting flange, DN 40, VA	2	108.00.13	
	Connecting flange, DN 40, ANSI, VA	2	108.00.14	
	Connecting flange, DN 40, PP	2	108.00.16	
	Connecting flange, DN 40, ANSI, PP	2	108.00.17	
	Connecting flange, DN 40, PVDF	2	108.00.18	
	Connecting flange, DN 40, ANSI, PVDF	2	108.00.19	
	Connecting flange, DIN 11851, NW 50	2	108.00.15	
11	Pump hose, NR	1	108.00.20	1037199

DFDa 040

see Fig. 16

Item	Description	Quantity	Reference	Part number
	Pump hose, NBR	1	108.00.22	1037201
	Pump hose, EPDM	1	108.00.24	1037202
12	Cap	1	104.01.23	
13	Base plate, left	1	108.00.26	
	Base plate, left, stainless steel	1	108.00.36	
14	Base plate, right	1	108.00.27	
	Base plate, right, stainless steel	1	108.00.37	
15	Base plate, centre	2	108.00.28	
	Base plate, centre, stainless steel	2	108.00.38	
16	Stud bolts	2	106.00.27	
17	Power end/drive	1		
18	Ball bearing	1	108.00.29	
19	Ball bearing	1	108.00.30	
20	Safety collar	1	108.00.32	
21	Seal	1	108.00.33	
22	Lifting lug	1	106.00.40	
23	Discharge screw, RBT	2	107.00.41	
24	O-ring, front cover	1	108.00.35	
25	Housing seal	1	109.00.14	
26	Inspection window for maintenance, with filling level mark	1	104.00.36	
27	Inspection window for maintenance	1	104.00.35	
28	Seal, inspection window for maintenance	2	104.00.37	
29	Seal, shaft cap	1	109.00.15	
30	Vent pipe	1	109.00.16	
31	Cap, vent pipe	1	109.00.17	
32	O-ring, pressure flange	2	109.00.18	
33	Seal, pressure flange	2	109.00.19	

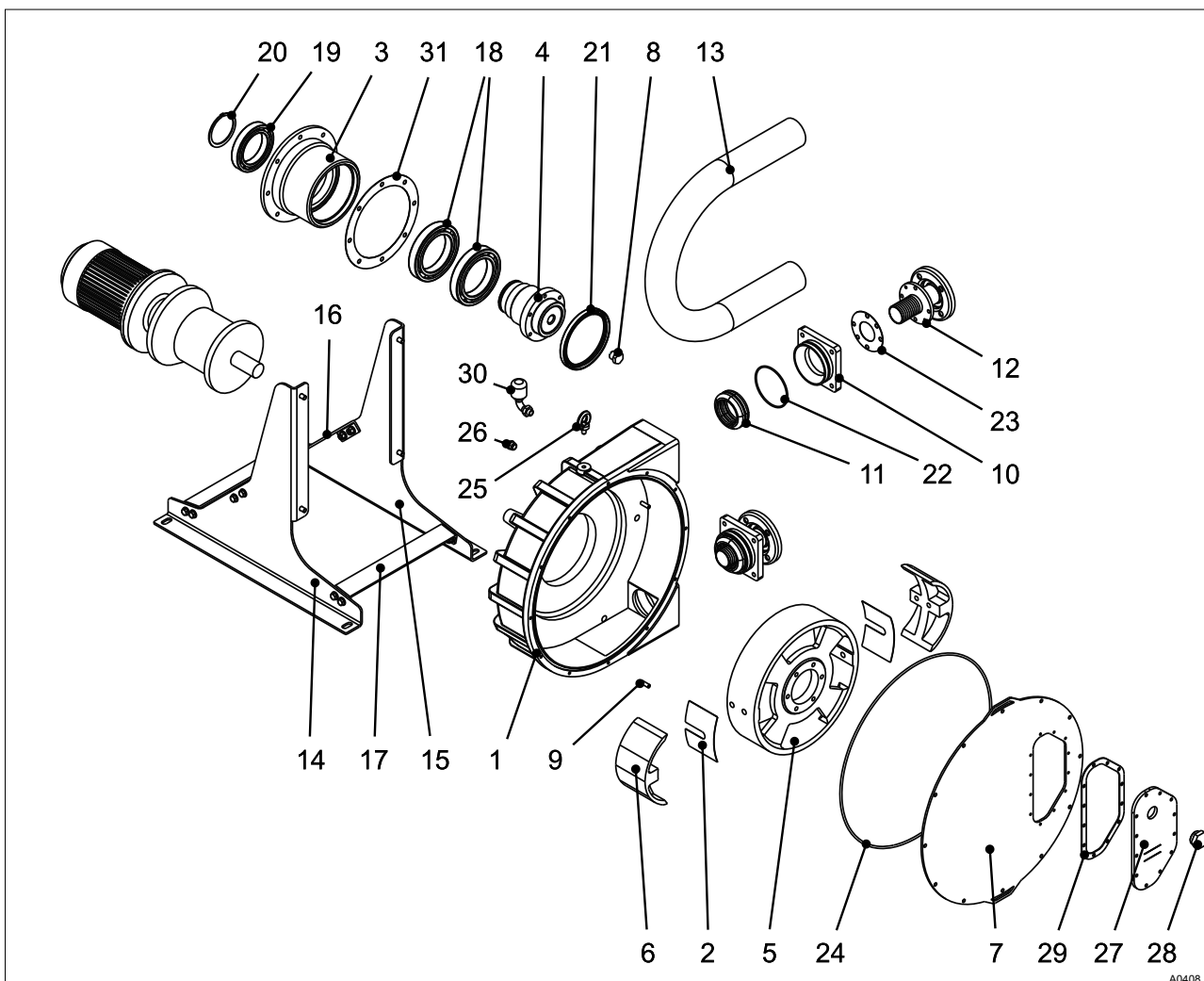

Fig. 17: Exploded view of spare parts for DFDa 060

DFDa 060

see Fig. 17

Item	Description	Quantity	Reference	Part number
1	Pump housing	1	111.01.01	
2	Spacer plate	2	111.00.02	
3	Housing, ball bearing	1	111.00.03	
4	Rotor shaft	1	111.00.04	
5	Rotor	1	111.00.05	
6	Shoes	2	111.00.06	
7	Front cover	1	111.01.07	
8	Cap M24	1	111.00.08	
9	Stud bolts	2	106.00.27	
10	Pressure flange	2	110.01.15	
11	Clamp ring	2	110.01.16	
12	Connecting flange, DIN, VA	2	110.01.17	

DFDa 060

see Fig. 17

Item	Description	Quantity	Reference	Part number
	Connecting flange, ANSI, VA	2	110.01.41	
	Connecting flange, DIN, PVDF/PTFE	2	110.01.72	
	Connecting flange, ANSI, PVDF/PTFE	2	110.01.65	
	Connecting flange, DIN, PP	2	110.01.64	
	Connecting flange, ANSI, PP	2	110.01.63	
13	Pump hose, NR	1	111.00.18	1037236
	Pump hose, NBR	1	111.00.20	1037237
	Pump hose, EPDM	1	111.00.22	1037238
14	Base plate, left	1	110.00.37	
	Base plate, left, VA	1	110.00.48	
15	Base plate, right	1	110.00.38	
	Base plate, right, VA	1	110.00.49	
16	Base plate, centre, 100 mm	1	110.00.39	
	Base plate, centre, 100 mm, VA	1	110.00.50	
17	Base plate, centre, 60 mm	2	110.00.40	
	Base plate, centre, 60 mm, VA	2	110.00.51	
18	Ball bearing, front	2	111.00.28	
19	Ball bearing, rear	1	111.00.29	
20	Safety collar	1	111.00.30	
21	Seal	1	111.00.31	
22	O-ring, connecting flange	2	111.01.53	
23	Seal, connector	2	111.01.54	
24	O-ring, front cover	1	111.00.25	
25	Lifting lug	1	111.00.26	
26	Discharge screw	2	100.00.44	
27	Inspection window for maintenance	1	111.01.38	
28	Filling cap	1	111.01.57	
29	Seal, inspection window for maintenance	1	111.01.40	
30	Vent pipe	1	111.01.58	
31	Seal, housing, ball bearing	1	111.00.45	

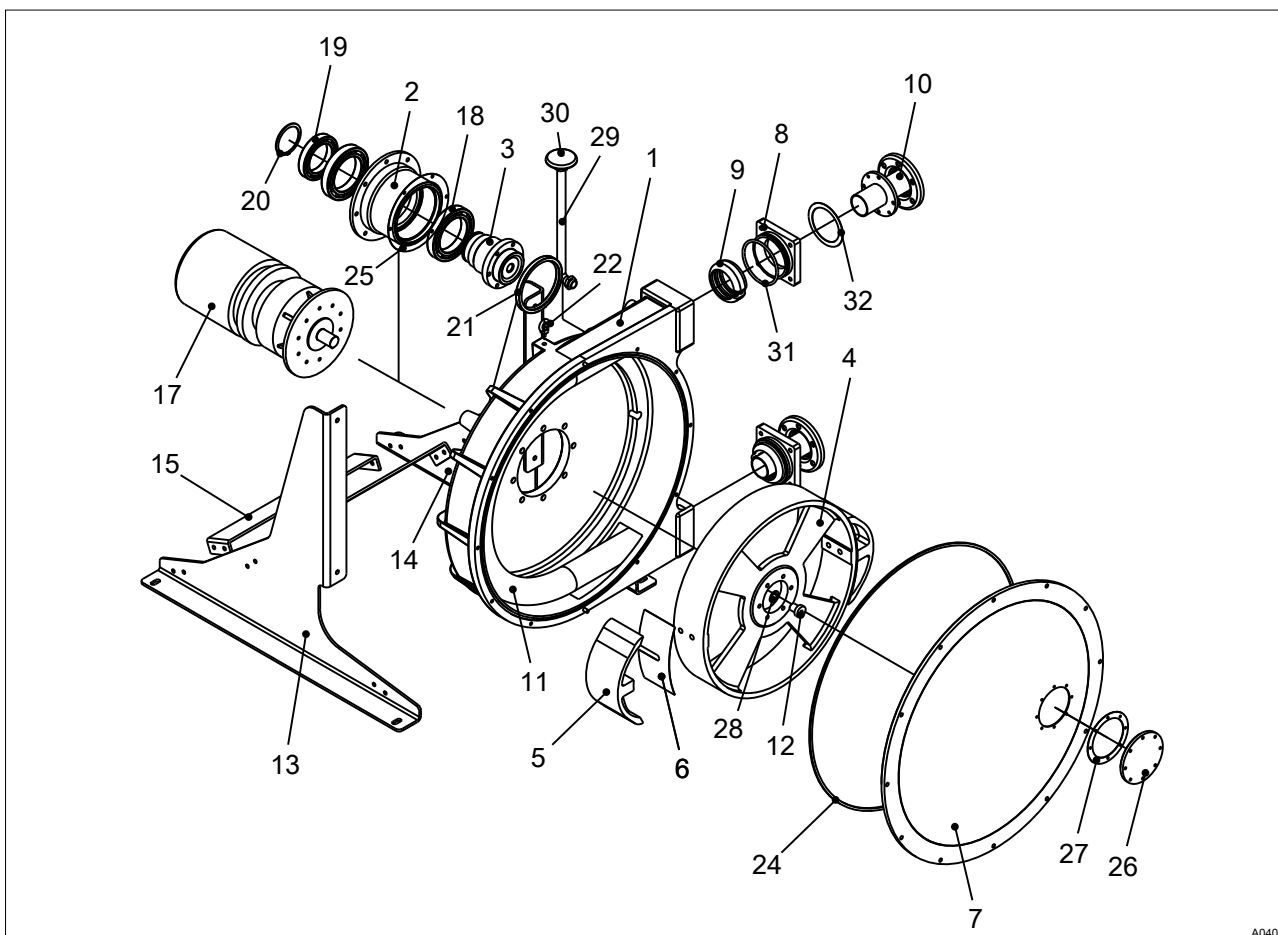

Fig. 18: Exploded view of spare parts for DFDa 070

DFDa 070				
see Fig. 18				
Item	Description	Quantity	Reference	Part number
1	Pump housing	1	112.00.01	
2	Ball bearing housing	1	111.00.03	
3	Rotor shaft	1	111.00.04	
4	Rotor	1	114.00.01	
5	Shoes	2	114.00.02	
6	Spacer plate	1	114.00.03	
7	Front cover	1	114.00.04	
8	Pressure flange	2	114.00.05	
9	Clamp ring	2	112.00.10	
10	Connecting flange, DN 65, VA	2	112.00.11	
	Connecting flange, DN 65, ANSI, VA	2	112.00.12	
	Connecting flange, DN 65, PP	2	112.00.14	
	Connecting flange, DN 65, ANSI, PP	2	112.00.15	
	Connecting flange, DN 65, PVDF	2	112.00.16	
	Connecting flange, DN 65, ANSI, PVDF	2	112.00.17	

DFDa 070

see Fig. 18

Item	Description	Quantity	Reference	Part number
	Connecting flange, DIN 11851, NW 65	2	112.00.13	
	Connecting flange, TRI-CLAMP®	2	112.00.43	
11	Pump hose, NR	1	112.00.18	1037213
	Pump hose, NBR	1	112.00.20	1037214
	Pump hose, EPDM	1	112.00.22	1037215
12	Cap	1	111.00.08	
13	Base plate, left	1	112.00.24	
	Base plate, left, stainless steel	1	112.00.36	
14	Base plate, right	1	112.00.25	
	Base plate, right, stainless steel	1	112.00.37	
15	Base plate, centre	3	112.00.26	
	Base plate, centre, stainless steel	3	112.00.38	
16	Stud bolts	2	112.00.44	
17	Power end/drive	1		
18	Ball bearing	2	111.00.28	
19	Ball bearing	1	111.00.29	
20	O-ring, rotor shaft	1	111.00.30	
21	Seal	1	111.00.31	
22	Lifting lug	1	112.00.29	
23	Discharge screw, RBT	2	114.00.06	
24	O-ring, front cover	1	112.00.35	
25	Housing seal	1	111.00.45	
26	Inspection window for maintenance	1	114.00.11	
27	Seal, inspection window for maintenance	1	114.00.12	
28	Seal, shaft	1	111.00.44	
29	Vent pipe	1	114.00.07	
30	Cap, vent pipe	1	114.00.08	
31	O-ring, pressure flange	2	114.00.09	
32	Seal, pressure flange	2	114.00.10	

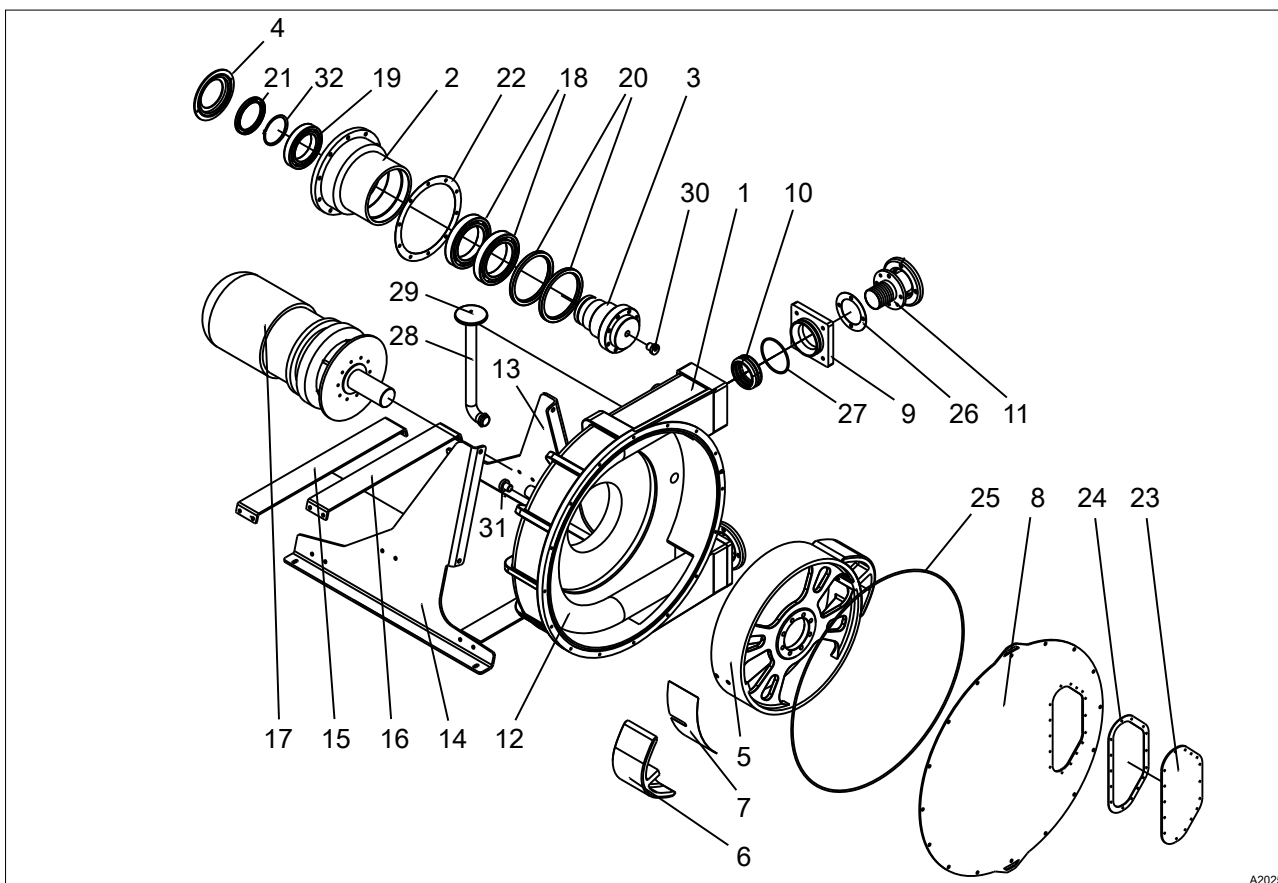

Fig. 19: Exploded view of spare parts for DFda 080

DFda 080

see Fig. 19

Pos.	Description	Quantity	Reference	Part number
1	Pump housing	1	118.00.01	
2	Ball bearing housing	1	119.00.02	
3	Rotor shaft	1	119.00.03	
4	Lipped seal, ball bearing	1	119.00.04	
5	Rotor	1	118.00.02	
6	Shoe	2	118.00.03	
7	Spacer	1	118.00.10	
8	Front cover	1	118.00.08	
9	Pressure flange	2	118.00.04	
10	Hose clamp ring	2	118.00.06	
11	Connecting flange, 3", PP, ANSI	2	118.00.27	
11	Connecting flange, 3", PP, ANSI	2	118.00.29	
11	Connecting flange, 3", PVDF, ANSI	2	118.00.31	
11	Connecting flange, 4", Tri-CLAMP®	2	118.00.33	
11	Connecting flange, DN-80, PP, DIN	2	118.00.28	
11	Connecting flange, DN-80, PVDF, DIN	2	118.00.30	

DFDa 080

see Fig. 19

Pos.	Description	Quantity	Reference	Part number
11	Connecting flange, DN-80, VA, DIN 11851	2	118.00.32	
11	Connecting flange, DN-80, VA, DIN	2	118.00.05	
12	Pump hose, EPDM	1	118.00.14	1041679
12	Pump hose, NBR	1	118.00.13	1041678
12	Pump hose, NR	1	118.00.12	1041677
13	Mounting frame, right, steel	1	118.00.21	
13	Mounting frame, right, VA	1	118.00.34	
14	Mounting frame, left, steel	1	118.00.20	
14	Mounting frame, left, VA	1	118.00.35	
15	Mounting frame, long, steel	2	118.00.19	
15	Mounting frame, long, VA	2	118.00.36	
16	Mounting frame, short, steel	1	118.00.18	
16	Mounting frame, short, VA	1	118.00.37	
18	Ball bearing, front	2	119.00.33	
19	Ball bearing, rear	1	119.00.34	
20	Lipped seal, ball bearing (front)	2	119.00.35	
21	Lipped seal, ball bearing (rear)	1	119.00.36	
22	Seal, ball bearing	1	119.00.37	
23	Inspection window	1	118.00.09	
24	Seal, inspection window	1	118.00.11	
25	O-ring, front cover	1	118.00.25	
26	Seal, pressure flange	2	118.00.07	
27	O-ring, pressure flange	2	118.00.26	
28	Vent pipes	1	118.00.22	
29	Cap, vent pipe	1	118.00.23	
30	Bearing cover	1	119.00.45	
31	Discharge screw	2	118.00.24	
32	Safety collar, ball bearing	1	119.00.47	

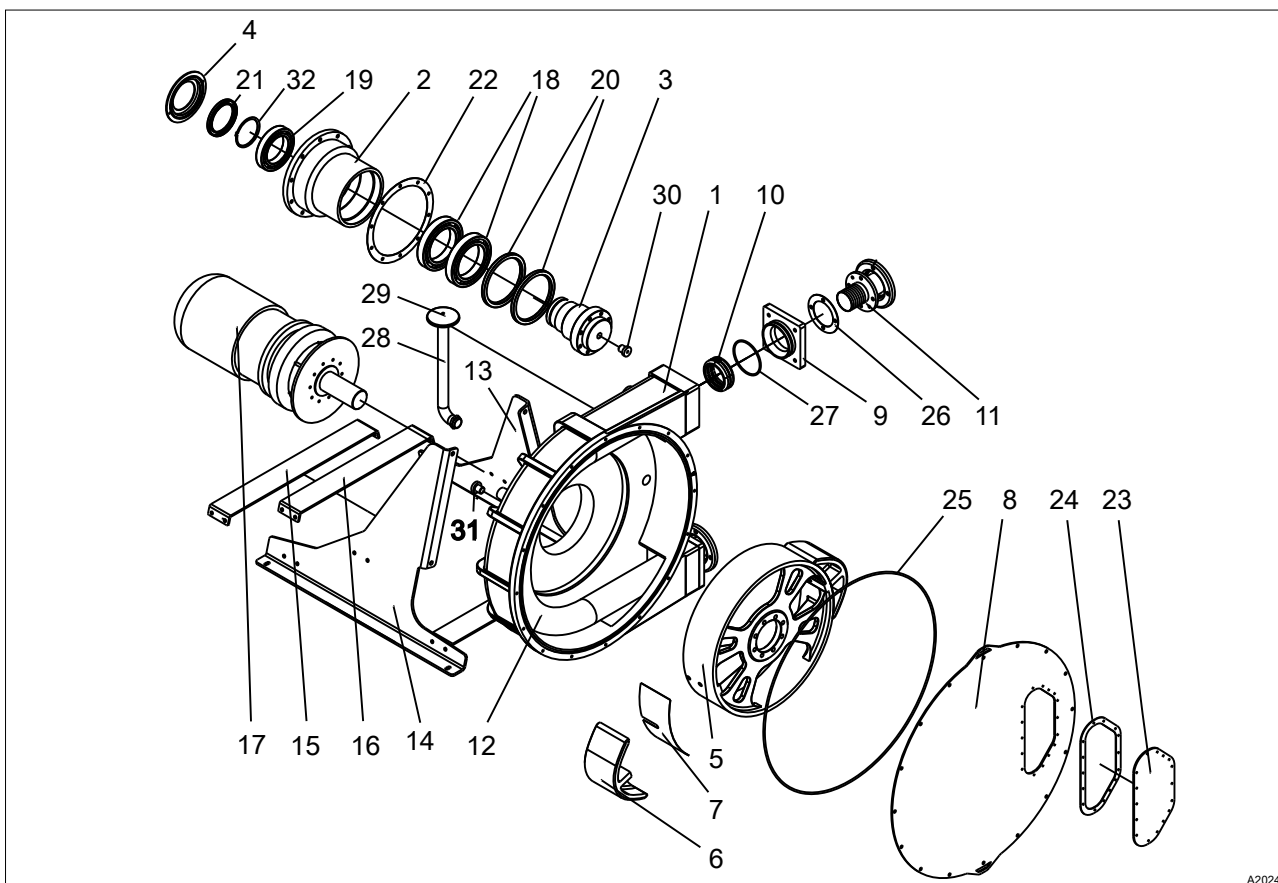

Fig. 20: Exploded view of spare parts for DFDa 100

DFDa 100

see Fig. 20

Pos.	Description	Quantity	Refer-ence	Part number
1	Pump housing	1	119.00.01	
2	Ball bearing housing	1	119.00.02	
3	Rotor shaft	1	119.00.03	
4	Lipped seal, ball bearing	1	119.00.04	
5	Rotor	1	119.00.05	
6	Shoe	2	119.00.06	
7	Spacer	1	119.00.07	
8	Front cover	1	119.00.08	
9	Pressure flange	2	119.00.09	
10	Hose clamp ring	2	119.00.10	
11	Connecting flange, 4", PP, ANSI	2	119.00.14	
11	Connecting flange, 4", PVDF, ANSI	2	119.00.16	
11	Connecting flange, 4", VA, ANSI	2	119.00.12	
11	Connecting flange, 4", Tri-CLAMP®	2	119.00.18	
11	Connecting flange, DN-100, PP, DIN	2	119.00.13	

DFDa 100

see Fig. 20

Pos.	Description	Quantity	Reference	Part number
11	Connecting flange, DN-100, PVDF, DIN	2	119.00.15	
11	Connecting flange, DN-100, VA, DIN 11851	2	119.00.17	
11	Connecting flange, DN-100, VA, DIN	2	119.00.11	
12	Pump hose, EPDM	1	119.00.21	1037249
12	Pump hose, NBR	1	119.00.20	1037248
12	Pump hose, NR	1	119.00.19	1037247
13	Mounting frame, right, steel	1	119.00.25	
13	Mounting frame, right, VA	1	119.00.26	
14	Mounting frame, left, steel	1	119.00.27	
14	Mounting frame, left, VA	1	119.00.28	
15	Mounting frame, long, steel	2	119.00.29	
15	Mounting frame, long, VA	2	119.00.30	
16	Mounting frame, short, steel	1	119.00.31	
16	Mounting frame, short, VA	1	119.00.32	
18	Ball bearing, front	2	119.00.33	
19	Ball bearing, rear	1	119.00.34	
20	Lipped seal, ball bearing (front)	2	119.00.35	
21	Lipped seal, ball bearing (rear)	1	119.00.36	
22	Seal, ball bearing	1	119.00.37	
23	Inspection window	1	119.00.38	
24	Seal, inspection window	1	119.00.39	
25	O-ring, front cover	1	119.00.40	
26	Seal, pressure flange	2	119.00.41	
27	O-ring, pressure flange	2	119.00.42	
28	Vent pipes	1	119.00.43	
29	Cap, vent pipe	1	119.00.44	
30	Bearing cover	1	119.00.45	
31	Discharge screw	2	119.00.46	
32	Safety collar, ball bearing	1	119.00.47	

Lubricant

Item	Description	Quantity	Reference	Part number
1	DULCO®flex Lubricant®	5 litres		1037254

7 DFDa Technical Data

Type DFDa	Feed rate in l/revolution	P max. in bar	Pump capacity at max. pressure in l/h	Rollers/ Shoes	Hose interior ø in mm	Solids max. ø in mm	Weight without drive in kg	Connector DN
025	0.3	15	504	Shoes	25	6.3	57	25
032	0.625	15	787	Shoes	32	8.0	89	32
040	1.33	15	2075	Shoes	40	10.0	150	40
060	2.9	15	3800	Shoes	57	14.3	252	50
070	6.7	15	7200	Shoes	65	16.3	530	65
080	11.7	15	8700	Shoes	80	20.0	900	80
100	20.0	15	14400	Shoes	100	25.0	1100	100

7.1 Dimensions DFDa 025

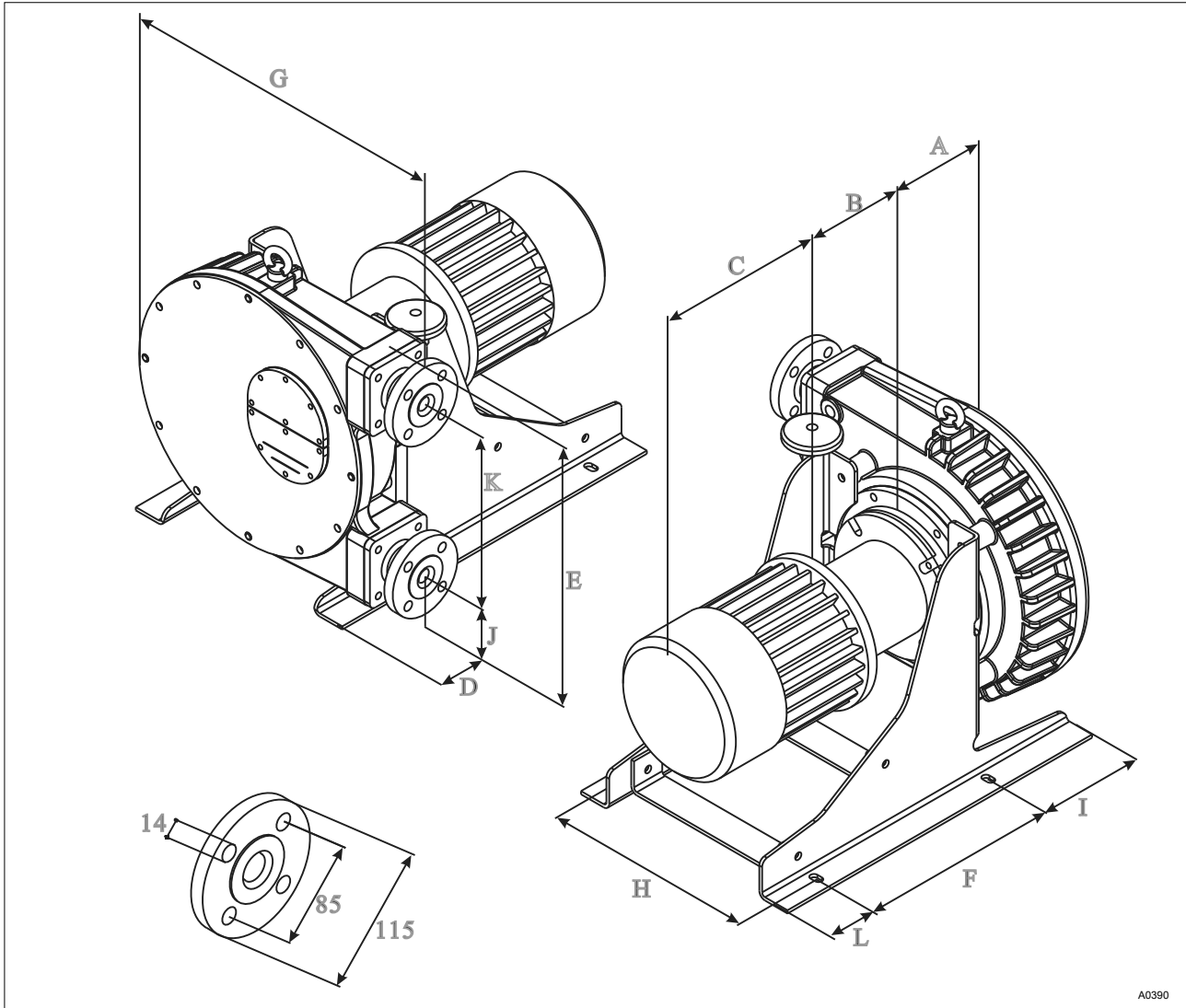
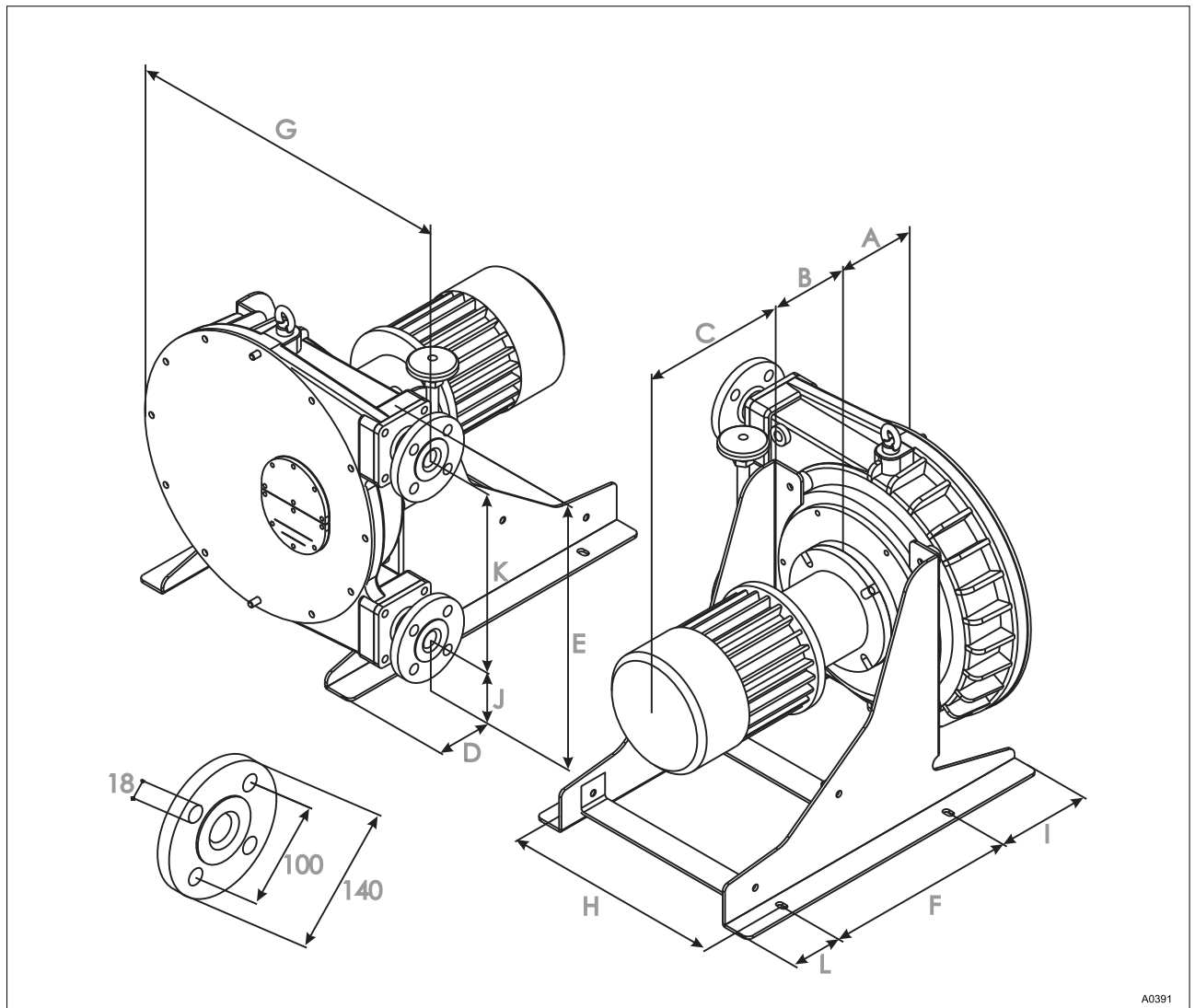

Fig. 21: Dimensions DFDa 025

A	127.5 mm	H	305 mm
B	*	I	160 mm
C	*	J	100 mm
D	60 mm	K	262 mm
E	425 mm	L	75 mm
F	305 mm	*	Dependent on selected drive
G	471 mm		

7.2 Dimensions DFDa 032



A0391

Fig. 22: Dimensions DFDa 032

A 135 mm
 B *
 C *
 D
 E 613 mm
 F 345 mm
 G 552 mm

H 385 mm
 I 170 mm
 J 130 mm
 K 330 mm
 L 95
 * Dependent on selected drive

7.3 Dimensions DFDa 040

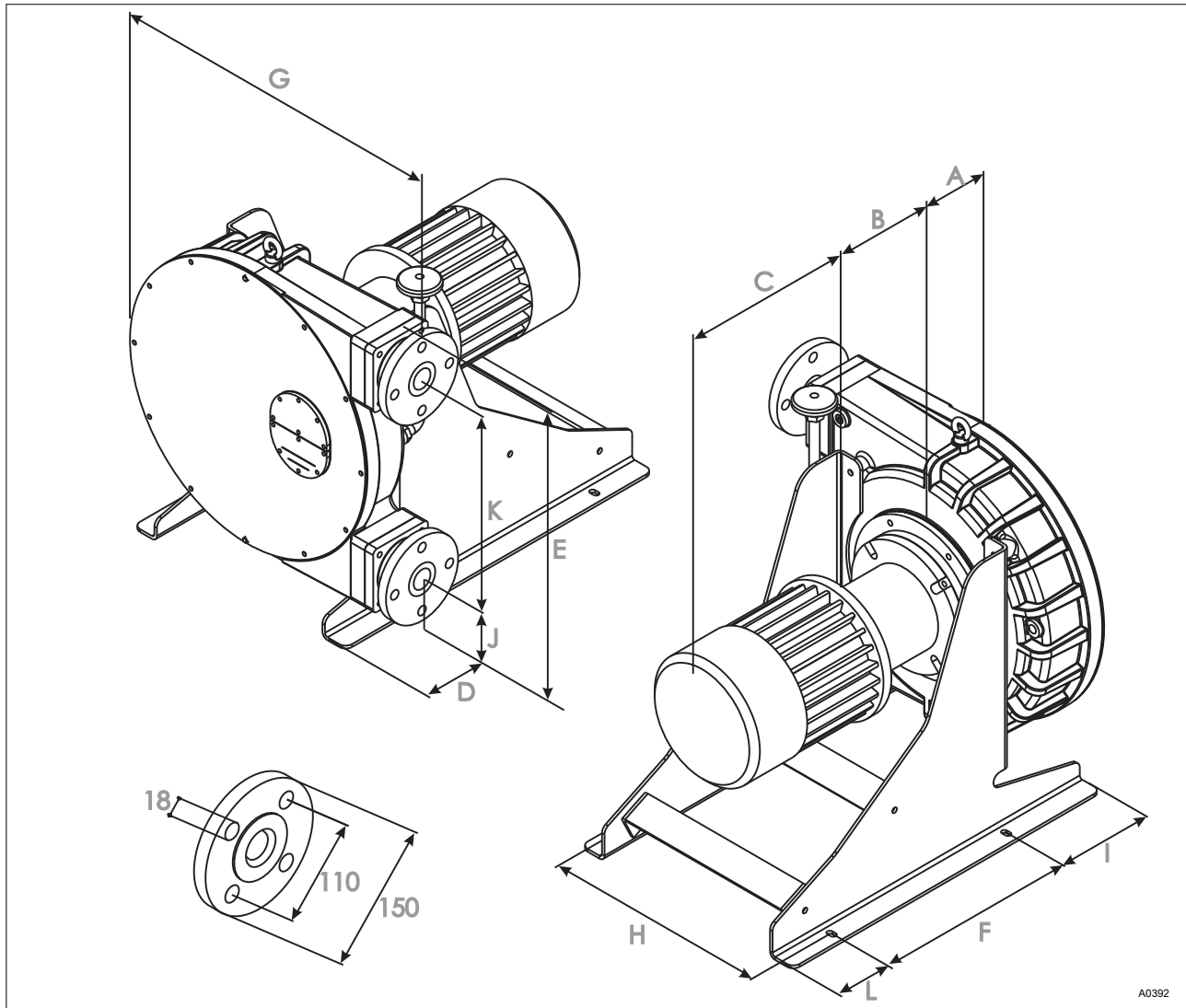
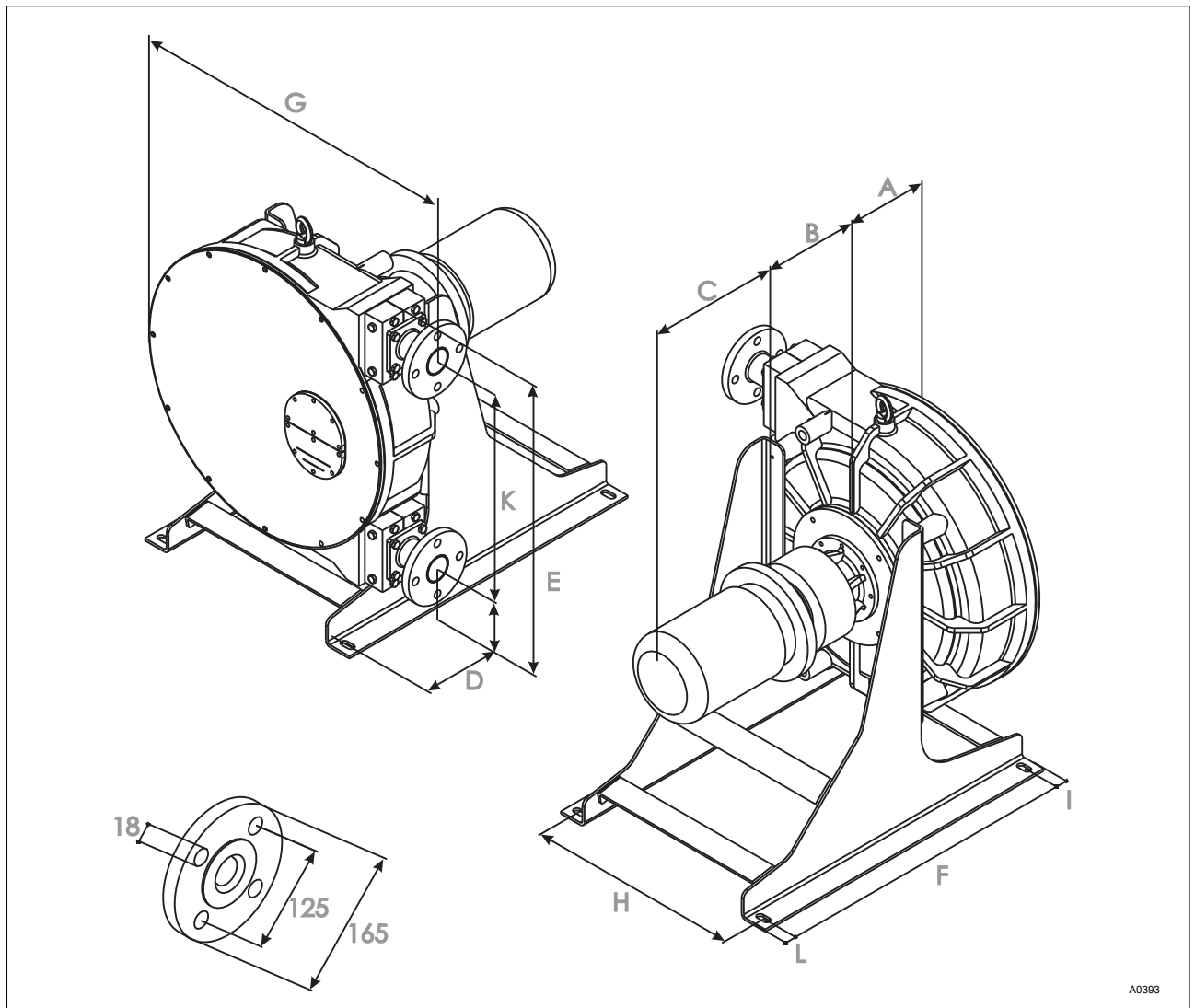

Fig. 23: Dimensions DFDa 040

A	151 mm	H	456 mm
B	*	I	200 mm
C	*	J	159 mm
D	79 mm	K	412 mm
E	645 mm	L	115 mm
F	415 mm	*	Dependent on selected drive
G	633 mm		

7.4 Dimensions DFDa 060



A0393

Fig. 24: Dimensions DFDa 060

A 215 mm
 B *
 C *
 D 111 mm
 E 805 mm
 F 740 mm
 G 735 mm

H 500 mm
 I 25 mm
 J 210 mm
 K 510 mm
 L 25 mm
 * Dependent on selected drive

7.5 Dimensions DFDa 070

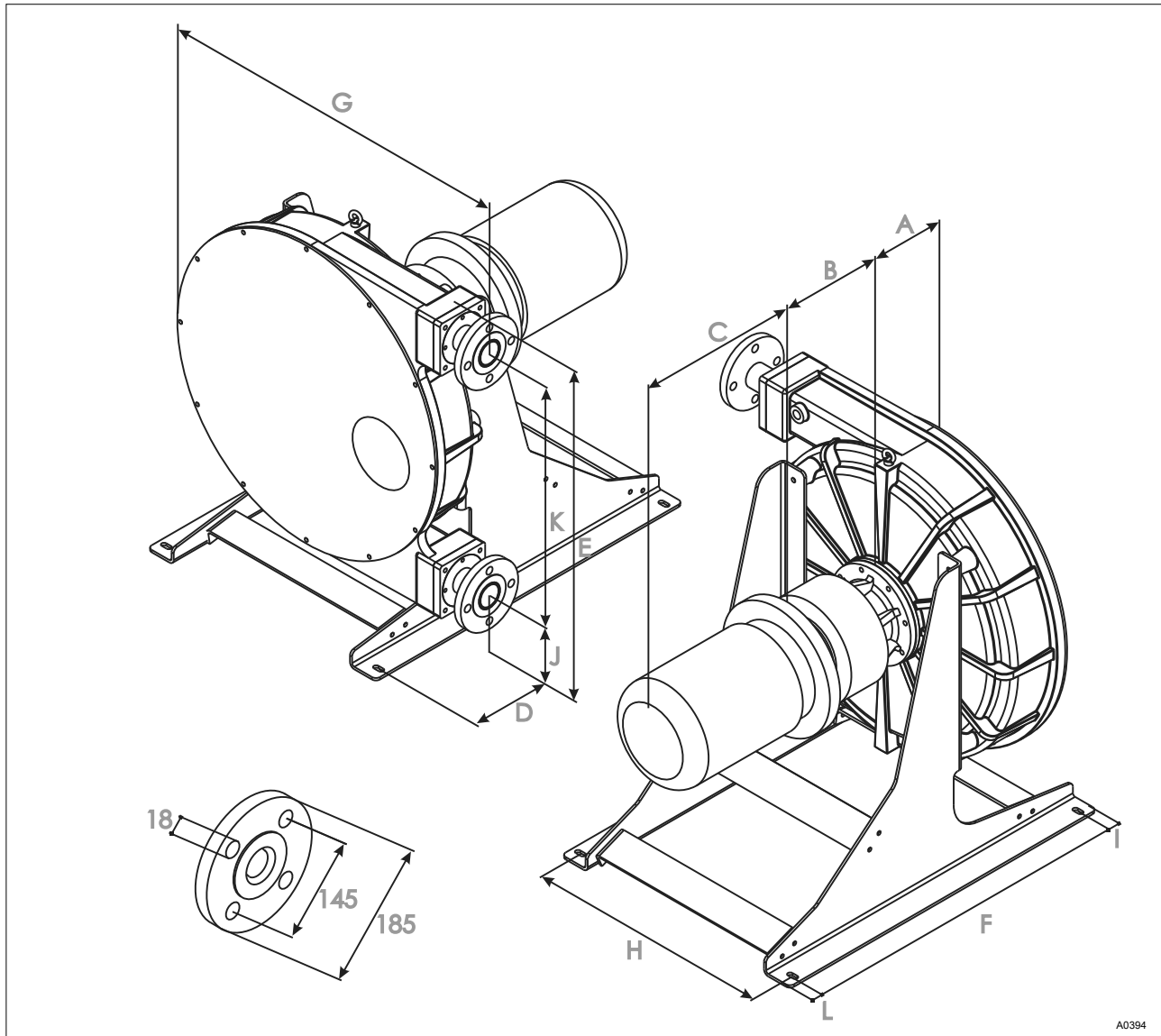

Fig. 25: Dimensions DFDa 070

A	215 mm	H	790 mm
B	*	I	40 mm
C	*	J	240 mm
D	250 mm	K	784 mm
E	1124 mm	L	40 mm
F	1065 mm	*	Dependent on selected drive
G	1100 mm		

7.6 Dimensions DFDa 080

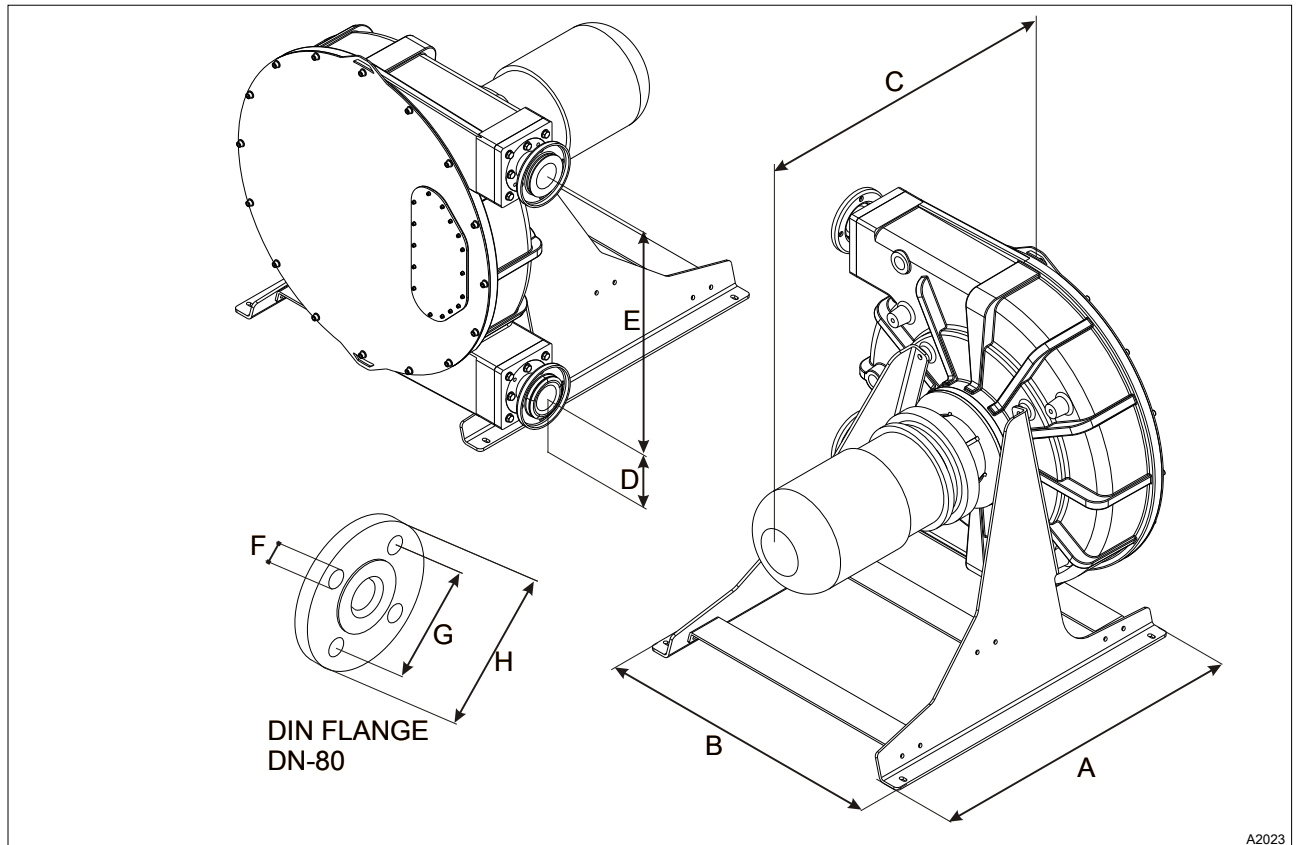
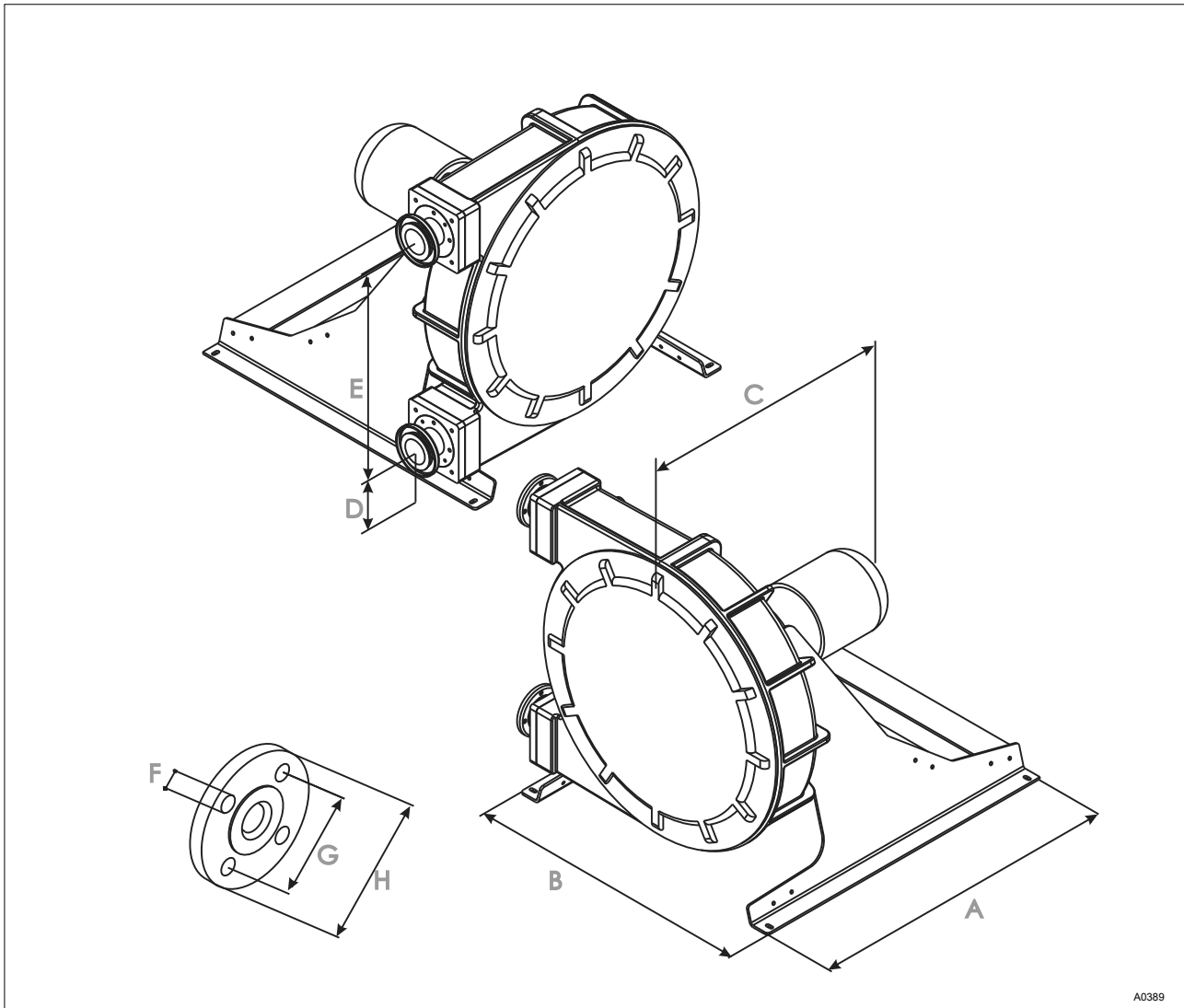

Fig. 26: Dimensions DFDa 080

A 1200 mm
B 1093 mm
C Dependent on selected drive
D 205 mm

E 850 mm
F 17.5 mm
G 160 mm
H 200 mm

7.7 Dimensions DFDa 100



A0389

Fig. 27: Dimensions DFDa 100

A	1,500 mm	F	17.5 mm
B	1,360 mm	G	180 mm
C	*	H	220 mm
D	237 mm	*	Dependent on selected drive
E	1,000 mm		

8 Technical appendices for the DFda

8.1 EC Declaration of Conformity for Machinery

In accordance with DIRECTIVE 2006/42/EC OF THE EUROPEAN PARLIAMENT AND OF THE COUNCIL, Appendix I, BASIC HEALTH AND SAFETY REQUIREMENTS, section 1.7.4.2. C.

We,

- ProMinent GmbH
- Im Schuhmachergewann 5 - 11
- D - 69123 Heidelberg,

hereby declare that the product specified in the following, complies with the relevant basic health and safety requirements of the EC Directive, on the basis of its functional concept and design and in the version distributed by us. Any modification to the product not approved by us will invalidate this declaration.

Tab. 10: Extract from the EC Declaration of Conformity

Designation of the product:	Peristaltic pump, DULCOflex
Product type:	DFAa ..., DFBa ..., DFCa ..., DFda ...,
Serial number:	see nameplate on the unit
Relevant EC directives:	EC Machinery Directive (2006/42/EC) EC EMC Directive (2004/108/EC) Compliance with the protection targets of the Low Voltage Directive 2006/95/EC according to Appendix I, No. 1.5.1 of the Machinery Directive 2006/42/EC
Harmonised standards applied, in particular:	EN 809 EN ISO 12100-1 EN ISO 12100-2 EN 60204-1 EN 60034-1 EN 60034-5 EN 60034-7 EN 61000-6-1 EN 61000-6-2
Date:	16.03.2010

The EC Declaration of Conformity is available to download on our homepage.

9 Index

A	
Action, step by step	2
Applied harmonised standards	65
Assembly and installation	26
B	
Backflowing medium	30
C	
CE	65
Commissioning	36
Correct and proper use	22
Counter measures	22
D	
Declaration of Conformity	65
Designation of the product	65
Displacement pump	24
Disposal	39
E	
Emergency stop switch	21
Enough lubricant?	37
F	
Faults	39
Functional principle	24
G	
General non-discriminatory approach	2
I	
Installation	26
L	
Links to elements or sections of these instructions or other applicable documents	2
Live parts	21
Lubricant level in the pump housing	37
M	
More symbols	2
N	
Non-discriminatory approach	2
P	
Pump dimensions	57
Pump lubricant	37
Q	
Question: How much lubricant should there be in the pump housing?	37
Question: What spare parts are available?	43
Question: What technical data is available?	57
R	
Relevant EC directives	65
Repairs	39
S	
Safety data sheet	22
Safety information	4, 21
Serial number	65
Shoes	30
Spacer plates	30
Spare parts	39
Squeezing the hose	30
Storage	26
T	
Transport	26
U	
Unauthorised access	21
Users' qualifications	5



ProMinent GmbH
Im Schuhmachergewann 5 - 11
69123 Heidelberg
Telephone: +49 6221 842-0
Fax: +49 6221 842-419
Email: info@prominent.com
Internet: www.prominent.com

986226, 5, en_GB