



Gas Chlorination Systems Series 300

Instruction Manual

All Hydro Instruments Chlorination systems are carefully designed and tested for years of safe, accurate field service. All Hydro Instruments Chlorination systems are tested, at customer specified conditions, prior to shipment. All Hydro Instruments products are made of the finest materials. To insure best operation, read these instructions carefully and completely and store them where all maintenance personnel will have access to them.

The information contained in this manual was current at the time of printing. The most current versions of all Hydro Instruments manuals can be found on our website: www.hydroinstruments.com

E300 Rev. 6/15/2023

Hydro Gas Chlorination Systems Series 300 Operation & Maintenance Manual

Table of Contents

I. SAFETY INFORMATION	3
II. DESIGN AND INSTALLATION NOTES	3
III. SYSTEM INSTALLATION	4
1. Installation of Hydro Ejector	5
2. Installation of Hydro Vacuum Regulator	5
3. Connecting Vacuum Lines	6
4. Units with Switchover Modules and/or Remote Meters.....	7
IV. CHLORINATION SYSTEM VACUUM TEST	7
V. START UP OF CHLORINATION	8
VI. SHUT DOWN PROCEDURE	8
VII. RATE VALVE OPERATION	8
VIII. TROUBLESHOOTING	9
1. Pressurized Leaks.....	9
2. No Chlorine Feed	9
APPENDIX: SERVICING THE HYDRO INSTRUMENTS SYSTEM	
A-1. VACUUM REGULATOR	10
1. Cleaning the Rate Valve.....	10
2. Cleaning the Meter Tube.....	10
A-2. EJECTOR/CHECK VALVE ASSEMBLY	11
1. Loss of Vacuum at the Ejector.....	11
2. Servicing the Ejector Check Valve Assembly	11
A-3. SWITCHOVER MODULE	12
1. Operation of the Module.....	12
2. Servicing the Module.....	12
DRAWINGS	14
1. Vacuum Regulators	14-25
2. Complete Ton Yoke and Inlet Assembly	26-28
3. Micro Switches	30-31
4. Ejectors	32-39
5. Remote Meters.....	40-45
6. Switchover.....	46-47
NOZZLE SIZING CHARTS	48-50
NOZZLE TABLES	51-53

SECTION I: SAFETY INFORMATION

TAKE CARE WITH CHLORINE!

1. Always keep chlorine cylinders in an upright position with the valve cap screwed on tight before moving full or empty cylinders. Cylinders and ton containers must be moved with care.
2. A safety chain must be placed around the cylinder and secured to a wall. Spare full cylinders should also be secured carefully. In earthquake prone areas, ton containers can also be strapped to the floor to secure them in place.
3. For best operation and safety, the **vacuum regulators and cylinder or ton containers should be protected from the elements including direct sunlight.**
4. **Never** place heaters or heat lamps directly on a cylinder. Use fans to increase air flow past chlorine cylinders and ton containers if it is desired to increase the gas withdrawal rate.
5. **Ammonia gas should NOT be stored or fed in the same room with chlorine.** Contact of the gases may result in an explosive mixture.
6. All chlorine gas installations should include chlorine gas leak detector systems for added safety.
7. Refer to Hydro Instruments Chlorine Handling Manual and other technical guides for more detailed guidance.
Refer to the technical literature section of the Hydro Instruments website to obtain all such literature.

IMPORTANT NOTE:

*Pressurized chlorine gas manifolds should be avoided when possible. These pressurized manifolds increase the risk of a pressurized chlorine gas leak. Hydro Instruments vacuum regulators are designed to mount directly onto the valve of chlorine cylinders and ton containers. **Direct cylinder or ton container mounting is the easiest and safest configuration to operate and maintain.** With this configuration, the chlorine gas flows under vacuum everywhere beyond the one pressure point at the chlorine cylinder valve.*

SECTION II: DESIGN AND INSTALLATION NOTES

1. **The “all vacuum” system** means that system will shut off at the vacuum regulator, should the vacuum line be broken, if water is stopped for any reason, or if the vacuum regulator is physically damaged.

2. Choosing a **feed capacity:**

Vacuum regulator SIZE SHOULD BE ON MAXIMUM POSSIBLE FLOW.

Imperial Units:

$$\begin{array}{ccccccc} \text{GPM} & \times & 0.012 & \times & (\text{PPM}) \text{ Dosage} & = & \text{PPD} \\ \text{Gallons Per Minute} & & & & \text{Parts Per Million} & & \text{Pounds Per Day (Cl}_2\text{)} \end{array}$$

Example: 600 GPM x 0.012 x 3 PPM = 21.6 PPD

In this example a Hydro Instruments 50 PPD vacuum regulator would be adequate.

Metric Units:

$$\begin{array}{ccccccc} \text{M}^3/\text{HR} & \times & & (\text{PPM}) \text{ Dosage} & = & \text{GR}/\text{HR} & \\ \text{Cubic Meters Per Hour} & & & \text{Parts Per Million} & & \text{Grams Per Hour} & \\ (\text{Cl}_2) & & & & & & \end{array}$$

3. **TOTAL BACK PRESSURE** is the pressure in the pipeline to be chlorinated plus the friction losses in the solution line between the ejector and the point of injection at the pipeline. Ejectors capable of operating with back pressures up to 300 Psig (20 bar) are available.

4. It is preferable to locate the ejector at the point of solution injection in order to minimize **solution lines**. Friction losses in the solution line will **increase the ejector back pressure**. To reduce the friction losses, increase the solution line internal diameter and limit the number of flow restrictions and turns. Also be sure that the solution line material is resistant to **the highly concentrated chlorine mixture**. **Avoid or minimize solution lines wherever possible.**
5. The only connection between the ejector and the vacuum regulator is the Hydro Instruments specified black polyethylene tubing which carries the vacuum (originating at the ejector) to the vacuum regulator, allowing the system to operate. Up to 100 feet of polyethylene tubing between vacuum regulator and ejector is standard. For longer distances consult Hydro Instruments and review the Vacuum Tubing and Piping (Gas) guide document.

Torque Specifications

Item	Min. Inch/lbs.	Max. Inch/lbs.
Yoke bolts	20	25
Body bolts	20	25
Meter block bolts	20	25
Meter inlet plug	10	15
Meter dummy plug	7	10
Vacuum fittings	15	20
Item	Min. Foot/lbs.	Max. Foot/lbs.
Ton ironworks flange bolts	20	25
Ton ironworks closed yoke adapter	72	75
Yoke half-dog bolt	20	25

SECTION III: SYSTEM INSTALLATION

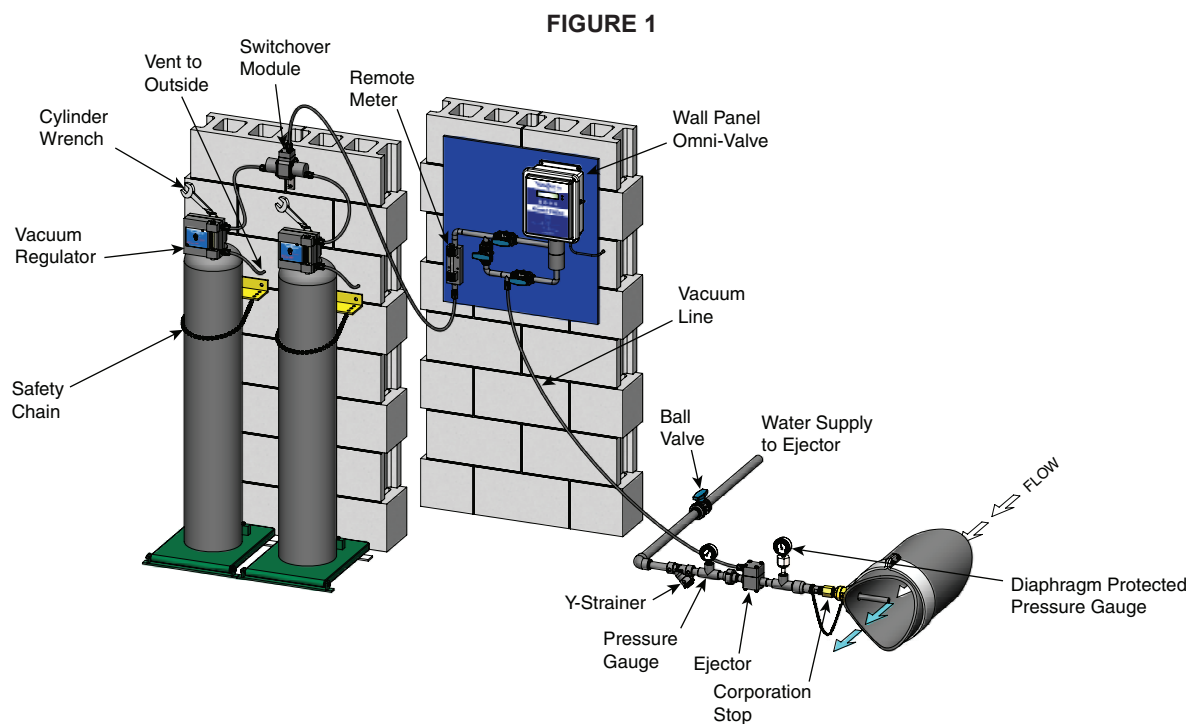

A typical Hydro Instruments installation injecting chlorine into a pipe line using city water.

(I) INSTALLATION OF HYDRO INSTRUMENTS EJECTOR (Refer to Figure 1)

1. Installation of HYDRO INSTRUMENTS EJECTOR:
 - a. Remove the diffuser from the ejector assembly and place four wraps of Teflon tape on diffuser threads.
 - b. **Do Not** install diffuser into pipe line when assembled with ejector.
 - c. Turn diffuser by hand into NPT threads of pipe line ($\frac{3}{4}$ " or $1\frac{1}{4}$ " NPT). Place wrench on diffuser and tighten **one half turn maximum**.
 - d. Reconnect diffuser to ejector making sure OH-BUN-214 O-Rings are on each side of nozzle and diffuser.
2. Testing of ejector. (*Note: The vacuum regulator should still be in the shipping case.*)
 - i. Piping hook up to ejector (Refer to Figure 1 and **Servicing Section in this Manual**).
 - a. Ejector should be installed down stream at a sufficient distance so that chlorinated water is not re-circulated through the booster pump. Pump suction should be 5 feet away from ejector injection point. On larger pipe diameters of 6 inches or greater a distance of 10 times the pipe diameter should be maintained so that chlorinated water is not recirculated through the booster pump.
 - b. On the water inlet side to the ejector nozzle the following should be installed: a water inlet valve, Y-strainer, and a pressure gauge. On the discharge side of the ejector a diaphragm protected pressure gauge appropriate for use with highly chlorinated water should be installed.
 - ii. Testing for sufficient pump pressure to operate ejector. Also checking that booster pump (if applicable) operating in the proper direction.

Note 1: Ejector must have some back pressure to prevent jetting. (Jetting causes loss of vacuum)

Note 2: When chlorinating into a contact chamber a tee should be installed on the solution line with a vacuum breaker to prevent siphoning.

 - a. If operating with city water pressure (no booster pump), open the water inlet valve to the ejector and feel for suction (with your finger) at the fitting on the top of the ejector.
 - b. Each ejector nozzle/diffuser combination has corresponding performance charts that indicate the required water flow and pressure required to operate at any given back pressure. If sufficient water flow and pressure are being supplied, then there should be a strong suction at the fitting on the top of the ejector. Feel for suction (with your finger) at the fitting on the top of the ejector if no vacuum gauge is available.
 - c. If the ejector has tested satisfactorily continue on to the next step (Mounting the Vacuum Regulator).

(II) INSTALLATION OF HYDRO INSTRUMENTS VACUUM REGULATOR

NOTE: The chlorine cylinder valve is still closed. Do not turn on until instructed to do so.

1. Make sure that a safety chain is secured around chlorine cylinder or if using ton containers that the ton container is properly supported.
2. Remove the cylinder protection cap from the chlorine cylinder or ton container.

IMPORTANT: If using ton containers, make sure that the valves on the ton container are vertically aligned and only connect to the top valve for gas withdrawal.

FIGURE 2

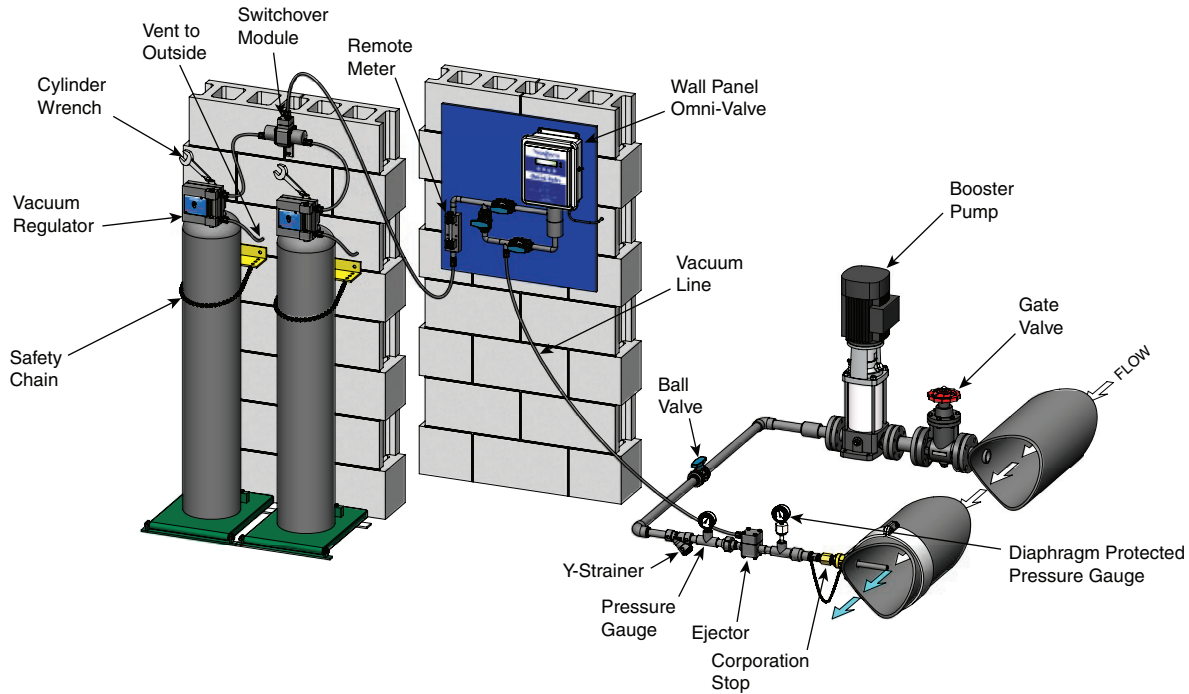

A typical Hydro Instruments installation injecting chlorine into a pipe line using a centrifugal pump. Note the location of gate and ball valves for easy Y-strainer cleaning and practical pump maintenance.

NOTE: Pump suction should be 5 feet away from ejector injection point. On larger pipe diameters of 6 inches or greater a distance of 10 times the pipe diameter should be maintained so that chlorinated water is not recirculated through the booster pump.

NOTE: Pump suction and ejector must be from the side of pipeline, not from top of the main.

3. Examine the vacuum regulator for obvious damage.
4. Remove all materials used for shipping purposes.

IMPORTANT: If it is a direct ton mounted ton container, make sure to evenly tighten the two bolts BTH-STA-139 according to the label with red letters that is on the vacuum regulator.

5. Place a new lead gasket over vacuum regulator inlet assembly.
6. While placing lead gasket on vacuum regulator make sure that the filter material has not fallen out of inlet assembly. (This filter is necessary to remove particles that may precipitate out of chlorine.) Filters must be changed as necessary. Inspect the filters periodically and keep in mind that if vacuum level starts to increase or feed rate is restricted, then the filter might be clogged and in need of replacement.

7. Mount vacuum regulator on cylinder valve being sure the yoke screw is backed out far enough for sufficient clearance. While tightening the yoke screw be certain that the lead gasket stays in place. Excessive tightening can damage gasket and/or yoke screw. **DO NOT USE EXCESSIVE FORCE.**

IMPORTANT: Ton mounted vacuum regulators mount on the top valve only. They include a drip leg and heater. The heater must be plugged in and powered on at least 15 minutes prior to opening the ton container valve. The heater must always be powered on while in service.

(III) CONNECTING VACUUM LINES BETWEEN VACUUM REGULATOR AND EJECTOR AND VACUUM REGULATOR VENT TO OUTSIDE (Refer to Figures 1 and 2)

1. The upper connector on right top of vacuum regulator is for vacuum line tubing to ejector.

2. Connect vent tubing to second connector on the vacuum regulator and vent to safe area outside of building. (Place bug screen outside on end of vent tubing.)

NOTE: Vent lines should be lower than the vacuum regulator. Do not connect vent lines from multiple vacuum regulators into a common vent – vent lines must remain separate. If desired, vent lines can be terminated at a scrubber intake duct or a vent arrestor device.

(IV) REMOTE METERS/WALL PANEL OMNI-VALVES & SWITCHOVER MODULES (Refer to Figures 2 & 3)

1. **Switchover modules:** (Gas flow is from bottom/side to top from one side only at a time)
Make vacuum tubing connections as shown in Figures 1, 2 and 3.
2. **Remote Meters:** (Gas flow is from bottom to top through the tube)
Make vacuum tubing connections as shown in Figures 1, 2 and 3.

FIGURE 3

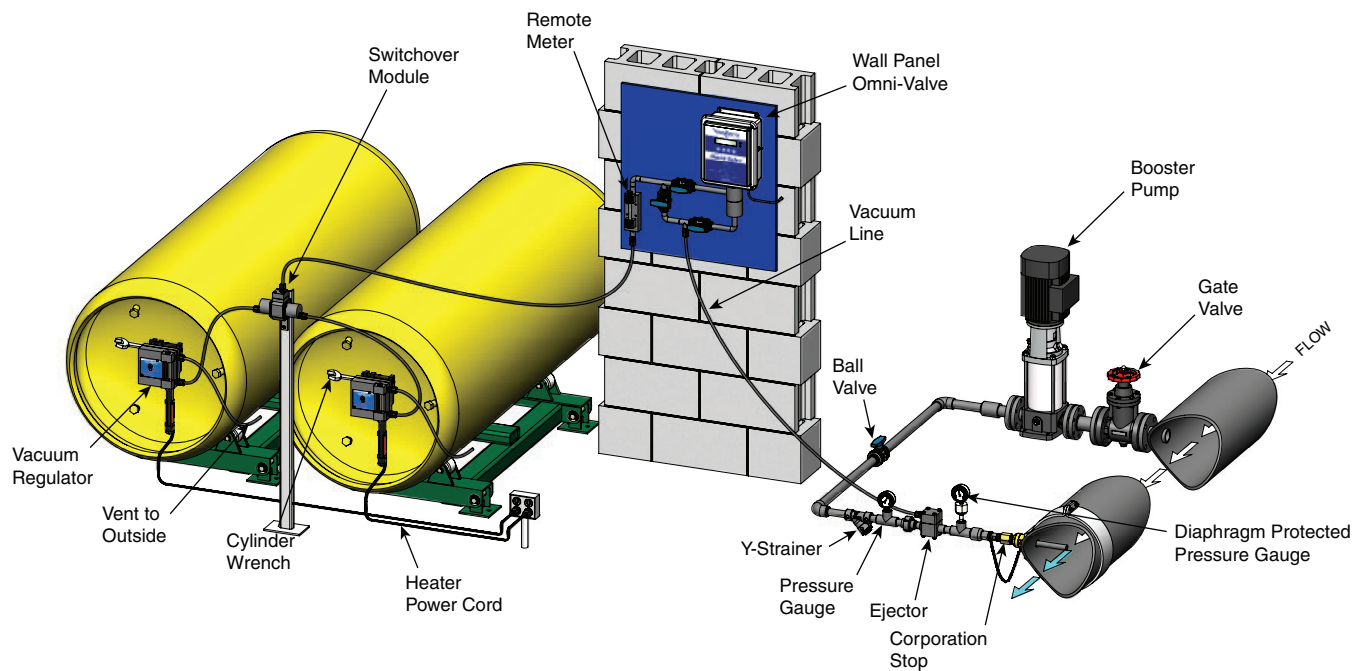

A typical Hydro Instruments Switchover System injecting chlorine into a pipeline using a centrifugal pump.

NOTE: Pump suction and ejector must be from the side of the pipeline, not from the top of the line.

SECTION IV: CHLORINATION SYSTEM VACUUM TEST

1. **Do Not** open chlorine cylinder valve until vacuum test is satisfactorily completed.
 - a. **Vacuum Test**
With the chlorine cylinder still closed, start the ejector booster pump and the meter tube ball should drop to the bottom within 30 seconds. At this time the feed rate adjustment valve should be open. If the ball continues to bounce there is a vacuum leak in the system. Check the lead gasket seal at the cylinder valve and all tubing connections. (The tube fittings should be hand tight. It is not necessary to use pliers or a wrench on these fittings.)
 - b. If the ejector is operating properly (pulling sufficient vacuum) the red indicator on the front of the vacuum regulator should be showing.
 - c. Turn off water supply to ejector.

- d. Wait 5 to 10 minutes with water supply off. The reset knob should turn freely all the way around and the indicator should continue to show red. (If red continues to show, the system is vacuum tight.)
- e. If the system is vacuum tight proceed to the next step.
- f. Disconnect vacuum tubing at top of vacuum regulator to allow air to enter the system. Reconnect tubing.
 - (1) Turn the reset on the front of the vacuum regulator and it should not show red.

SECTION V: START UP OF CHLORINATION

Material necessary: A small plastic squeeze bottle, 1/3 full of ammonia, for detecting chlorine leaks. When ammonia fumes contact chlorine gas a visible white smoke is produced.

IMPORTANT: If using direct ton container mounted vacuum regulators ensure that the BTH-STA-139 bolts were checked and tightened and that the heater was plugged in and allowed to heat up for at least 15 minutes prior to starting this procedure.

1. Open chlorine cylinder valve 1/4 turn and **close immediately**.
2. Squeeze ammonia bottle at gasket and yoke assembly area and around rate valve bonnet: if no smoke appears the seals are tight and it is OK to proceed to the next step. (Do not intentionally squirt liquid ammonia onto the lead gasket connection or elsewhere. If liquid ammonia does get onto the equipment, wipe it up using a dry towel.)
3. Open chlorine cylinder valve 1/4 turn, leave open, and **recheck for chlorine leaks**. (1/4 turn open of the cylinder valve is all that's required. The reason we specify 1/4 turn is that when you turn it off you know it should close with 1/4 turn. In an emergency you can shut it off quickly and safely. The wrench stays on the cylinder valve while cylinder is open.)
4. Turn on water supply or booster pump to ejector and set rate valve to desired flow rate. Read flow rate at center of ball on meter tube scale and at the top edge for machined floats.
5. Be aware that the rate valve is not a shut off valve: it is a flow rate control only. **To shut off chlorine feed close the chlorine cylinder valve/ton container valve.**

SECTION VI: SHUT DOWN PROCEDURE

IMPORTANT!: This procedure of shut down must be followed before a vacuum regulator is removed from a cylinder or ton container.

1. Close all chlorine cylinder valves or ton container valves while the ejector is still operating.
2. Wait for the ball to rest at the bottom of the meter tube and the indicator flag on the vacuum regulator to show red.
3. Shut off the water supply to the ejector.

SECTION VII: RATE VALVE OPERATION

Turn the rate valve counter-clockwise to open it completely. Further turns will completely remove the rate valve from the assembly, which will cause a loss of Cl₂ feed. **(See Appendix for servicing instructions.)**

The O-ring seal for the rate valve is locked in place under the valve bonnet and does not come out when the rate valve is pulled out of the bonnet.

PREVENTATIVE MAINTENANCE NOTE: Rate valves which are not exercised frequently may experience a build up of a white powdery substance which precipitates out of the chlorine gas. In order to avoid this build up, which can cause the rate valve to become stuck in place, it is recommended that the rate valve be periodically exercised. See Appendix for rate valve maintenance instructions.

SECTION VIII: TROUBLESHOOTING

(I) PRESSURIZED LEAKS

1. Pressurized chlorine leaks are a safety hazard to life and equipment and should be corrected immediately. When searching for this type of leak there are basic safety rules to follow.
 - a. Air breathing pack should be readily available and personnel should know how to use it properly.
 - b. Exhaust fan switch should be located near outside entrance with an additional alternate outside switch appropriately located.
 - c. Chlorine cylinder wrench should remain on the cylinder whenever cylinder is open.
 - d. Plastic squeeze bottle $\frac{1}{3}$ full of household ammonia.
 - e. Buddy system used (two people capable of operating system).
2. If a leak is detected the following should be checked first:
 - a. The **lead gasket** between the chlorine cylinder valve and the vacuum regulator inlet assembly.
 - i. Tighten the half dog screw on the vacuum regulator yoke assembly which is used to secure the inlet assembly to the chlorine cylinder valve. (Do not use excessive force.)
 - ii. Always use a new lead gasket. It is recommended to obtain gaskets through Hydro Instruments to be certain of size and quality.
 - b. **Chlorine cylinder or ton container valve packing.**
 - i. Tighten the cylinder valve with care, not excessively! Close the valve if problem persists and notify your chlorine supplier.
 - ii. If valve is the problem try to move cylinder with a high degree of safety to an outside location. (**Never** attempt to place cylinder in water as this will only increase the leak and the cylinder may float to the surface.) If Emergency Repair Kit A or B is available and personnel are trained to use it, then this can also be used to temporarily stop the leak.
 - c. Chlorine leaking out the vent due to the **inlet safety shut off valve** having dirt on the valve seat.
 - i. Close the **chlorine cylinder or ton container valve**.
 - ii. Wait until the metering ball drops to zero on the flow tube.
 - iii. Turn off water supply to ejector.
 - iv. Now remove the vacuum regulator from the cylinder or ton container valve provided that the red indicator is showing no chlorine pressure. (Red should be showing.)
 - v. See Appendix for inlet safety shut off valve servicing instructions.
 - vi. After servicing and remounting vacuum regulator with a new lead gasket, perform a vacuum test **before** you open the cylinder or ton container valve valve. **See "Chlorination System Vacuum Test"**.

(II) NO CHLORINE FEED

Possible causes:

1. No vacuum being produced by ejector.
 - a. Remove poly tubing from ejector fitting and place your finger on it; you should feel a suction.
 - b. If you feel no suction (vacuum) check in this order:
 - i. **Nozzle (See Appendix):** Turn off water supply and remove nozzle from ejector.

- (1) It may be clogged with a stone or other foreign matter. Flush out or run pipe cleaner through only.
- (2) If there is a build-up of rust, iron, or manganese, place the nozzle in a Muriatic acid for five minutes and rinse with water. If you see a black syrup substance you may find it necessary to clean the nozzle on a preventative maintenance schedule.

ii. **Inlet Water Supply.**

iii. Reduced city water pressure.

iv. Y strainer needs cleaning.

v. Booster pump cavitating (lost its prime).

vi. Booster pump insufficient boost due to wear or single phasing due to loss of one leg of power.

vii. Booster pump may have flooded suction.

2. Chlorine flow blocked at vacuum regulator inlet assembly.

a. The **Inlet filter could be clogged.**

3. **Out of Chlorine.**

a. The scale would read 150 lbs. lighter than when the cylinder was new or 2,000 lbs. lighter for ton containers.

b. Flow ball would be at zero and RED indicated on front of vacuum regulator.

APPENDIX A – SERVICING THE HYDRO INSTRUMENTS SYSTEM

SECTION A-1: VACUUM REGULATOR

(I) CLEANING THE RATE VALVE

1. Unscrew the rate valve knob and stem (by hand) completely out of the top meter block.
2. In low capacity systems (10 PPD or below) check to see if the point of the valve stem is broken or bent. If it is damaged it must be replaced.
3. Replace O-Rings on the rate valve stem.
4. Lubricate the new O-Rings lightly with Flourolube grease before replacing the rate valve and knob into the top meter block.

(II) CLEANING THE METER TUBE

1. While holding the glass meter tube (to prevent it from falling) unscrew the inlet plug at the base of the bottom meter block, until the meter tube can be removed.
2. Remember to be careful not to lose the stops or ball in the following steps.
3. Remove the white stops at either end of the tube (you could use a paper clip).
4. Soak the tube in warm water with a cleaner like lime away or Muriatic Acid. Also, brush the inside of the tube with a pipe cleaner.

NOTE: Always follow safety precautions with Muriatic Acid and other chemicals.

5. Dry the meter tube and reinstall the ball and stops.

6. It is recommended that new meter tube gaskets be used when reinstalling the meter tube.
7. Remove the inlet plug completely and inspect the O-Rings. If it has been more than 12 months since they were changed or if there is any noticeable damage, the O-Rings should be replaced.
8. Reinstall the inlet plug, meter gaskets and meter tube, making sure to center the tube on the top and bottom meter gaskets.
9. Tighten the inlet plug with reasonable force to make a seal. Do not use excessive force.

NOTE: All other vacuum regulator repairs should be done by the factory or authorized repair personnel.

WARNING: *If the vacuum regulator leaks gas out the vent or any other place on the body the problem is most likely caused inside the vacuum regulator inlet capsule assembly VRH-469-501. It is not recommended that the vacuum regulator inlet capsule assembly be disassembled by any untrained personnel because if it is not done properly then dangerous leakage of pressurized chlorine gas could result.*

SECTION A-2: EJECTOR/CHECK VALVE ASSEMBLY

(I) LOSS OF VACUUM AT THE EJECTOR: If vacuum is lost at the ejector and water supply is sufficient, then the nozzle is most likely clogged, broken or loose. Before working on the ejector it must first be isolated so that water will not leak when the ejector is removed.

1. First detach the intake side (nozzle) of the ejector from the pipe line.
2. For 100 PPD or lower ejectors rotate the complete ejector body counter clockwise. This loosens the threaded portion of the nozzle from the diffuser. It also eliminates the need for pliers on the nozzle which could damage the plastic.
3. Inspect the nozzle for:
Pipe scale, stones, dirt, etc...
Build-up of iron, manganese, calcium, etc...
4. The nozzle should be soaked and brushed with warm water mixed with a cleaner like Muriatic Acid.
NOTE: TAKE CARE NOT TO SCRATCH OR ATTEMPT TO MODIFY THE ORIFICE IN ANY WAY.
5. Using two new OH-BUN-214 O-Rings the ejector can now be reassembled.

When reassembling the ejector the nozzle and diffuser should be screwed together hand tight leaving the ejector body 90 degrees to the left of its final position. Once the nozzle and diffuser are hand tight, the ejector can then be turned the final 90 degrees.

WARNING: *Do not use excessive force in tightening the nozzle, diffuser and ejector assembly. The ejector is constructed of PVC and excessive force can break the parts.*

(II) SERVICING THE EJECTOR CHECK VALVE ASSEMBLY: If water leaks back into the system, this means that the ejector check valve has failed. This could be caused by incorrect assembly, a failed gasket, O-Ring or diaphragm, or foreign material lodged in the check valve.

1. For gasket check valve ejectors, carefully remove the raised seat screw in the center top of the ejector body with a pair of pliers. Under this plug is a rubber gasket. Replace the seat if it is damaged or if the hole is plugged shut.
2. For gasket check valve ejectors, reinstall the seat screw tightening with pliers. Be careful not to over tighten using only reasonable force.
3. Remove the four bolts holding the ejector body together.

4. Inside you will find a diaphragm assembly and a spring.
5. The diaphragm assembly can usually be unscrewed by hand. If it is too tight, carefully try large jaw pliers or a vice. Note that a plastic support diaphragm is on the top side of the rubber diaphragm. The purpose is to protect the softer rubber diaphragm in installations with high pressure.
6. Inspect the rubber diaphragm for holes or weak points.
 - a. For O-ring check valves, inspect the OH-CEM-210 O-Ring. Replace if damaged.
7. Reassemble the diaphragm assembly, preferably with a new rubber diaphragm.
8. Install the assembly in the recess between the ejector body halves being careful to install the spring properly below the assembly.

SECTION A-3: SWITCHOVER MODULE

(I) OPERATION OF THE MODULE

GENERAL: This device requires no outside setting or adjustment. The switchover module allows gas to flow from one of the two intake ports at a time, keeping the other sealed. It will continue to feed from first side until the vacuum level rises sufficiently (in the event of an empty cylinder or closing of the cylinder valve), at which time an internal spring loaded mechanism automatically switches to open the second intake port and to close the first intake port.

NOTE: *In low capacity systems where the feed rate is less than 10 PPD or the time between switching is more than two weeks, it is recommended that the module be “exercised” weekly. If the module is left in one position for long periods of time, it may have a tendency to stick in one position. To exercise the module it can be disconnected from both vacuum regulators with the ejector still connected and operating. Use a finger or thumb to close the open intake port of the module until it switches to feed from the other port. Repeat this process 5 to 10 times.*

(II) SERVICING THE MODULE

GENERAL: If the module does not operate correctly first try exercising it as described in the last paragraph. If this does not work the unit must be disassembled.

1. Remove the four screws that secure the top cap onto the main body.
2. Remove the four screws that secure each of the side caps onto the main body.
3. Remove the diaphragm assemblies and the toggle mechanism noting their orientations for reassembly.
4. Inspect the guide pin to ensure that it is free of dirt or burrs. If not clean and polish it with alcohol until it is able to slide freely.
5. Inspect the O-Ring seats on the diaphragm assemblies. Ensure that they are free of any residue and should be cleaned with alcohol being careful not to scratch them.
6. Replace the O-Rings unless they are less than 12 months old and unless they are in perfect condition.
7. Inspect the diaphragms to ensure that they are free of tears or holes. If they are not in good condition, they should be replaced.
8. Reassemble the module in reverse order.

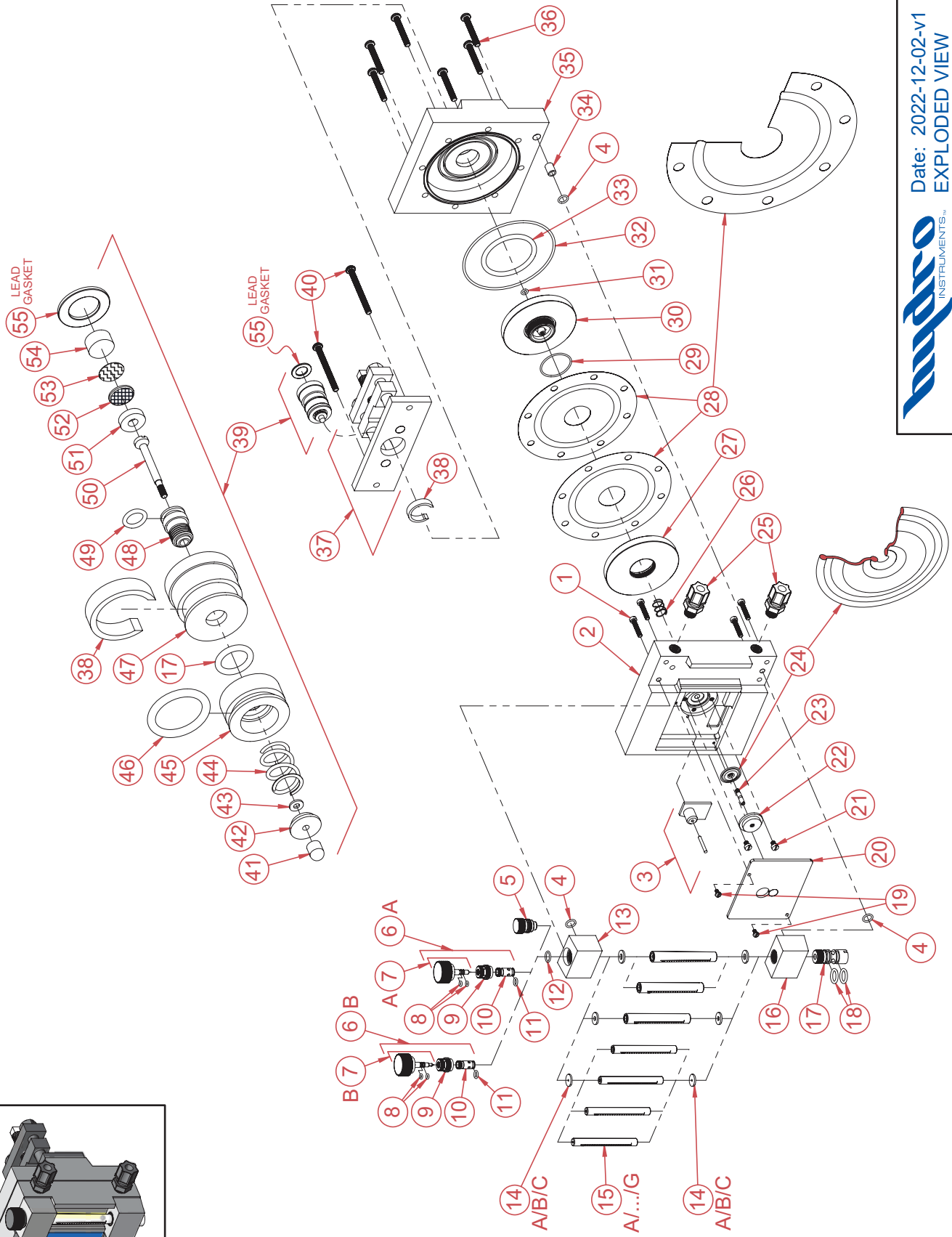
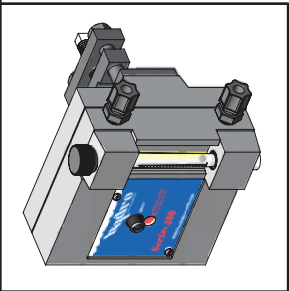

Item No.	Description	Quantity	Part No.	Item No.	Description	Quantity	Part No.
1	10-24 x 1" Bolt	4	BTH-STA-126	25	PM 3/8" Tubing Connector	2	BKF-64
2	Front Body	1	VRH-107-250	26	Spring	1	SPH-100-000
3	Flag Assembly	1	VRH-445-500	27	Diaphragm Front Plate	1	VRH-269-500
4	PM O-Ring	3	OH-VIT-012	28	PM Set of Two Diaphragms	1	DIH-106-500
5	Bonnet Plug, 250 PPD	1	PLH-175-250	29	PM O-Ring	1	OH-VIT-028
6A	Rate Valve Assembly, 10 PPD	1	RVH-118-002V	30	Diaphragm Back Plate	1	VRH-363-500
6B	Rate Valve Assembly, 100 PPD	1	RVH-118-003	31	PM O-Ring	1	OH-VIT-009
7A	Rate Valve Stem & Knob, 10 PPD	1	RVH-659-002V	32	PM O-Ring	1	OH-VIT-156
7B	Rate Valve Stem & Knob, 100 PPD	1	RVH-659-003	33	O-Ring	1	OH-VIT-331
8	PM O-Ring	2	OH-VIT-006	34	Flow Tube	1	VRH-162-500
9	Rate Valve Bonnet, 250 PPD	1	RVH-124-200	35	Back Body	1	VRH-160-200
10	Rate Valve Sleeve	1	RVH-125-003	36	1/4-20 x 1 3/4" Body Screw	6	BTH-STA-124
11	PM O-Ring	1	OH-VIT-010	37	Yoke Assembly	1	VRH-346-500
12	PM O-Ring	1	OH-VIT-110	38	* Retainer Clip	1	VRH-142-500
13	Top Meter Block	1	MBH-110-100	39	Inlet Valve Capsule Assembly	1	VRH-469-501
14A	PM Meter Gasket, 10 PPD	2	GAH-VIT-101	40	1/4-20 x 2 3/4" Back Plate Screw	2	BTH-STA-125
14B	PM Meter Gasket, 25 PPD	2	GAH-VIT-102	41	Vent Plug	1	VRH-111-500
14C	PM Meter Gasket, 100 PPD	2	GAH-VIT-103	42	Spring Retainer	1	VRH-183-500
15A	Meter Tube, 0.6 PPD	1	MTH-108-006	43	Spring Holder	1	VRH-113-500
15B	Meter Tube, 1.5 PPD	1	MTH-108-0015	44	Inlet Spring	1	SPH-104-000
15C	Meter Tube, 4 PPD	1	MTH-108-004	45	PM Seal Plug	1	VRH-182-500
15D	Meter Tube, 10 PPD	1	MTH-108-010	46	PM O-Ring	1	OH-VIT-212
15E	Meter Tube, 25 PPD	1	MTH-108-025	47	Inlet Capsule	1	VRH-141-501
15F	Meter Tube, 50 PPD	1	MTH-108-050	48	PM Valve Seat	1	VRH-110-500
15G	Meter Tube, 100 PPD	1	MTH-108-100	49	PM O-Ring	1	OH-VIT-011
16	Bottom Meter Block	1	MBH-109-100	50	Inlet Valve	1	VRH-112-500
17	Meter Inlet, 250 PPD	1	MIH-140-200	51	PM Filter Stop	1	VRH-184-500
18	PM O-Ring	3	OH-VIT-112	52	PM Inlet Screen	1	VRH-101-500
19	6-32 x 5/16" Screw	2	BTH-STA-127	53	PM Filter Pad	1	VRH-457-500
20	Face Plate	1	VRH-441-250	54	PM Teflon Filter (100 PPD max)	1	VRH-456-100
21	10-24 x 3/16" PVC Screw	2	BTH-STA-128	55	Lead Gasket	1	GAH-LED-111
22	Seal Cover	1	VRH-137-500	PM	Part and Maintenance Kit	1	KTH-100-VRC
23	Guide Pin	1	VRH-140-500	*	Part of VRH-469-501 Assembly		
24	PM Sealing Diaphragm	1	DIH-102-500				



VACUUM REGULATOR

Date: 2022-12-02-v1

BILL OF MATERIALS

Dwg. No. VRH-100-CL2, BOM

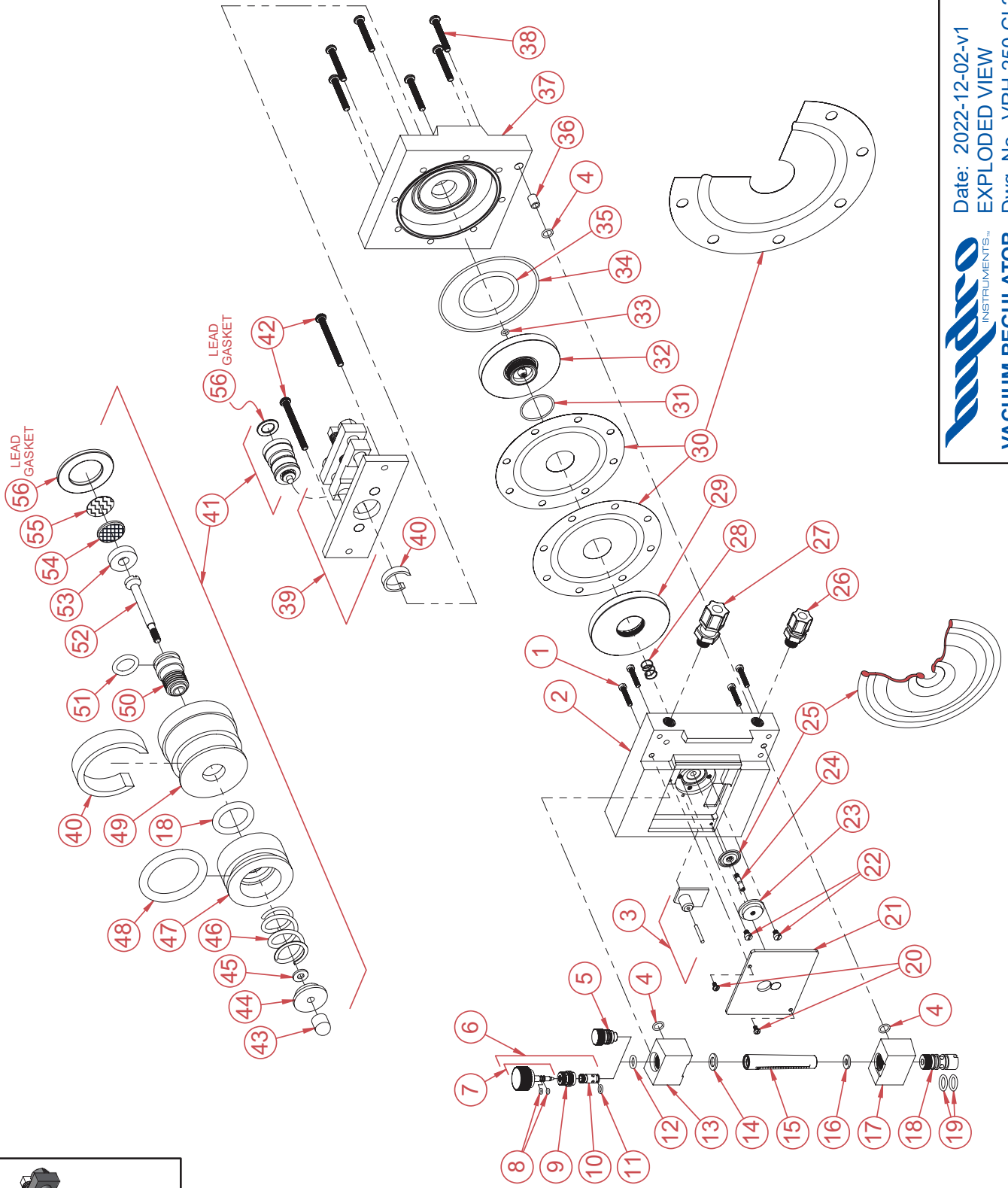
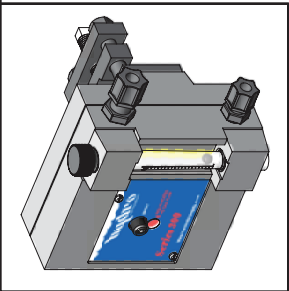

Item No.	Description	Quantity	Part No.	Item No.	Description	Quantity	Part No.
1	10-24 x 1" Bolt	4	BTH-STA-126	30	PM Set of Two Diaphragms	1	DIH-106-500
2	Front Body	1	VRH-107-250	31	PM O-Ring	1	OH-VIT-028
3	Flag Assembly	1	VRH-445-500	32	Diaphragm Back Plate	1	VRH-363-500
4	PM O-Ring	3	OH-VIT-012	33	PM O-Ring	1	OH-VIT-009
5	Bonnet Plug, 250 PPD	1	PLH-175-250	34	PM O-Ring	1	OH-VIT-156
6	Rate Valve Assembly	1	RVH-118-004	35	O-Ring	1	OH-VIT-331
7	Rate Valve Stem & Knob	1	RVH-659-004	36	Flow Tube	1	VRH-162-500
8	PM O-Ring	2	OH-VIT-006	37	Back Body	1	VRH-160-200
9	Rate Valve Bonnet	1	RVH-124-200	38	1/4-20 x 1 3/4" Body Screw	6	BTH-STA-124
10	Rate Valve Sleeve	1	RVH-125-003	39	Yoke Assembly	1	VRH-346-500
11	PM O-Ring	1	OH-VIT-010	40	* Retainer Clip	1	VRH-142-500
12	PM O-Ring	1	OH-VIT-110	41	Inlet Valve Capsule Assembly	1	VRH-469-501-1
13	Top Meter Block	1	MBH-117-250	42	1/4-20 x 2 3/4" Back Plate Screw	2	BTH-STA-125
14	PM Top Meter Gasket	1	GAH-VIT-104	43	Vent Plug	1	VRH-111-500
15	Meter Tube	1	MTH-108-250	44	Spring Retainer	1	VRH-183-500
16	PM Bottom Meter Gasket	1	GAH-VIT-103	45	Spring Holder	1	VRH-113-500
17	Bottom Meter Block	1	MBH-116-250	46	Inlet Spring	1	SPH-104-000
18	Meter Inlet, 250 PPD	1	MIH-140-200	47	PM O-Ring	1	OH-VIT-212
19	PM O-Ring	3	OH-VIT-112	48	PM Seal Plug	1	VRH-182-500
20	6-32 x 5/16" Screw	2	BTH-STA-127	49	Inlet Capsule	1	VRH-141-501
21	Face Plate	1	VRH-441-250	50	PM Valve Seat	1	VRH-110-500
22	10-24 x 3/16" PVC Screw	2	BTH-STA-128	51	PM O-Ring	1	OH-VIT-011
23	Seal Cover	1	VRH-137-500	52	Inlet Valve	1	VRH-112-500
24	Guide Pin	1	VRH-140-500	53	PM Filter Stop	1	VRH-184-500
25	PM Sealing Diaphragm	1	DIH-102-500	54	PM Inlet Screen	1	VRH-101-500
26	PM 1/4" NPT 3/8" Tube	1	BKF-64	55	PM Filter Pad	1	VRH-457-500
27	Tubing Connector (Vent) PM 1/4" NPT 1/2" Tube	1	BKF-84	56	Lead Gasket	1	GAH-LED-111
28	Tubing Connector (Vacuum)	1	SPH-100-000	PM	Part and Maintenance Kit	1	KTH-250-VRC
29	Spring Diaphragm Front Plate	1	VRH-269-500	*	Part of VRH-469-501 Assembly		



VACUUM REGULATOR

Date: 2022-12-02-v1
 BILL OF MATERIALS
 Dwg. No. VRH-250-CL2, BOM

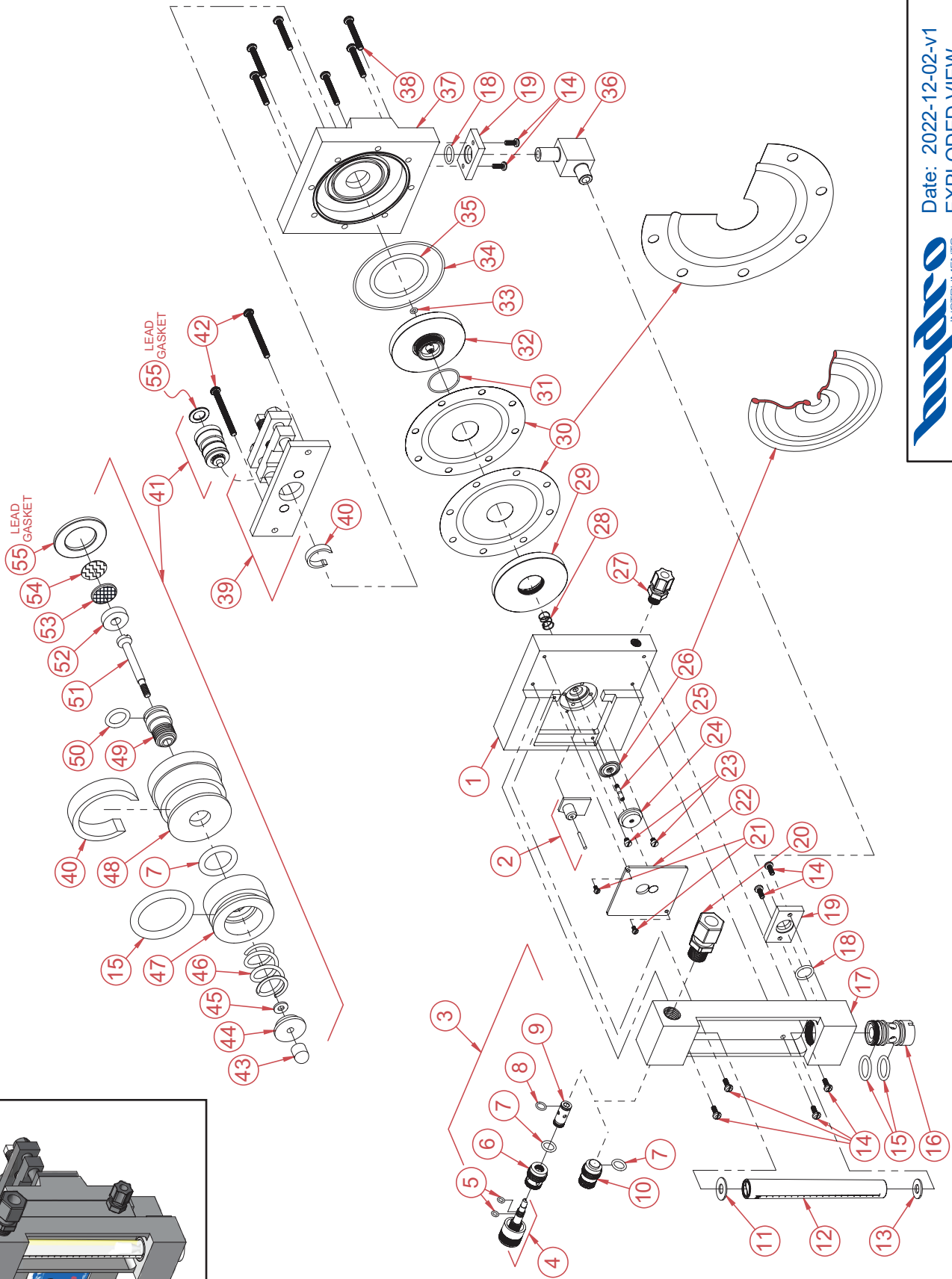
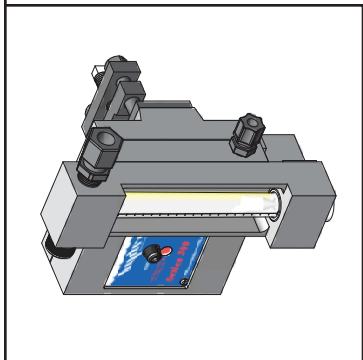

Item No.	Description	Quantity	Part No.	Item No.	Description	Quantity	Part No.
1	Front Body	1	VRH-256-500	30	PM Set of Two Diaphragms	1	DIH-106-500
2	Flag Assembly	1	VRH-445-500	31	PM O-Ring	1	OH-VIT-028
3	Rate Valve Assembly, 500 PPD	1	RVH-118-500	32	Diaphragm Back Plate	1	VRH-363-500
4	Rate Valve Stem & Knob	1	RVH-651-500	33	PM O-Ring	1	OH-VIT-009
5	PM O-Ring	2	OH-VIT-010	34	PM O-Ring	1	OH-VIT-156
6	Rate Valve Bonnet, 500 PPD	1	RVH-224-500	35	O-Ring	1	OH-VIT-331
7	PM O-Ring	2	OH-VIT-112	36	Flow Tube Assembly	1	VRH-321-500
8	PM O-Ring	1	OH-VIT-012	37	Back Body	1	VRH-234-500
9	Rate Valve Sleeve, 500 PPD	1	RVH-116-500	38	1/4-20 x 1 3/4" Body Screw	6	BTH-STA-124
10	Plug, 500 PPD	1	PLH-438-500	39	Yoke Assembly	1	VRH-346-500
11	PM Top Meter Gasket	1	GAH-VIT-116	40	* Retainer Clip	1	VRH-142-500
12	Meter Tube, 500 PPD	1	MTH-129-500	41	Inlet Assembly	1	VRH-469-501-1
13	PM Bottom Meter Gasket	1	GAH-VIT-115	42	1/4-20 x 2 3/4" Back Plate Screw	2	BTH-STA-125
14	10-24 x 1/2" Stainless Body Screw	8	BTH-STA-138	43	Vent Plug	1	VRH-111-500
15	PM O-Ring	3	OH-VIT-212	44	Spring Retainer	1	VRH-183-500
16	Meter Inlet, 500 PPD	1	MIH-232-500	45	Spring Holder	1	VRH-113-500
17	Meter Block	1	VRH-122-500	46	Inlet Spring	1	SPH-104-000
18	PM O-Ring	2	OH-VIT-114	47	PM Seal Plug	1	VRH-182-500
19	Clamp	2	VRH-235-500	48	Inlet Capsule	1	VRH-141-501
20	PM 1/2" NPT 5/8" Tubing Connector (Vacuum)	1	BKF-108	49	PM Valve Seat	1	VRH-110-500
21	6-32 x 5/16" Screw	2	BTH-STA-127	50	PM O-Ring	1	OH-VIT-011
22	Face Plate	1	VRH-441-500	51	Inlet Valve	1	VRH-112-500
23	10-24 x 3/16" PVC Screw	2	BTH-STA-128	52	PM Filter Stop	1	VRH-184-500
24	Seal Cover	1	VRH-137-500	53	PM Inlet Screen	1	VRH-101-500
25	Guide Pin	1	VRH-140-500	54	PM Filter Pad	1	VRH-457-500
26	PM Sealing Diaphragm	1	DIH-102-500	55	Lead Gasket	1	GAH-LED-111
27	PM 1/4" NPT 3/8" Tubing Connector (Vent)	1	BKF-64	PM	Part and Maintenance Kit	1	KTH-500-VRC
28	Spring	1	SPH-100-000	*	Part of VRH-469-501 Assembly		
29	Diaphragm Front Plate	1	VRH-269-500				



VACUUM REGULATOR
 Date: 2022-12-02-v1
 BILL OF MATERIALS
 Dwg. No. VRH-500-CL2, BOM

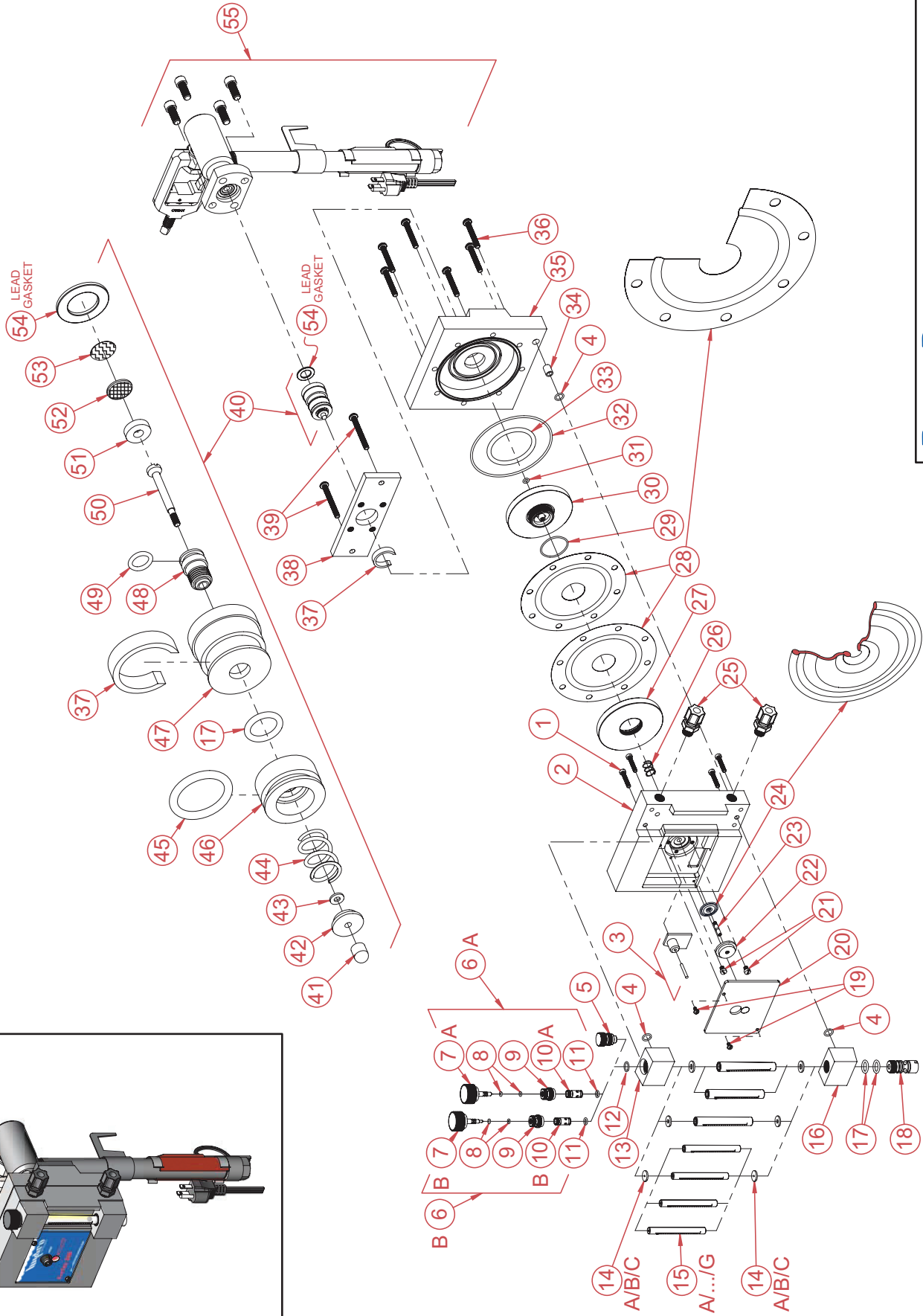
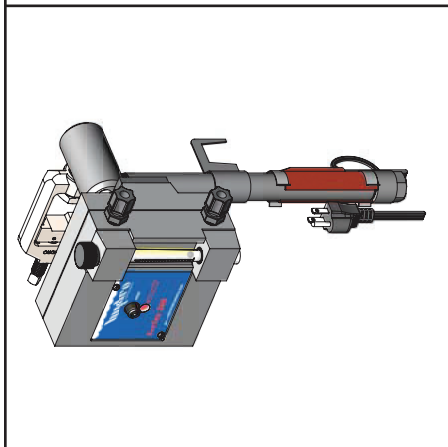

Item No.	Description	Quantity	Part No.	Item No.	Description	Quantity	Part No.
1	10-24 x 1" Meter Block Screw	4	BTH-STA-126	28	PM Set of Two Diaphragms	1	DIH-106-500
2	Front Body	1	VRH-107-250	29	PM O-Ring	1	OH-VIT-028
3	Flag Assembly	1	VRH-445-500	30	Diaphragm Back Plate	1	VRH-363-500
4	PM O-Ring	3	OH-VIT-012	31	PM O-Ring	1	OH-VIT-009
5	Bonnet Plug, 250 PPD	1	PLH-175-250	32	PM O-Ring	1	OH-VIT-156
6A	Rate Valve Assembly, 10 PPD	1	RVH-118-002V	33	O-Ring	1	OH-VIT-331
6B	Rate Valve Assembly, 100 PPD	1	RVH-118-003	34	Flow Tube	1	VRH-162-500
7A	Rate Valve Stem & Knob, 10 PPD	1	RVH-659-002V	35	Back Body	1	VRH-160-200
7B	Rate Valve Stem & Knob, 100 PPD	1	RVH-659-003	36	1/4-20 x 1 3/4" Body Screw	6	BTH-STA-124
8	PM O-Ring	2	OH-VIT-006	37	* Retainer Clip	1	VRH-142-500
9	Rate Valve Bonnet, 250 PPD	1	RVH-124-200	38	Ton Yoke Plate	1	VRH-739-501
10	Rate Valve Sleeve	1	RVH-125-003	39	1/4-20 x 2 3/4" Back Plate Screw	2	BTH-STA-125
11	PM O-Ring	1	OH-VIT-010	40	Inlet Valve Capsule Assembly	1	VRH-469-501-1
12	PM O-Ring	1	OH-VIT-110	41	Vent Plug	1	VRH-111-500
13	Top Meter Block	1	MBH-110-100	42	Spring Retainer	1	VRH-183-500
14A	PM Meter Gasket, 10 PPD	2	GAH-VIT-101	43	Spring Holder	1	VRH-113-500
14B	PM Meter Gasket, 25 PPD	2	GAH-VIT-102	44	Inlet Spring	1	SPH-104-000
14C	PM Meter Gasket, 100 PPD	2	GAH-VIT-103	45	PM O-Ring	1	OH-VIT-212
15A	Meter Tube, 0.6 PPD	1	MTH-108-006	46	PM Seal Plug	1	VRH-182-500
15B	Meter Tube, 1.5 PPD	1	MTH-108-0015	47	Inlet Capsule	1	VRH-141-501
15C	Meter Tube, 4 PPD	1	MTH-108-004	48	PM Valve Seat	1	VRH-110-500
15D	Meter Tube, 10 PPD	1	MTH-108-010	49	PM O-Ring	1	OH-VIT-011
15E	Meter Tube, 25 PPD	1	MTH-108-025	50	Inlet Valve	1	VRH-112-500
15F	Meter Tube, 50 PPD	1	MTH-108-050	51	PM Filter Stop	1	VRH-184-500
15G	Meter Tube, 100 PPD	1	MTH-108-100	52	PM Inlet Screen	1	VRH-101-500
16	Bottom Meter Block	1	MBH-109-100	53	PM Filter Pad	1	VRH-457-500
17	PM O-Ring	3	OH-VIT-112	54	PM Lead Gasket	1	GAH-LED-111
18	Meter Inlet, 250 PPD	1	MIH-140-200	55	Ton Inlet Assembly with Closed Yoke	1	VRH-738-501
19	6-32 x 5/16" Screw	2	BTH-STA-127				
20	Face Plate	1	VRH-441-250	PM	Part and Maintenance Kit	1	KTH-100-VRT
21	10-24 x 3/16" PVC Screw	2	BTH-STA-128	*	Part of VRH-469-501 Assembly		
22	Seal Cover	1	VRH-137-500				
23	Guide Pin	1	VRH-140-500				
24	PM Sealing Diaphragm	1	DIH-102-500				
25	PM 1/4" NPT x 3/8" Tubing Connector	2	BKF-64				
26	Spring	1	SPH-100-000				
27	Diaphragm Front Plate	1	VRH-269-500				



Date: 2022-12-02-v1
 BILL OF MATERIALS
 Dwg. No. VRH-10T-CL2, BOM

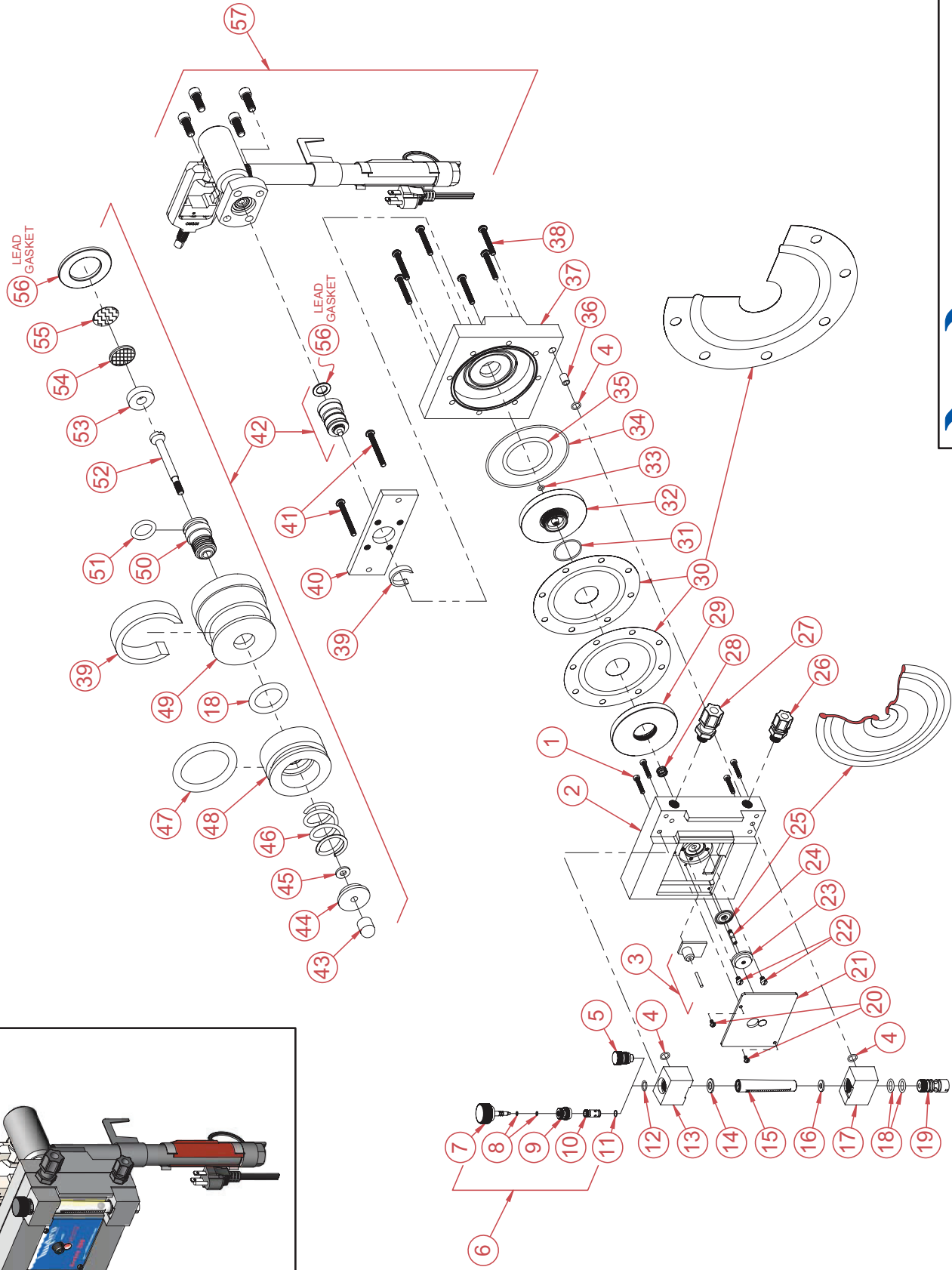
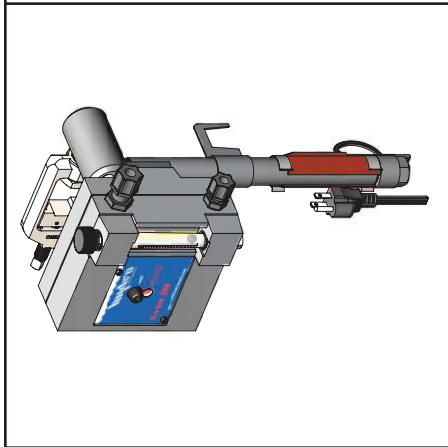

Item No.	Description	Quantity	Part No.	Item No.	Description	Quantity	Part No.
1	10-24 x 1" Meter Block Screw	4	BTH-STA-126	34	PM O-Ring	1	OH-VIT-156
2	Front Body	1	VRH-107-250	35	O-Ring	1	OH-VIT-331
3	Flag Assembly	1	VRH-445-500	36	Flow Tube	1	VRH-162-500
4	PM O-Ring	3	OH-VIT-012	37	Back Body	1	VRH-160-200
5	Bonnet Plug, 250 PPD	1	PLH-175-250	38	1/4-20 x 1 3/4" Body Screw	6	BTH-STA-124
6	Rate Valve Assembly	1	RVH-118-004	39	* Retainer Clip	1	VRH-142-500
7	Rate Valve Stem & Knob	1	RVH-659-004	40	Ton Yoke Plate	1	VRH-739-501
8	PM O-Ring	2	OH-VIT-006	41	1/4-20 x 2 3/4" Back Plate Screw	2	BTH-STA-125
9	Rate Valve Bonnet	1	RVH-124-200	42	Inlet Valve Capsule Assembly	1	VRH-469-501-1
10	Rate Valve Sleeve	1	RVH-125-003	43	Vent Plug	1	VRH-111-500
11	PM O-Ring	1	OH-VIT-010	44	Spring Retainer	1	VRH-183-500
12	PM O-Ring	1	OH-VIT-110	45	Spring Holder	1	VRH-113-500
13	Top Meter Block	1	MBH-117-250	46	Inlet Spring	1	SPH-104-000
14	PM Top Meter Gasket	1	GAH-VIT-104	47	PM O-Ring	1	OH-VIT-212
15	Meter Tube, 250 PPD	1	MTH-108-250	48	PM Seal Plug	1	VRH-182-500
16	Bottom Meter Gasket	1	GA-VIT-103	49	Inlet Capsule	1	VRH-141-501
17	Bottom Meter Block	1	MBH-116-250	50	PM Valve Seat	1	VRH-110-500
18	PM O-Ring	3	OH-VIT-112	51	PM O-Ring	1	OH-VIT-011
19	Meter Inlet	1	MIH-140-200	52	Inlet Valve	1	VRH-112-500
20	6-32 x 5/16" Screw	2	BTH-STA-127	53	PM Filter Stop	1	VRH-184-500
21	Face Plate	1	VRH-441-250	54	PM Inlet Screen	1	VRH-101-500
22	10-24 x 3/16" PVC Screw	2	BTH-STA-128	55	PM Filter Pad	1	VRH-457-500
23	Seal Cover	1	VRH-137-500	56	PM Lead Gasket	1	GAH-LED-111
24	Guide Pin	1	VRH-140-500	57	Ton Inlet Assembly with Closed Yoke	1	VRH-738-501
25	PM Sealing Diaphragm	1	DIH-102-500				
26	PM 1/4" NPT x 3/8" Tubing Connector (Vent)	1	BKF-64	PM	Part and Maintenance Kit	1	KTH-250-VRT
27	PM 1/4" NPT x 1/2" Tubing Connector (Vacuum)	1	BKF-84	*	Part of VRH-469-501 Assembly		
28	Spring	1	SPH-100-000				
29	Diaphragm Front Plate	1	VRH-269-500				
30	PM Set of Two Diaphragms	1	DIH-106-500				
31	PM O-Ring	1	OH-VIT-028				
32	Diaphragm Back Plate	1	VRH-363-500				
33	PM O-Ring	1	OH-VIT-009				



Date: 2022-12-02-v1
 BILL OF MATERIALS
 Dwg. No. VRH-25T-CL2, BOM

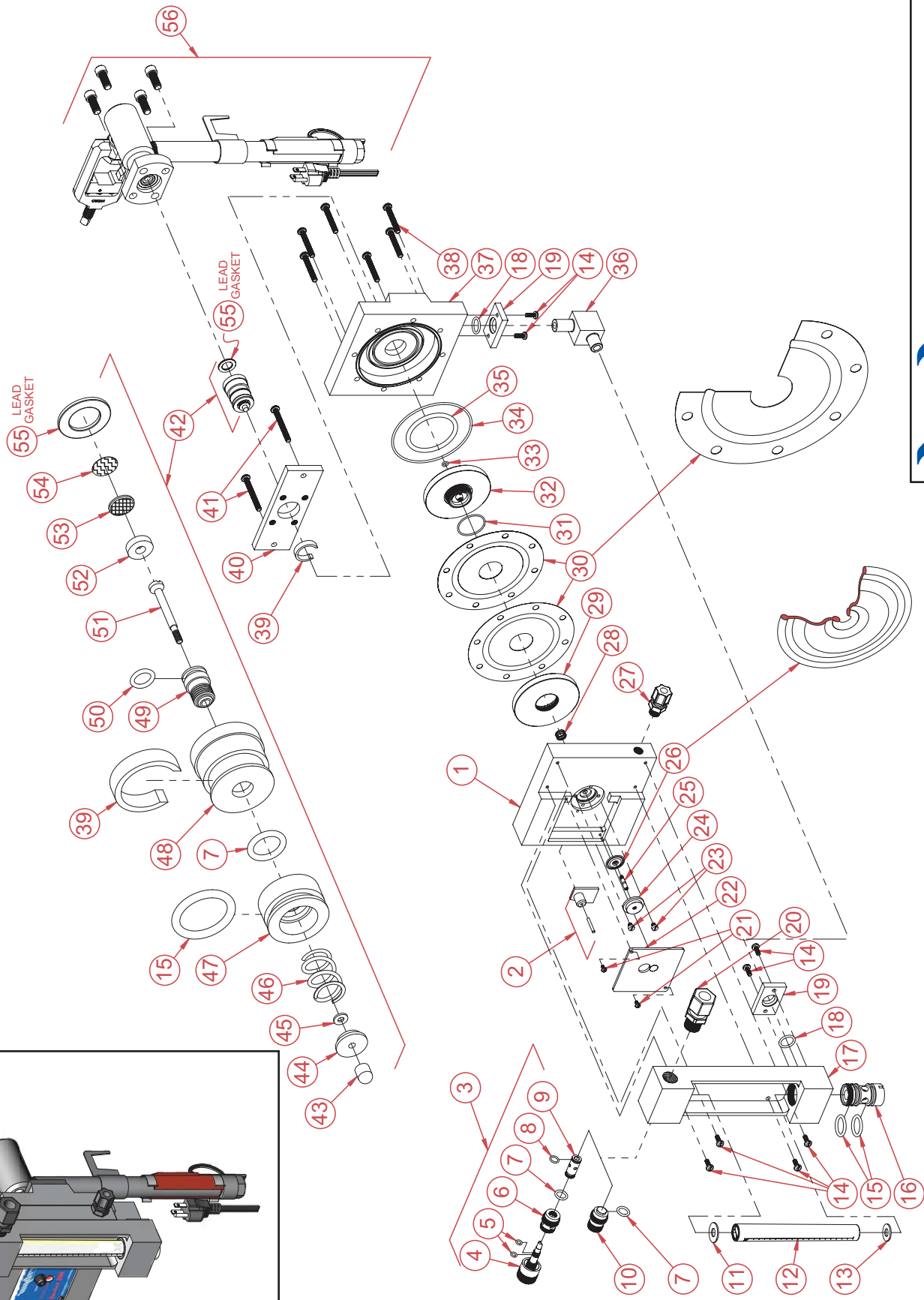
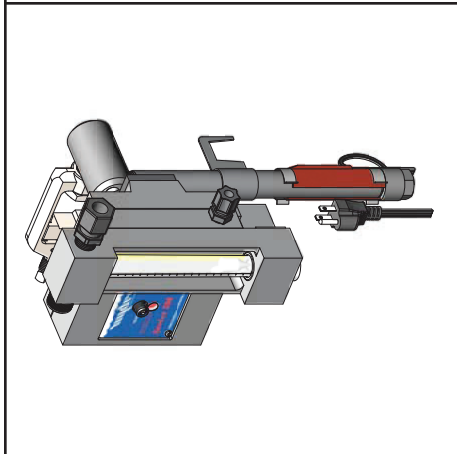



INSTRUMENTS™
 TON CONTAINER MOUNTED
 VACUUM REGULATOR
 Date: 2022-12-02-v1
 EXPLODED VIEW
 Dwg. No. VRH-50T-CL2, EXP

Item No.	Description	Quantity	Part No.	Item No.	Description	Quantity	Part No.
1	Front Body	1	VRH-256-500	32	Diaphragm Back Plate	1	VRH-363-500
2	Flag Assembly	1	VRH-445-500	33	PM O-Ring	1	OH-VIT-009
3	Rate Valve Assembly, 500 PPD	1	RVH-118-500	34	PM O-Ring	1	OH-VIT-156
4	Rate Valve Stem & Knob	1	RVH-651-500	35	O-Ring	1	OH-VIT-331
5	PM O-Ring	2	OH-VIT-010	36	Flow Tube Assembly	1	VRH-321-500
6	Rate Valve Bonnet, 500 PPD	1	RVH-224-500	37	Back Body	1	VRH-234-500
7	PM O-Ring	2	OH-VIT-112	38	1/4-20 x 1 3/4" Body Screw	6	BTH-STA-124
8	PM O-Ring	1	OH-VIT-012	39	* Retainer Clip	1	VRH-142-500
9	Rate Valve Sleeve, 500 PPD	1	RVH-116-500	40	Ton Yoke Plate	1	VRH-739-501
10	Plug, 500 PPD	1	PLH-438-500	41	1/4-20 x 2 3/4" Back Plate Screw	2	BTH-STA-125
11	PM Top Meter Gasket	1	GAH-VIT-116	42	Inlet Valve Capsule Assembly	1	VRH-469-501-1
12	Meter Tube, 500 PPD	1	MTH-129-500	43	Vent Plug	1	VRH-111-500
13	PM Bottom Meter Gasket	1	GAH-VIT-115	44	Spring Retainer	1	VRH-183-500
14	10-24 x 1/2" Stainless Meter Body Screw	8	BTH-STA-138	45	Spring Holder	1	VRH-113-500
15	PM O-Ring	3	OH-VIT-212	46	Inlet Spring	1	SPH-104-000
16	Meter Inlet, 500 PPD	1	MIH-232-500	47	PM Seal Plug	1	VRH-182-500
17	Meter Block	1	VRH-122-500	48	Inlet Capsule	1	VRH-141-501
18	PM O-Ring	2	OH-VIT-114	49	PM Valve Seat	1	VRH-110-500
19	Clamp	2	VRH-235-500	50	PM O-Ring	1	OH-VIT-011
20	PM 1/2" NPT x 5/8" Tube Tubing Connector (Vacuum)	1	BKF-108	51	Inlet Valve	1	VRH-112-500
21	6-32 x 5/16" Screw	2	BTH-STA-127	52	PM Filter Stop	1	VRH-184-500
22	Face Plate	1	VRH-441-500	53	PM Inlet Screen	1	VRH-101-500
23	10-24 x 3/16" PVC Screw	2	BTH-STA-128	54	PM Filter Pad	1	VRH-457-500
24	Seal Cover	1	VRH-137-500	55	PM Lead Gasket	1	GAH-LED-111
25	Guide Pin	1	VRH-140-500	56	Ton Inlet Assembly with Closed Yoke	1	VRH-738-501
26	PM Sealing Diaphragm	1	DIH-102-500	*	Part of VRH-469-501 Assembly		
27	PM 1/4" NPT x 3/8" Tube Tubing Connector (Vent)	1	BKF-64	PM	Part and Maintenance Kit	1	KTH-500-VRT
28	Spring	1	SPH-100-000				
29	Diaphragm Front Plate	1	VRH-269-500				
30	PM Set of Two Diaphragms	1	DIH-106-500				
31	PM O-Ring	1	OH-VIT-028				

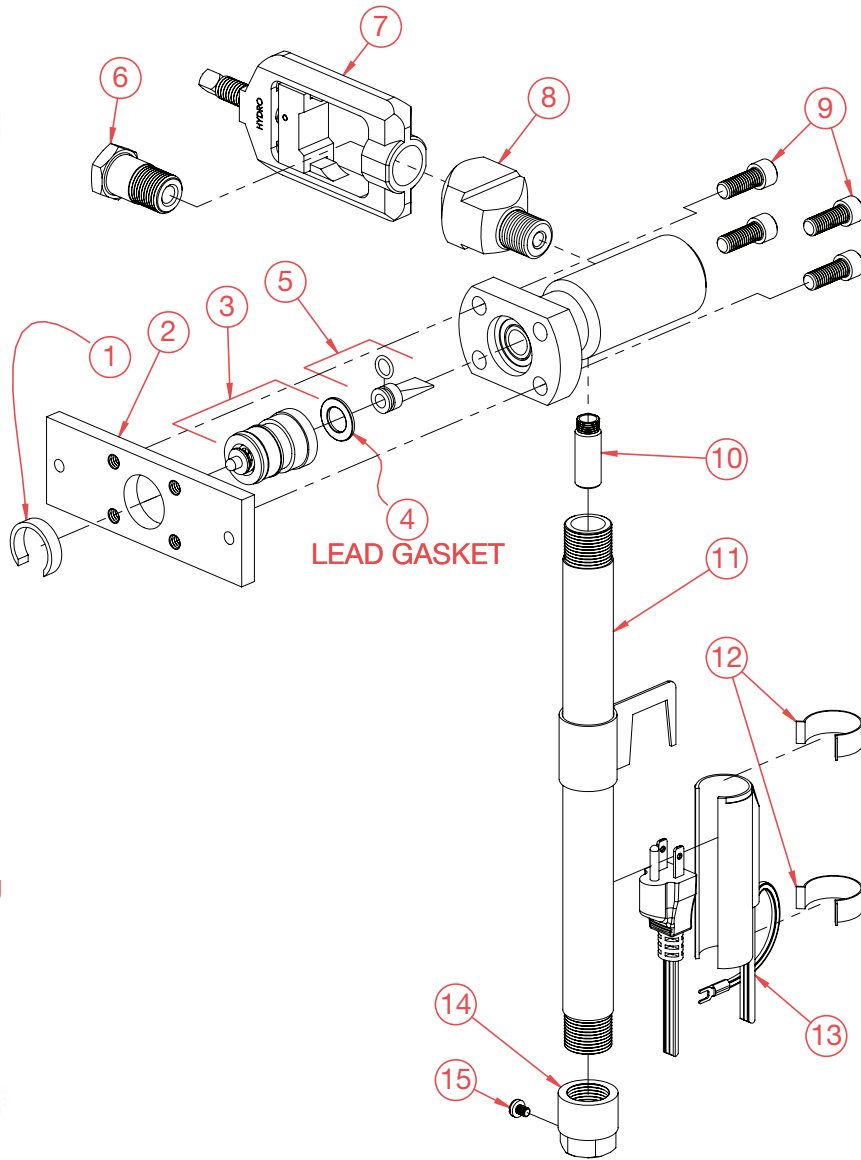
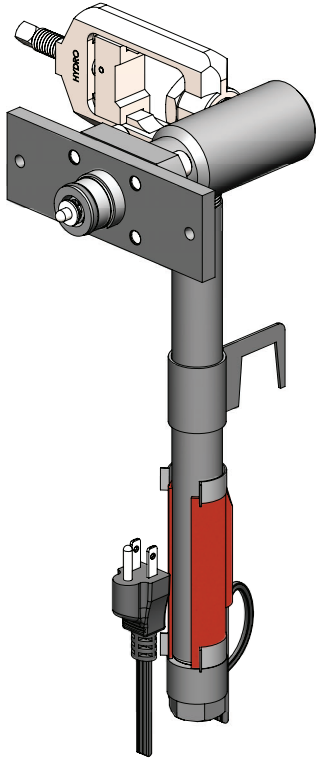

Date: 2022-12-02-v1
 BILL OF MATERIALS
 Dwg. No. VRH-50T-CL2, BOM

Ton Ironworks



**Actuator Mounting
Ton Ironworks**

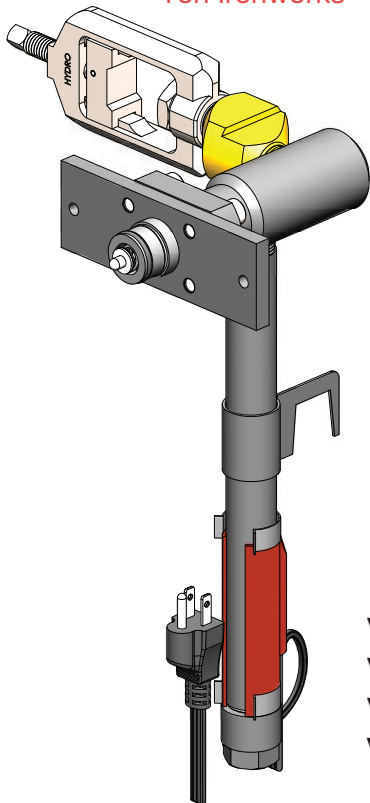

Part Number
VRH-738-501
VRH-999-500
VRH-738-501-AW
VRH-999-500-AW

With Seal Plug Assembly	Actuator Mounting
No (excludes items 1, 2, 3, 4, 9, and 13)	No (excludes item 8)
Yes	No (excludes item 8)
No (excludes items 1, 2, 3, 4, 9, and 13)	Yes (includes Item 8)
Yes	Yes (includes Item 8)



Date: 2023-05-17-v2
 EXPLODED VIEW
 Dwg. No. VRH-999-500, EXP

Item No.	Description	Quantity	Part No.
1	* Retainer Clip	1	VRH-142-500
2	Ton Yoke Plate	1	VRH-739-501
3	Inlet Valve Capsule Assembly	1	VRH-469-501-1
4	^{PM} Ton Ironwork Inner Lead Gasket	1	GAH-LED-111
5	^{PM} Filter Assembly (includes holder, screen, and o-ring)	1	VRH-126-500
6	Closed Yoke Adapter (Monel)	1	YAH-1300
7	Assembled Closed Yoke Assembly (includes yoke frame, half dog, slide bar, and pin)	1	YAH-705
8	** Eccentric Extender ½" MNPT x ½" FNPT (Bronze) (only included in actuator mounting configurations)	1	YAH-319
9	⅜-16 x 1" Socket Head Cap Screw	4	BTH-STA-139
10	✓ Drip Tube	1	DT-112
11	✓ Monel Drip Leg	1	DL-134
12	Heater Clamps	2	CLH-100-500
13	Drip Leg Heater (25W, 115VAC)	1	HTH-111-115
13	Drip Leg Heater (25W, 230VAC)	1	HTH-111-230
13	Drip Leg Heater, New Zealand (25W, 230VAC)	1	HTH-111-230-NZ
13	Drip Leg Heater (25W, 24VDC)	1	HTH-111-024
14	✓ Drip Leg Cap	1	DCM-15
15	Ground Screw (Stainless)	1	#10-32 x ¼"
✓	Not Sold Separately		
*	Part of VRH-469-501 Assembly (Item 3)		
**	Eccentric Extender is only used in actuator mounting configurations.		
^{PM}	Part & Maintenance kits for ton mounting vacuum regulators using the VRH-999-500 or VRH-738-501:		
	Series 300		
	VRH-10T-CL2		KTH-100-VRT
	VRH-25T-CL2		KTH-250-VRT
	VRH-50T-CL2		KTH-500-VRT
	Series 900		
	SVR-10T-CL2		KT9-100-VRT
	SVR-25T-CL2		KT9-250-VRT
	SVR-50T-CL2		KT9-500-VRT
	Part Number	With Seal Plug Assembly	Actuator Mounting
	VRH-738-501	No (excludes items 1, 2, 3, 4, 9, and 13)	No (excludes item 8)
	VRH-999-500	Yes	No (excludes item 8)
	VRH-738-501-AW	No (excludes items 1, 2, 3, 4, 9, and 13)	Yes (includes Item 8)
	VRH-999-500-AW	Yes	Yes (includes Item 8)
	 Date: 2023-05-17-v2 BILL OF MATERIALS Dwg. No. VRH-999-500, BOM TON IRONWORKS ASSEMBLY		

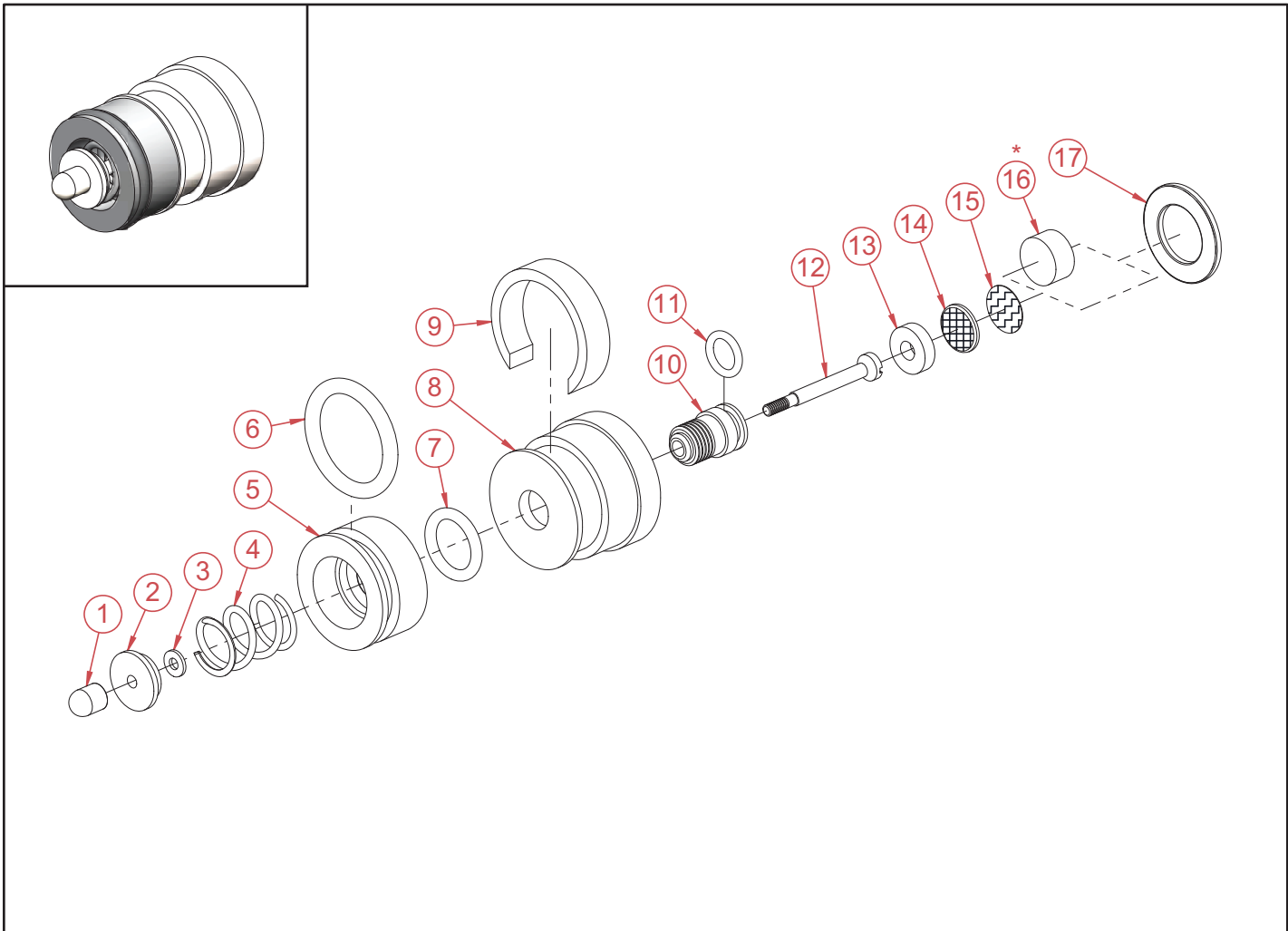

Item No.	Description	Quantity	Part No.
1	Vent Plug	1	VRH-111-500
2	Spring Retainer	1	VRH-183-500
3	Spring Holder	1	VRH-113-500
4	Inlet Spring	1	SPH-104-000
5	Seal Plug	1	VRH-182-500
6	O-Ring	1	OH-VIT-212
7	O-Ring	1	OH-VIT-112
8	Inlet Capsule	1	VRH-141-501
9	Retainer Clip	1	VRH-142-500
10	Valve Seat	1	VRH-110-500
11	O-Ring	1	OH-VIT-011
12	Inlet Valve	1	VRH-112-500
13	Filter Stop	1	VRH-184-500
14	Inlet Screen	1	VRH-101-500
15	Fiberglass Filter Pad	1	VRH-457-500
16	* Teflon Filter (100 PPD max)	1	VRH-456-100
17	Lead Gasket	1	GAH-LED-111

* Used in VRH-469-501: Non-ton mounting vacuum regulators, 100 PPD Cl₂ and smaller.



INLET VALVE CAPSULE ASSEMBLY

Date: 2020-11-11-v1
 EXPLODED VIEW AND BOM
 Dwg. No. VRH-469-501
 VRH-469-501-1

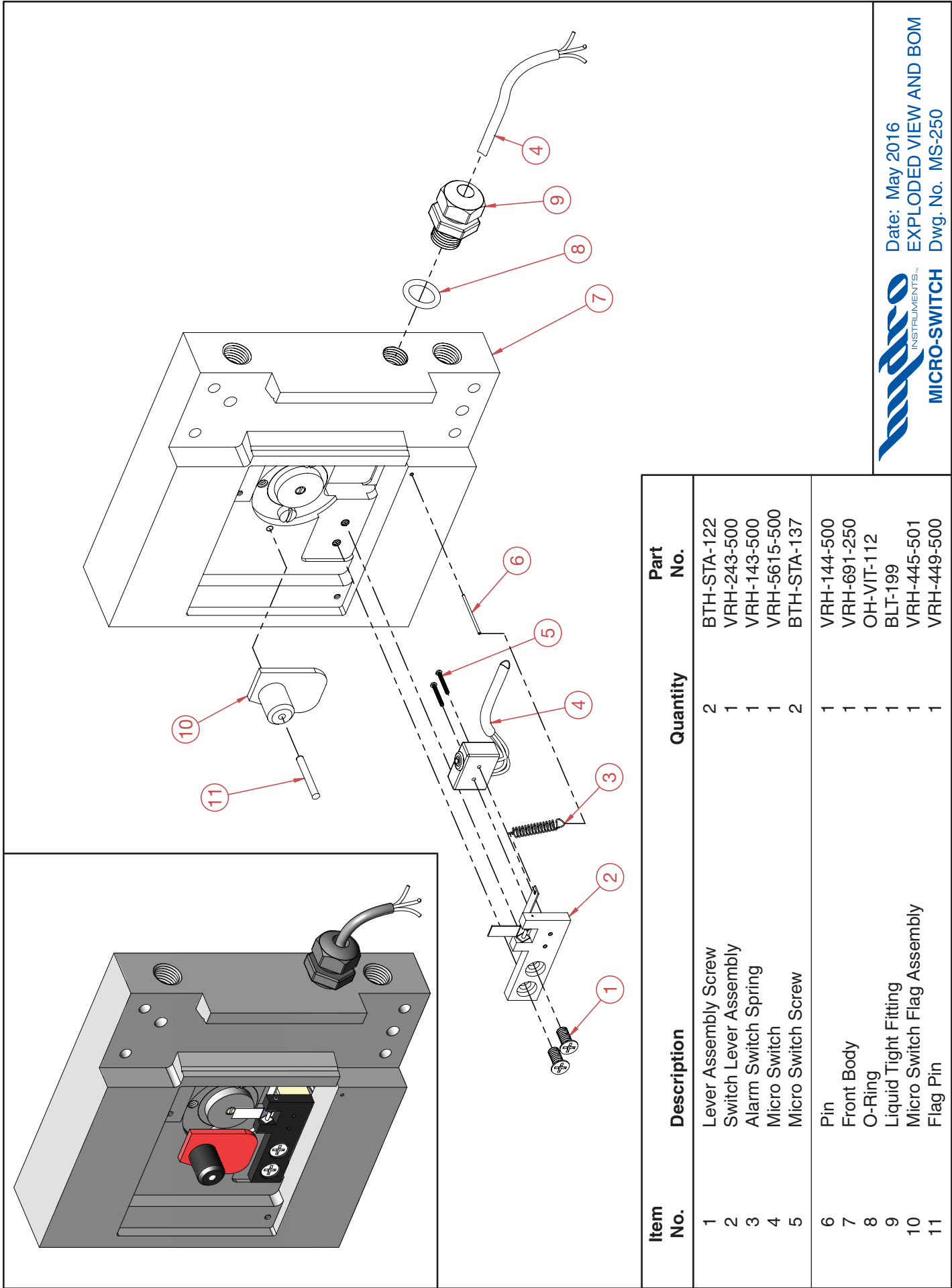

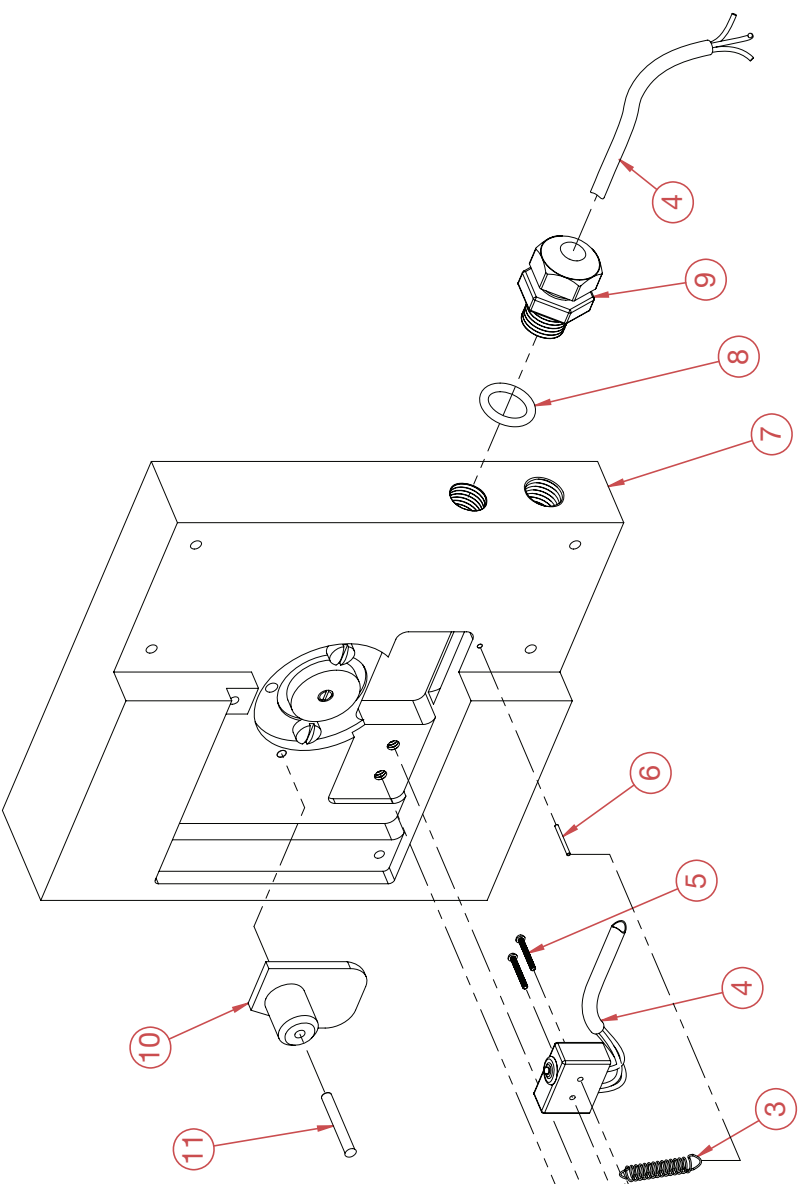
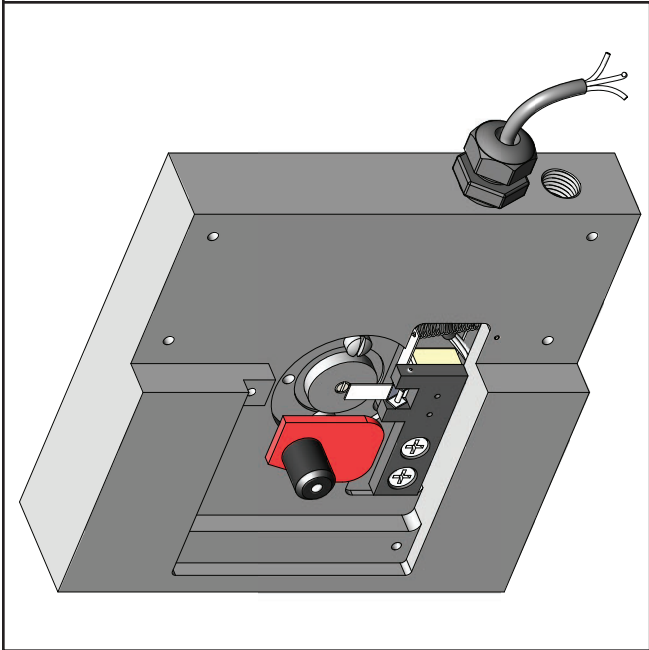

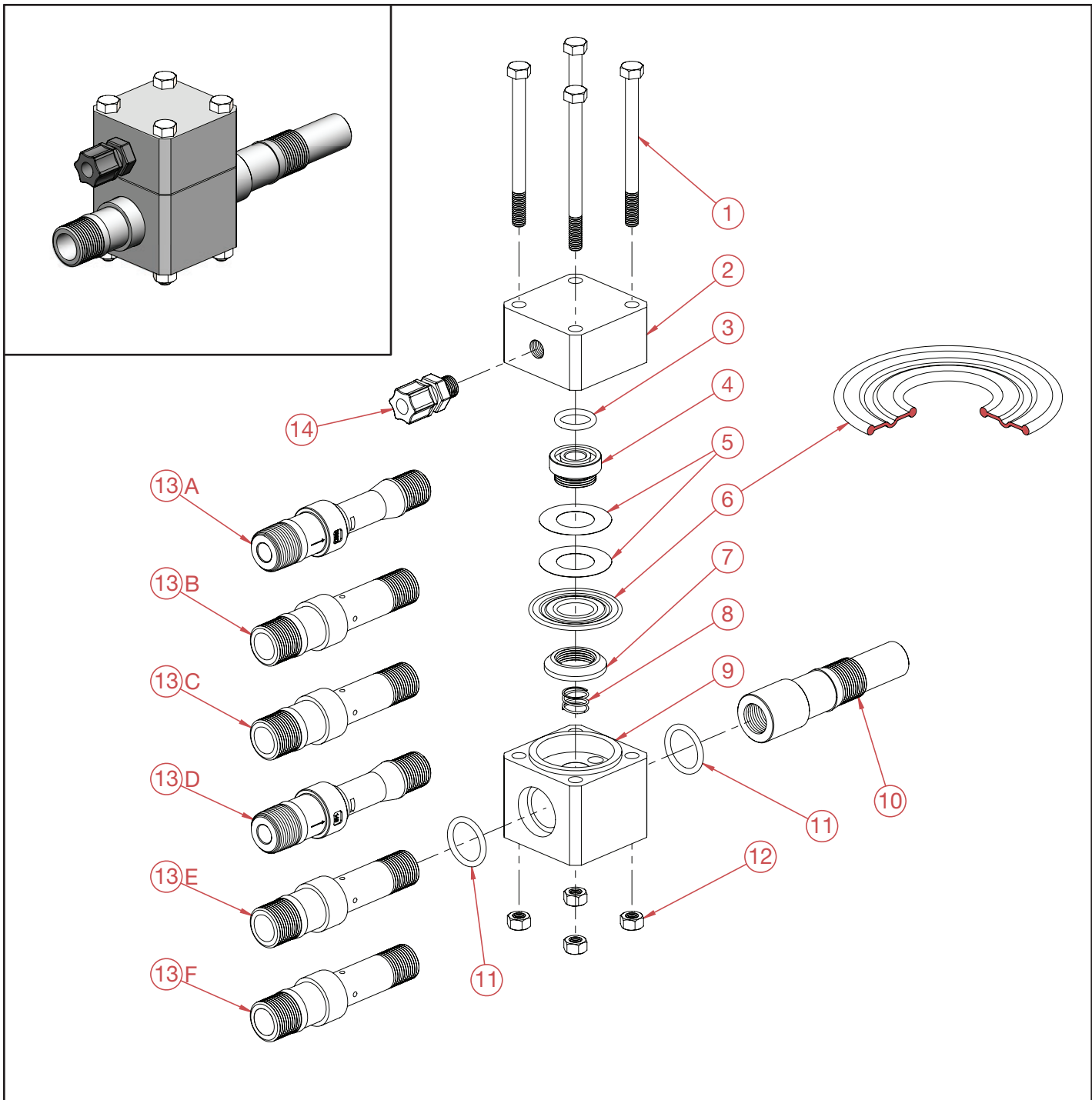

Item No.	Description	Quantity	Part No.
1	Lever Assembly Screw	2	BTH-STA-122
2	Switch Lever Assembly	1	VRH-243-500
3	Alarm Switch Spring	1	VRH-143-500
4	Micro Switch	1	VRH-5615-500
5	Micro Switch Screw	2	BTH-STA-137
6	Pin	1	VRH-144-500
7	Front Body	1	VRH-733-500
8	O-Ring	1	OH-VIT-112
9	Liquid Tight Fitting	1	BLT-199
10	Micro Switch Flag Assembly	1	VRH-445-501
11	Flag Pin	1	VRH-449-500

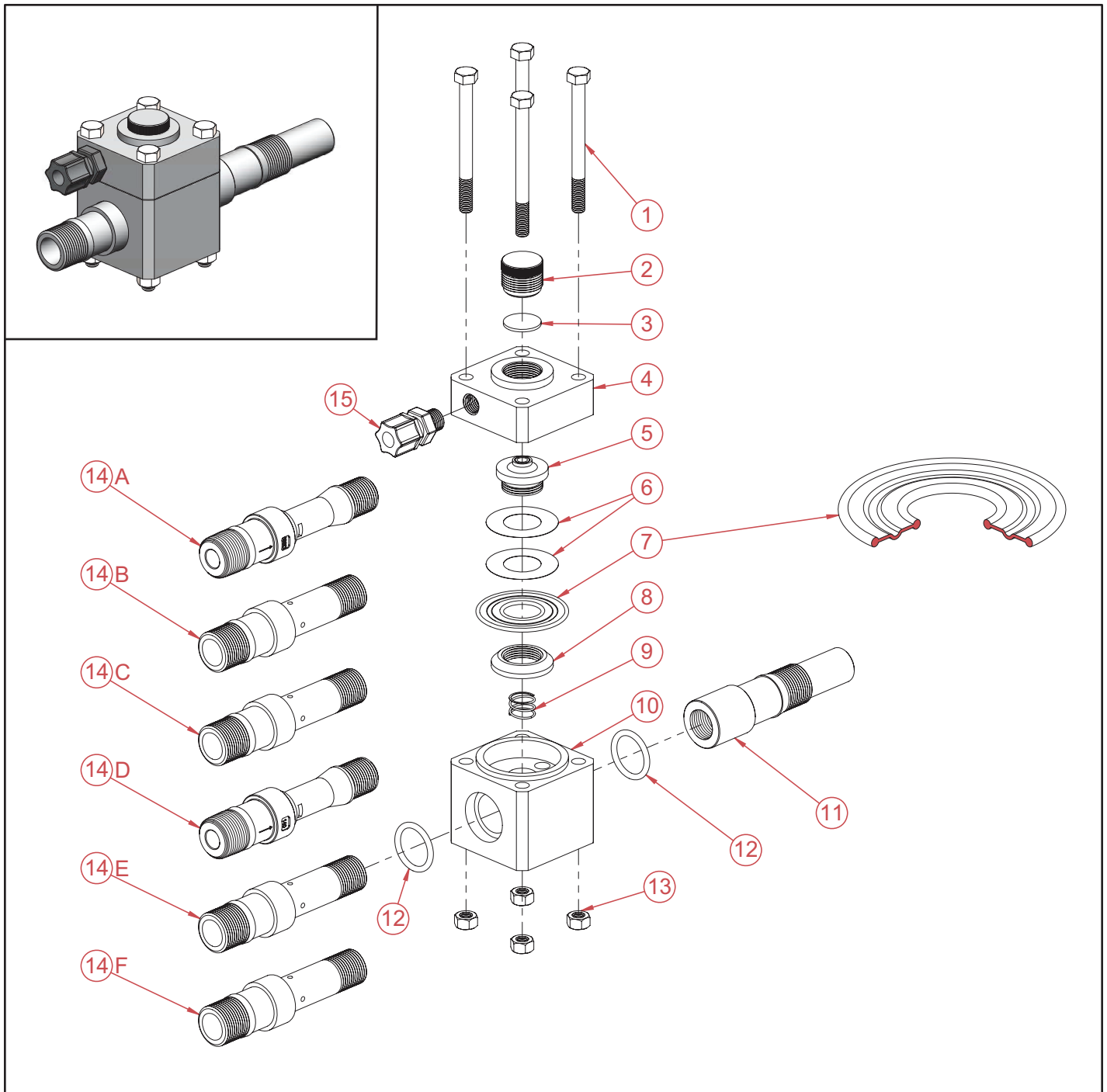

Item No.	Description	Quantity	Part No.	Item No.	Description	Quantity	Part No.
1	5/16-18 x 4" Bolt	4	BTH-STA-136	13 A	* Nozzle (50 PPD max.)	1	UN-102-099D
2	Top Body	1	EJH-237-250	13 B	* Nozzle (25 PPD max.)	1	CNH-016-106
3	^{PM} O-Ring	1	OH-CEM-210	13 C	* Nozzle (50 PPD max.)	1	CNH-013-128
4	^{PM} Diaphragm Bolt	1	EJH-236-500	13 D	* Nozzle (100 PPD max.)	1	UN-102-140
5	^{PM} Set of Two Support Diaphragms	1	DIH-105-500	13 E	* Nozzle (100 PPD max.)	1	CNH-015-156
6	^{PM} Diaphragm	1	DIH-104-500	13 F	* Nozzle (100 PPD max.)	1	CNH-012-191
7	^{PM} Diaphragm Nut	1	EJH-146-500	14	^{PM} 3/8" Tubing Connector	1	BKF-64
8	Spring	1	SPH-106-000	^{PM}	Part and Maintenance Kit	1	KTH-100-EJO
9	Bottom Body	1	EJH-153-500	*	Refer to nozzle sizing charts for correct sizing.		
10	Multi Purpose Diffuser	1	EJH-982-100	 Date: April 2017 EJECTOR (O-RING) Dwg. No. EJO-100-CL2			
11	^{PM} O-Ring	2	OH-VIT-214				
12	5/16-18 Nut	4	NTH-STA-104				



Item No.	Description	Quantity	Part No.	Item No.	Description	Quantity	Part No.
1	5/16-18 x 3 1/2" Bolt	4	BTH-STA-135	14 A	* Nozzle (50 PPD max.)	1	UN-102-099D
2	Seat Plug	1	EJH-311-200	14 B	* Nozzle (25 PPD max.)	1	CNH-016-106
3	PM Valve Seat	1	GAH-VIT-122	14 C	* Nozzle (50 PPD max.)	1	CNH-013-128
4	Top Body	1	EJH-208-200	14 D	* Nozzle (100 PPD max.)	1	UN-102-140
5	PM Diaphragm Bolt	1	EJH-206-200	14 E	* Nozzle (100 PPD max.)	1	CNH-015-156
6	PM Set of Two Support Diaphragms	1	DIH-105-500	14 F	* Nozzle (100 PPD max.)	1	CNH-012-191
7	PM Diaphragm	1	DIH-104-500	15	PM 3/8" Tubing Connector	1	BKF-64
8	PM Diaphragm Nut	1	EJH-146-500	PM	Part and Maintenance Kit	1	KTH-100-EJS
9	Spring	1	SPH-106-000	*	Refer to nozzle sizing charts for correct sizing.		
10	Bottom Body	1	EJH-153-500	 Date: 2023-01-17-v1 EXPLODED VIEW AND BOM Dwg. No. EJH-100-CL2			
11	Multi Purpose Diffuser	1	EJH-982-100				
12	PM O-Ring	2	OH-VIT-214				
13	5/16-18 Nut	4	NTH-STA-104				

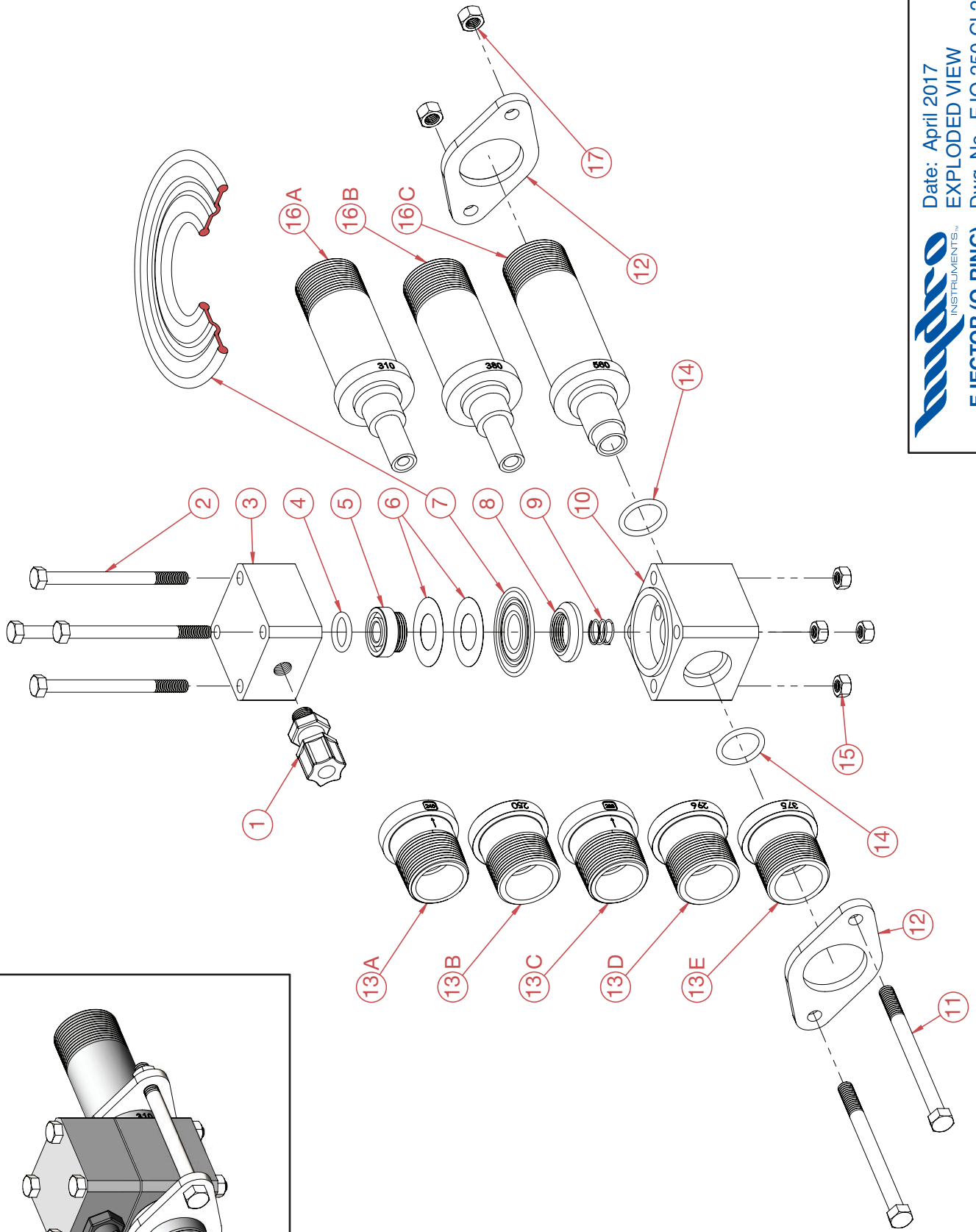
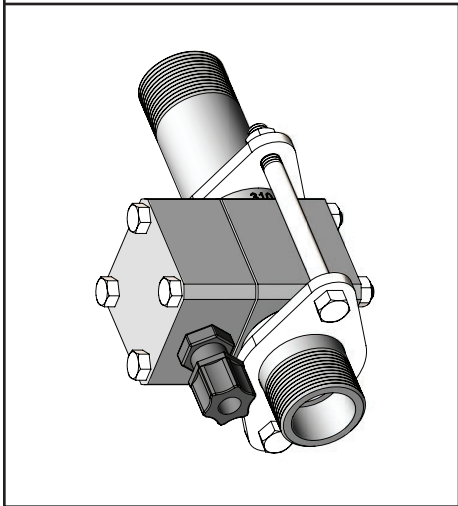

Item No.	Description	Quantity	Part No.
1	PM 1/4" NPT 1/2" Tube Tubing Connector	1	BKF-84
2	5/16-18 x 4" Bolt	4	BTH-STA-136
3	Top Body	1	EJH-237-250
4	PM O-Ring	1	OH-CEM-210
5	PM Diaphragm Bolt	1	EJH-236-500
6	PM Set of Two Support Diaphragms	1	DIH-105-500
7	PM Diaphragm	1	DIH-104-500
8	PM Diaphragm Nut	1	EJH-146-500
9	Spring	1	SPH-106-000
10	Bottom Body	1	EJH-153-500
11	3/8-14 x 4 1/2" Bolt	2	BTH-STA-145
12	Flange	2	EJH-136-500
13A	* Nozzle – .240	1	ENX-240
13B	* Nozzle – .250	1	TNH-187-250
13C	* Nozzle – .290	1	ENX-290
13D	* Nozzle – .300	1	TNH-187-300
13E	* Nozzle – .375	1	TNH-187-375
14	PM O-Ring	2	OH-VIT-214
15	5/16-18 Nut	4	NTH-STA-104
16A	* Throat – .310	1	TTH-189-310
16B	* Throat – .380	1	TTH-189-386
16C	* Throat – .560	1	TTH-189-562
17	3/8 Nut	2	NTH-STA-106
PM	Part & Maintenance Kit	1	KTH-250-EJO
*	Refer to nozzle sizing charts for correct sizing.		



Date: April 2017
 BILL OF MATERIALS
 Dwg. No. EJO-250-CL2, BOM

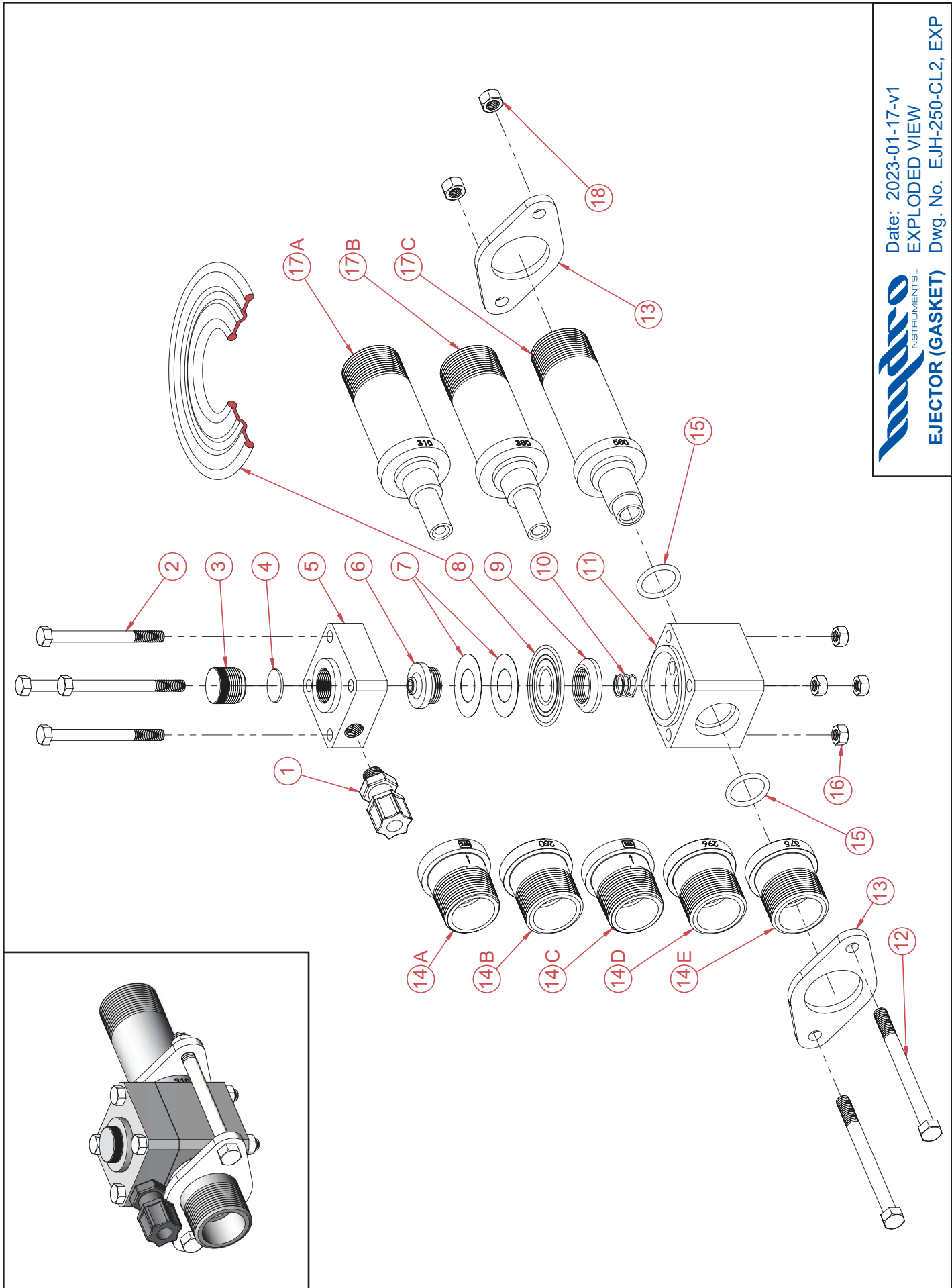



Mudpro
 INSTRUMENTS
 Date: 2023-01-17-v1
 EXPLODED VIEW
 EJECTOR (GASKET) Dwg. No. EJH-250-CL2, EXP

Item No.	Description	Quantity	Part No.
1	PM 1/4" NPT 1/2" Tube Tubing Connector	1	BKF-84
2	5/16-18 x 4" Bolt	4	BTH-STA-135
3	Seat Plug	1	EJH-311-200
4	PM Valve Seat	1	GAH-VIT-122
5	Top Body	1	EJH-208-200
6	PM Diaphragm Bolt	1	EJH-206-200
7	PM Set of Two Support Diaphragms	1	DIH-105-500
8	PM Diaphragm	1	DIH-104-500
9	PM Diaphragm Nut	1	EJH-146-500
10	Spring	1	SPH-106-000
11	Bottom Body	1	EJH-153-500
12	3/8-14 x 4 1/2" Bolt	2	BTH-STA-145
13	Flange	2	EJH-136-500
14A	* Nozzle – .240	1	ENX-240
14B	* Nozzle – .250	1	TNH-187-250
14C	* Nozzle – .290	1	ENX-290
14D	* Nozzle – .300	1	TNH-187-300
14E	* Nozzle – .375	1	TNH-187-375
15	PM O-Ring	2	OH-VIT-214
16	5/16-18 Nut	4	NTH-STA-104
17A	* Throat – .310	1	TTH-189-310
17B	* Throat – .380	1	TTH-189-386
17C	* Throat – .560	1	TTH-189-562
18	3/8 Nut	2	NTH-STA-106
PM	Part & Maintenance Kit	1	KTH-250-EJS
*	Refer to nozzle sizing charts for correct sizing.		

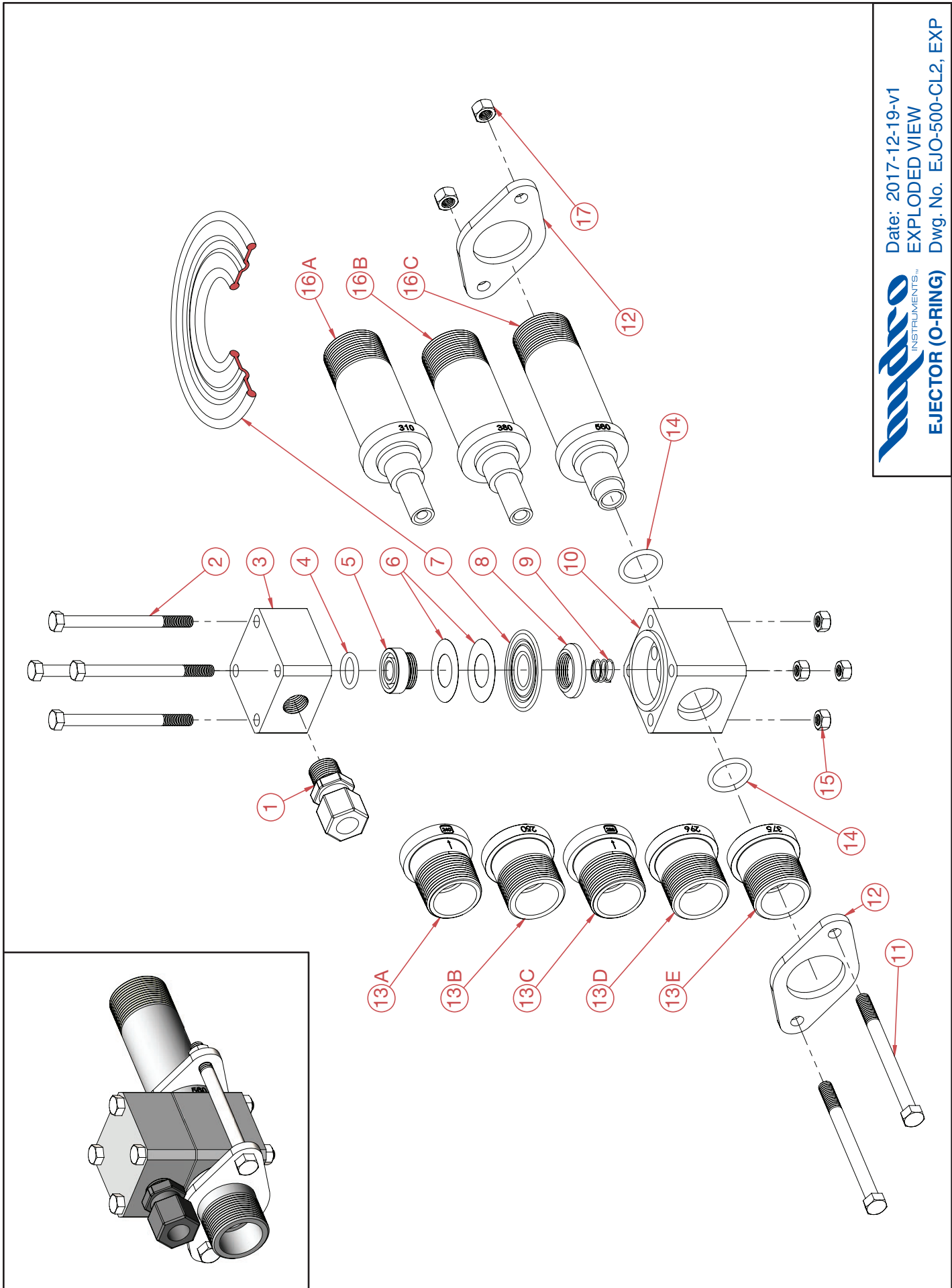

Date: 2023-01-17-v1
 BILL OF MATERIALS
 Dwg. No. EJH-250-CL2, BOM



Item No.	Description	Quantity	Part No.
1	PM 1/2" NPT 5/8" Tube Tubing Connector	1	BKF-108
2	5/16-18 x 4" Bolt	4	BTH-STA-136
3	Top Body	1	EJH-237-500
4	PM O-Ring	1	OH-CEM-210
5	PM Diaphragm Bolt	1	EJH-236-500
6	PM Set of Two Support Diaphragms	1	DIH-105-500
7	PM Diaphragm	1	DIH-104-500
8	PM Diaphragm Nut	1	EJH-146-500
9	Spring	1	SPH-106-000
10	Bottom Body	1	EJH-153-500
11	3/8-14 x 4 1/2" Bolt	2	BTH-STA-145
12	Flange	2	EJH-136-500
13A	* Nozzle – .240	1	ENX-240
13B	* Nozzle – .250	1	TNH-187-250
13C	* Nozzle – .290	1	ENX-290
13D	* Nozzle – .300	1	TNH-187-300
13E	* Nozzle – .375	1	TNH-187-375
14	PM O-Ring	2	OH-VIT-214
15	5/16-18 Nut	4	NTH-STA-104
16A	* Throat – .310	1	TTH-189-310
16B	* Throat – .380	1	TTH-189-386
16C	* Throat – .560	1	TTH-189-562
17	3/8 Nut	2	NTH-STA-106
PM	Part & Maintenance Kit	1	KTH-500-EJO
*	Refer to nozzle sizing charts for correct sizing.		



Date: 2017-12-19-v1
 BILL OF MATERIALS
 Dwg. No. EJO-500-CL2, BOM

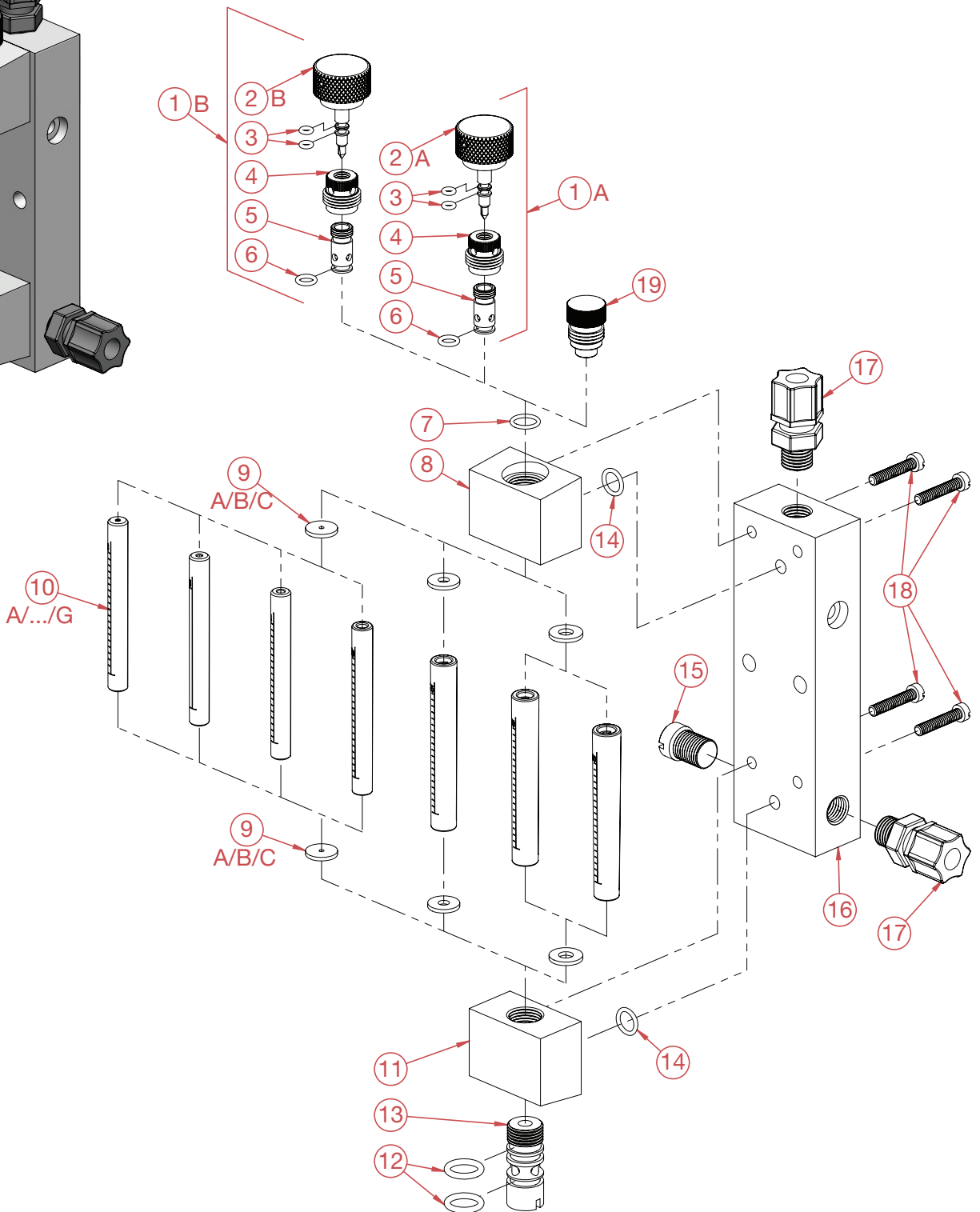
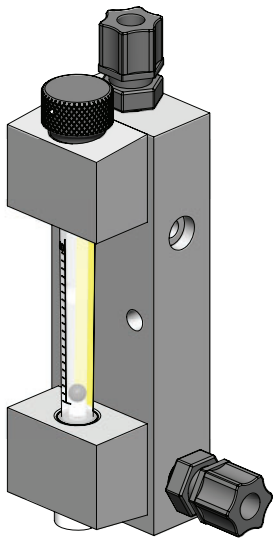

Date: 2018-11-01-v1
EXPLODED VIEW
Dwg. No. MPH-100-CL2, EXP

REMOTE METER (100 PPD)

Item No.	Description	Quantity	Part No.
1 A	Rate Valve Assembly, 10 PPD max.	1	RVH-118-002V
1 B	Rate Valve Assembly, 100 PPD max.	1	RVH-118-003
2 A	Rate Valve Plug, 10 PPD max.	1	RVH-659-002V
2 B	Rate Valve Plug, 100 PPD max.	1	RVH-659-003
3	^{PM} O-Ring	2	OH-VIT-006
4	Rate Valve Bonnet, 250 PPD max.	1	RVH-124-200
5	Rate Valve Sleeve	1	RVH-125-003
6	^{PM} O-Ring	1	OH-VIT-010
7	^{PM} O-Ring	1	OH-VIT-110
8	Top Meter Block	1	MBH-110-100
9 A	^{PM} Meter Gasket, 10 PPD max.	2	GAH-VIT-101
9 B	^{PM} Meter Gasket, 25 PPD max.	2	GAH-VIT-102
9 C	^{PM} Meter Gasket, 100 PPD max.	2	GAH-VIT-103
10 A	Meter Tube, 0.6 PPD max.	1	MTH-108-006
10 B	Meter Tube, 1.5 PPD max.	1	MTH-108-0015
10 C	Meter Tube, 4 PPD max.	1	MTH-108-004
10 D	Meter Tube, 10 PPD max.	1	MTH-108-010
10 E	Meter Tube, 25 PPD max.	1	MTH-108-025
10 F	Meter Tube, 50 PPD max.	1	MTH-108-050
10 G	Meter Tube, 100 PPD max.	1	MTH-108-100
11	Bottom Meter Block	1	MBH-109-100
12	^{PM} O-Ring	2	OH-VIT-112
13	Meter Inlet, 250 PPD	1	MIH-140-200
14	^{PM} O-Ring	2	OH-VIT-012
15	¼" NPT Plug	1	PLH-108-250
16	Meter Panel Body	1	MPH-248-250
17	^{PM} ⅜" Tubing Connector	2	BKF-64
18	10-24 x 1" Bolt	4	BTH-STA-126
19	Bonnet Plug, 250 PPD	1	PLH-175-250
^{PM}	Part & Maintenance Kit	1	KTH-100-RMP

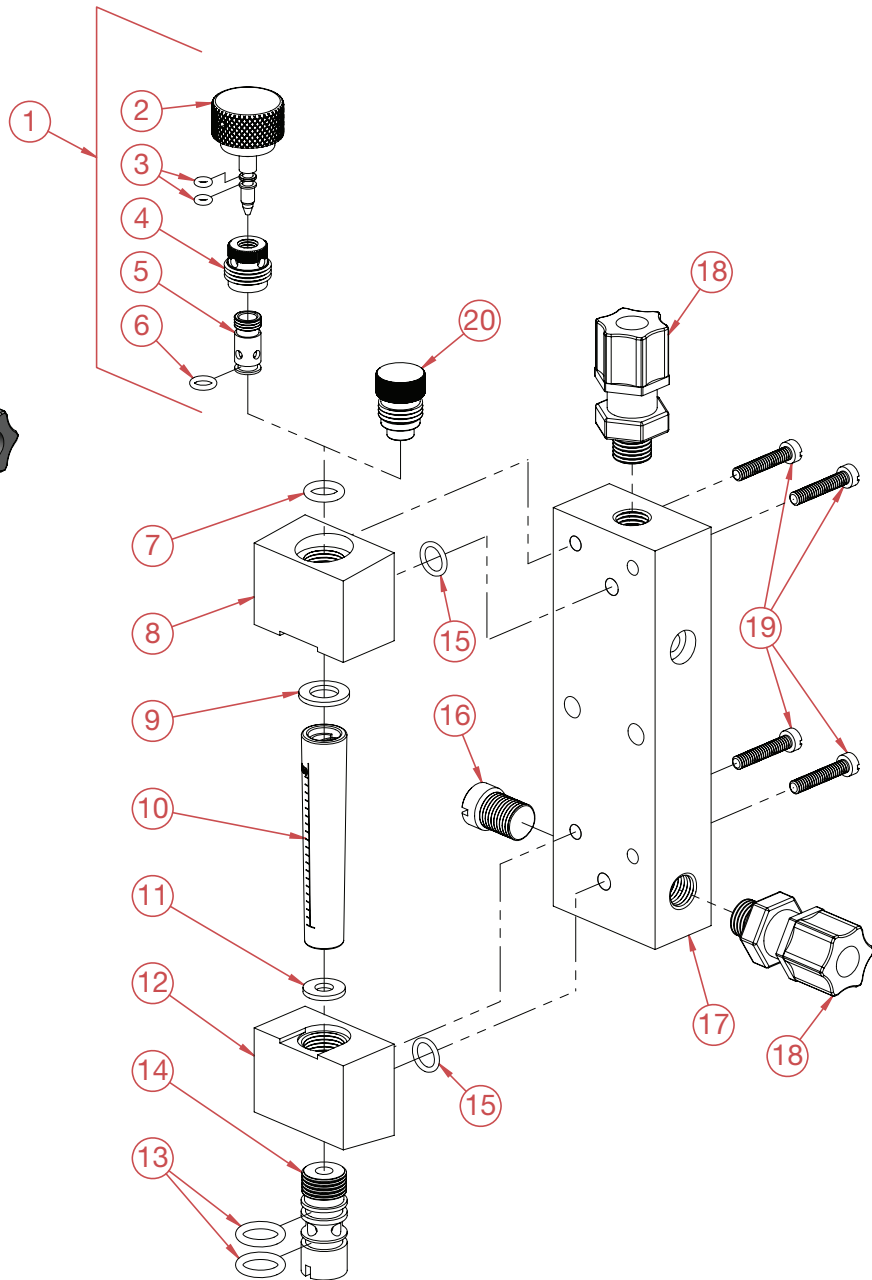
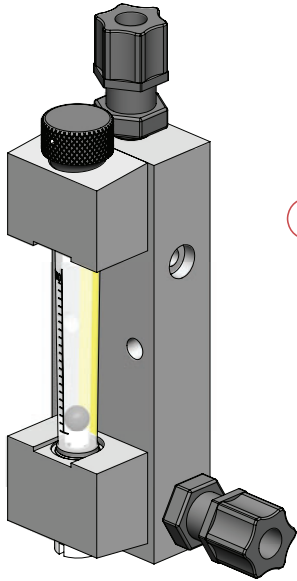

Item No.	Description	Quantity	Part No.
1	Rate Valve Assembly, 250 PPD max.	1	RVH-118-004
2	Rate Valve Plug, 250 PPD max.	1	RVH-659-004
3	^{PM} O-Ring	2	OH-VIT-006
4	Rate Valve Bonnet, 250 PPD max.	1	RVH-124-200
5	Rate Valve Sleeve, 250 PPD max.	1	RVH-125-003
6	^{PM} O-Ring	1	OH-VIT-010
7	^{PM} O-Ring	1	OH-VIT-110
8	Top Meter Block	1	MBH-117-250
9	^{PM} Top Meter Gasket, 250 PPD max.	1	GAH-VIT-104
10	Meter Tube, 250 PPD max.	1	MTH-108-250
11	^{PM} Bottom Meter Gasket, 250 PPD max.	1	GAH-VIT-103
12	Bottom Meter Block	1	MBH-116-250
13	^{PM} O-Ring	2	OH-VIT-112
14	Meter Inlet, 250 PPD	1	MIH-140-200
15	^{PM} O-Ring	2	OH-VIT-012
16	¼" NPT Plug	1	PLH-108-250
17	Meter Panel Body	1	MPH-248-250
18	^{PM} ½" Tubing Connector	2	BKF-84
19	10-24 x 1" Bolt	4	BTH-STA-126
20	Bonnet Plug, 250 PPD	1	PLH-175-250
^{PM}	Part & Maintenance Kit	1	KTH-250-RMP

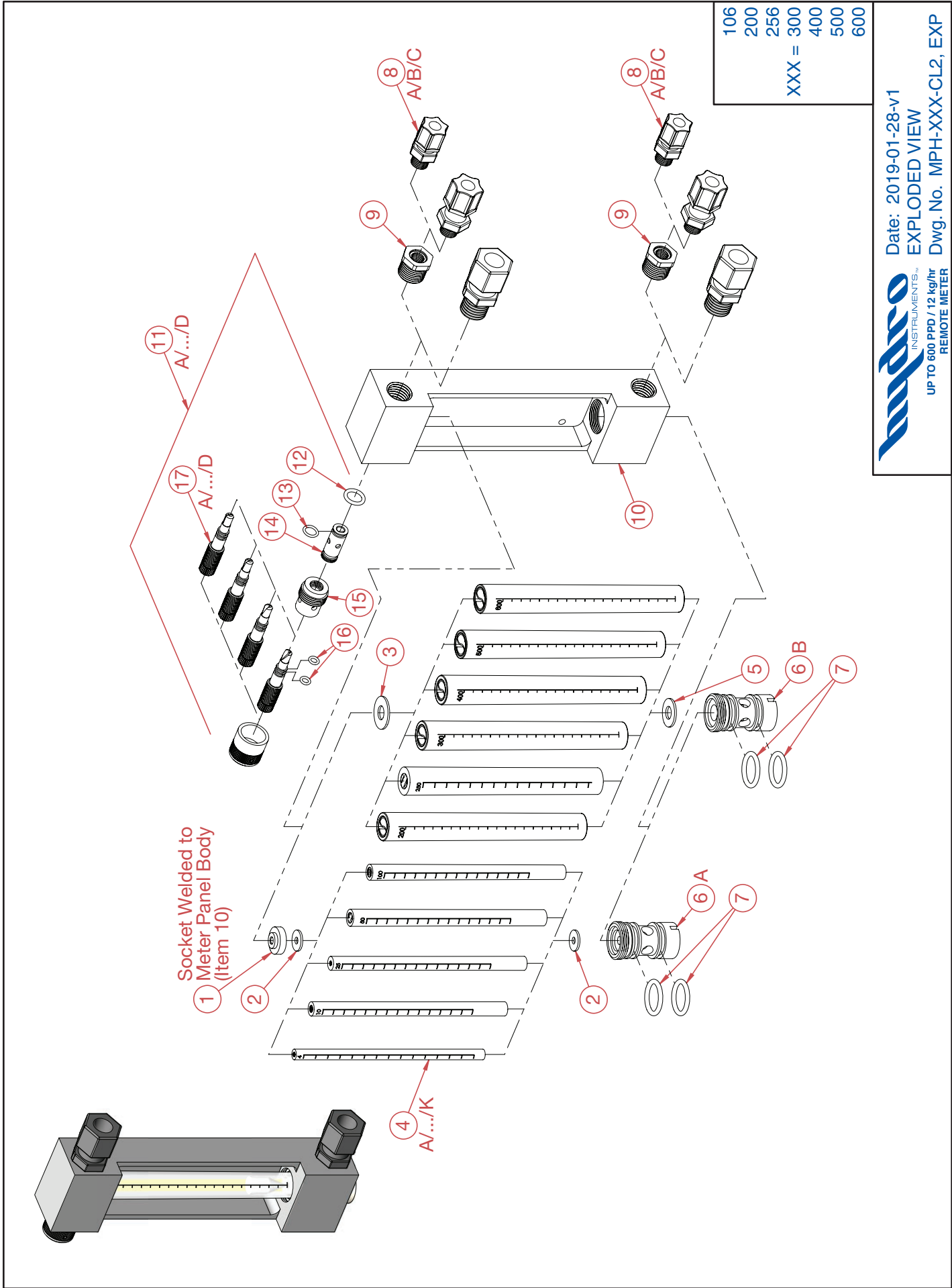

Item No.	Description	Quantity	Part No.	Item No.	Description	Quantity	Part No.
1	Meter Tube Adapter, 10-100 PPD (Socket Welded to Meter Panel Body, Item 10)	1	MPH-830-101	11A	Rate Valve Assembly, 4 & 10 PPD	1	RVH-118-010
2	^{PM} Meter Gasket, Top and Bottom	2	MG-200B	11B	Rate Valve Assembly, 100 PPD	1	RVH-118-100
3	^{PM} Top Meter Gasket, 200-600 PPD	1	GAH-VIT-116	11C	Rate Valve Assembly, 250 PPD	1	RVH-118-250
4A	Meter Tube, 4 PPD	1	MT-678-004	11D	Rate Valve Assembly, 500 PPD	1	RVH-118-500
4B	Meter Tube, 10 PPD	1	MTH-129-010	12	^{PM} O-Ring	1	OH-VIT-112
4C	Meter Tube, 25 PPD	1	MTH-129-025	13	^{PM} O-Ring	1	OH-VIT-012
4D	Meter Tube, 50 PPD	1	MTH-129-050	14	Rate Valve Sleeve	1	RVH-116-500
4E	Meter Tube, 100 PPD	1	MTH-129-100	15	Rate Valve Bonnet	1	RVH-224-500
4F	Meter Tube, 200 PPD	1	MTH-129-200	16	^{PM} O-Ring	2	OH-VIT-010
4G	Meter Tube, 250 PPD	1	MTH-129-250	17A	Rate Valve Stem & Knob, 4-10 PPD	1	RVH-651-010
4H	Meter Tube, 300 PPD	1	MTH-129-300	17B	Rate Valve Stem & Knob, 25-100 PPD	1	RVH-651-100
4I	Meter Tube, 400 PPD	1	MTH-129-400	17C	Rate Valve Stem & Knob, 200-300 PPD	1	RVH-651-250
4J	Meter Tube, 500 PPD	1	MTH-129-500	17D	Rate Valve Stem & Knob, 400-600 PPD	1	RVH-651-500
4K	Meter Tube, 600 PPD	1	MTH-129-600	PM	Part and Maintenance Kit (4 PPD)	1	KTH-106-4-RMP
5	^{PM} Bottom Meter Gasket, 200-600 PPD	1	GAH-VIT-115	PM	Part and Maintenance Kit (10-100 PPD)	1	KTH-106-RMP
6A	Meter Inlet (4-100 PPD)	1	MIH-232-101	PM	Part and Maintenance Kit (200-250 PPD)	1	KTH-256-RMP
6B	Meter Inlet (200-600 PPD)	1	MIH-232-500	PM	Part and Maintenance Kit (300-600 PPD)	1	KTH-500-RMP
7	^{PM} O-Ring	2	OH-VIT-212				
8A	^{PM} 1/4" NPT 3/8" Tube Tubing Connector	2	BKF-64				106
8B	^{PM} 1/4" NPT 1/2" Tube Tubing Connector	2	BKF-84				200
8C	^{PM} 1/2" NPT 5/8" Tube Tubing Connector	2	BKF-108				256
9	1/2" x 1/4" PVC Reducing Bushing (Required if using 1/4" NPT tubing connectors)	2	839-072				XXX = 300
10	Meter Panel Body	1	MPH-259-500				400
							500
							600



Date: 2019-01-28-v1
 BILL OF MATERIALS
 Dwg. No. MPH-XXX-CL2, BOM

SOH-100-CL2

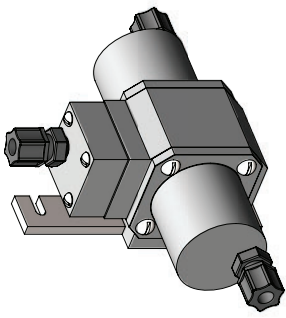

SOH-250-CL2

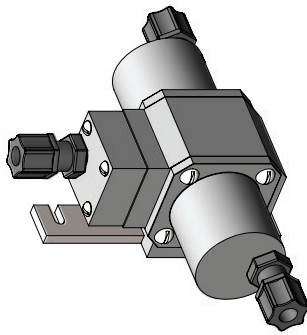

SOH-500-CL2

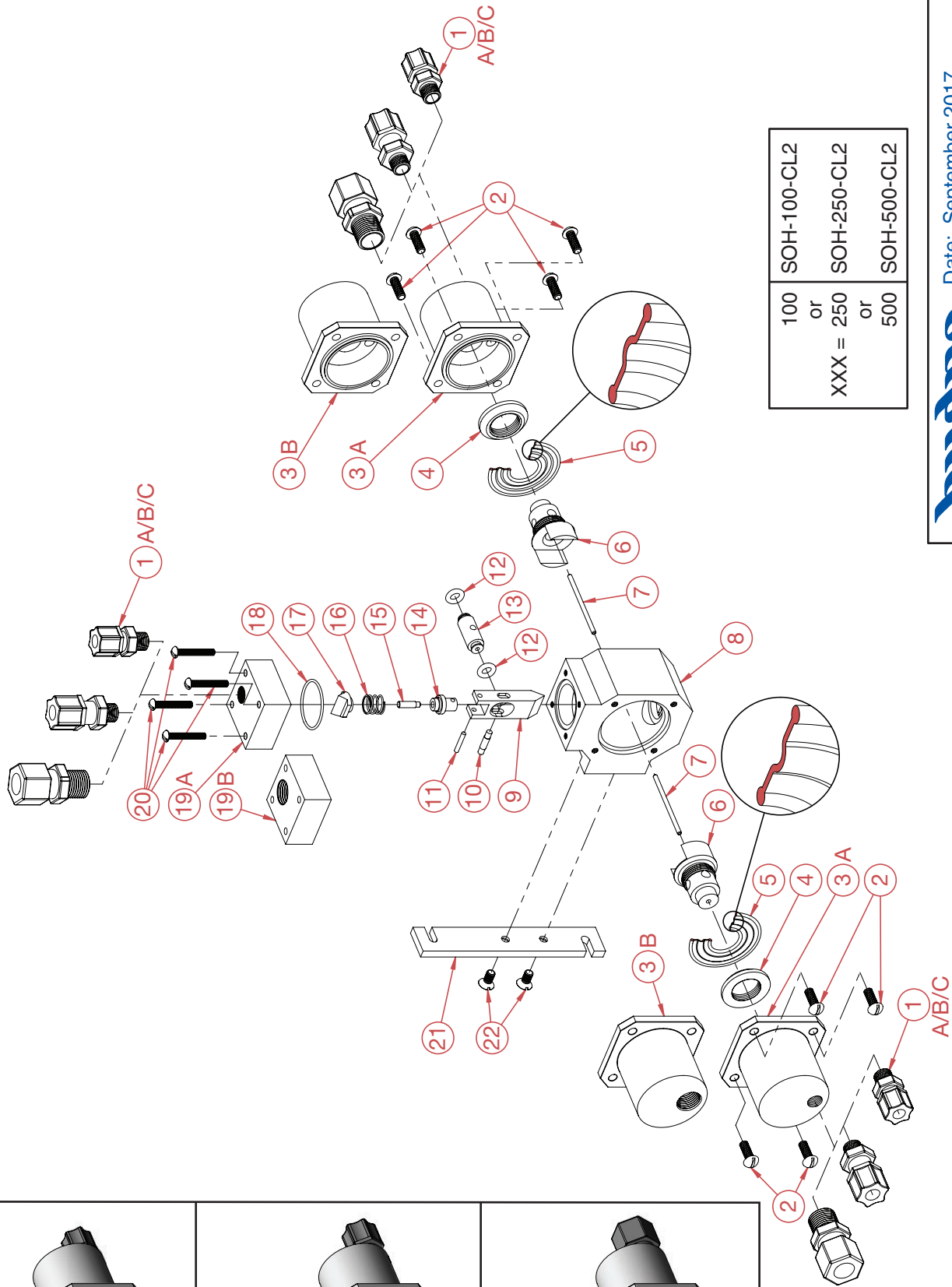
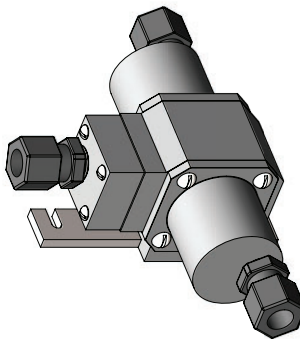

100	SOH-100-CL2
or	
250	SOH-250-CL2
or	
500	SOH-500-CL2



Date: September 2017
EXPLODED VIEW

SWITCHOVER MODULE Dwg. No. SOH-XXX-CL2, EXP

Item No.	Description	Quantity	Part No.
1A	PM1 3/8" Tubing Connector (100 PPD)	3	BKF-64
1B	PM2 1/2" Tubing Connector (250 PPD)	3	BKF-84
1C	PM3 5/8" Tubing Connector (500 PPD)	3	BKF-108
2	1/4"-20 x 3/4" Bolt	8	BTH-STA-189
3A	* ** End Body, 100 & 250 PPD	2	SOH-809-200
3B	*** End Body, 500 PPD	2	SOH-811-500
4	Diaphragm Nut	2	EJH-146-500
5	PM1,2,3 Diaphragm	2	DIH-104-500
6	Diaphragm Bolt	2	SOH-627-500
7	Guide Pin	2	SOH-196-500
8	Center Body	1	SOH-808-500
9	Toggle Spindle	1	SOH-751-500
10	Toggle Pin	1	SOH-168-500
11	Pin	1	SOH-176-500
12	PM1,2,3 O-Ring	2	OH-VIT-203
13	Valve Stud	1	SOH-628-500
14	Pin Pivot	1	SOH-513-500
15	Spring Pivot Pin	1	SOH-278-500
16	Spring	1	SPH-125-000
17	Spring Pivot	1	SOH-277-500
18	PM1,2,3 O-Ring	1	OH-VIT-028
19A	* ** Toggle Cap, 100 & 250 PPD	1	SOH-810-200
19B	*** Toggle Cap, 500 PPD	1	SOH-812-500
20	10-24 x 1 1/4" Bolt	4	BTH-STA-151
21	Switchover Bracket	1	EA-SO-MBR
22	Switchover Bracket Screw (Countersunk)	2	1/4"-20 x 1/2"
PM1	Part & Maintenance Kit (100 PPD)	1	KTH-100-SOM
PM2	Part & Maintenance Kit (250 PPD)	1	KTH-250-SOM
PM3	Part & Maintenance Kit (500 PPD)	1	KTH-500-SOM
*	Only part of the SOH-100-CL2		
**	Only part of the SOH-250-CL2		
***	Only part of the SOH-500-CL2		

100	SOH-100-CL2
or	
XXX = 250	SOH-250-CL2
or	
500	SOH-500-CL2



Date: September 2017
 BILL OF MATERIALS
 Dwg. No. SOH-XXX-CL2, BOM

NOZZLE SIZING CHART (10 PPD)

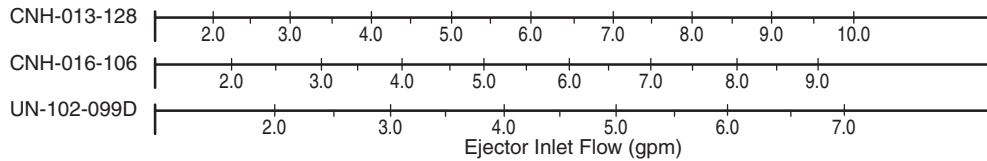
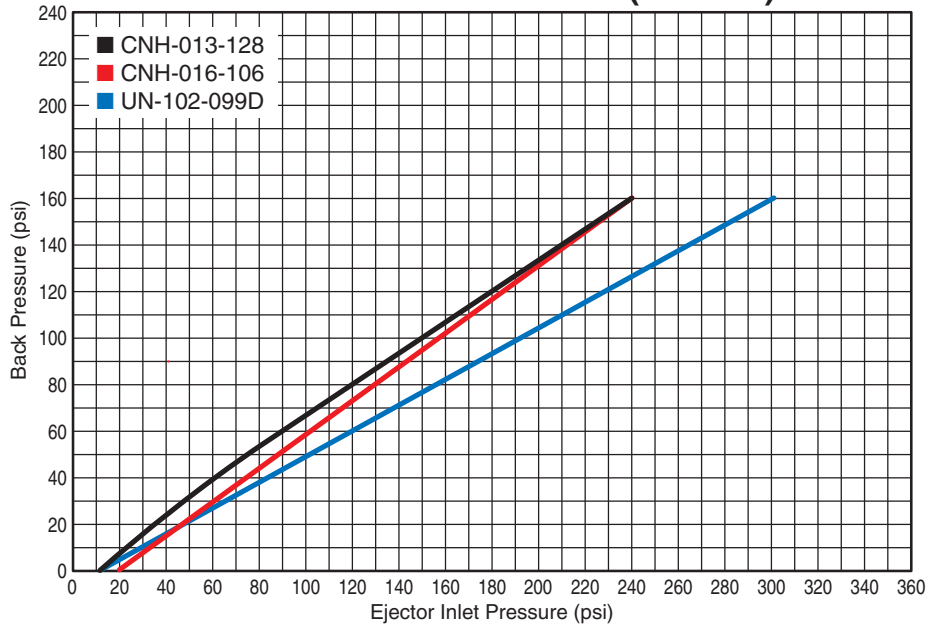

NOZZLE SIZING CHART (25 PPD)

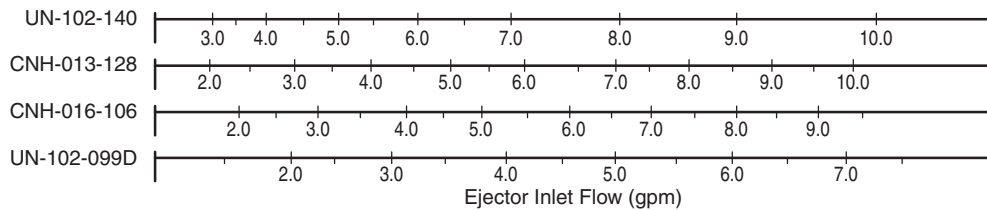
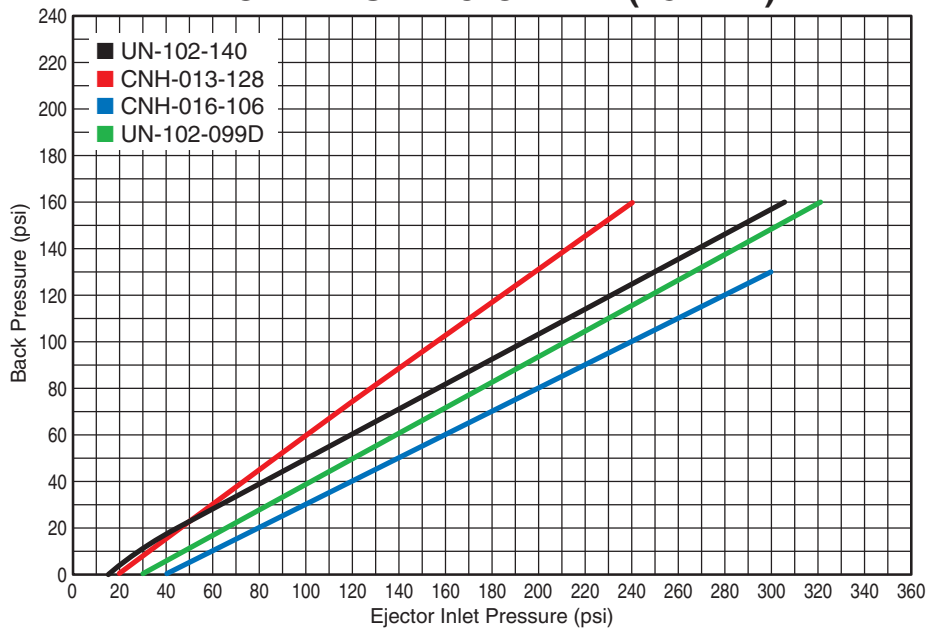

Note: Pressure combinations that plot below the line for any given nozzle are acceptable for operating that nozzle at the stated chemical feed rate for that chart. Pressure combinations that fall above the line for any given nozzle are not acceptable.

NOZZLE SIZING CHART (50 PPD)

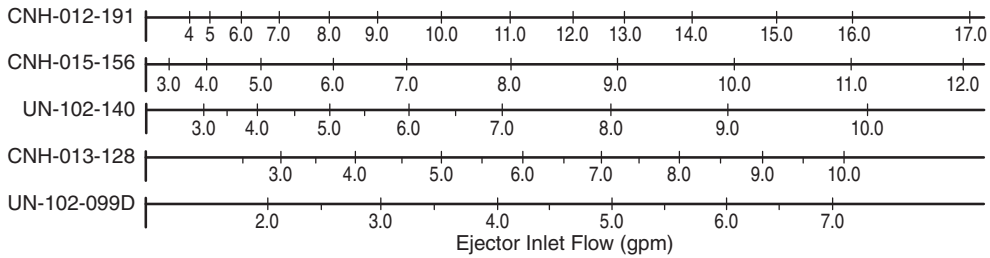
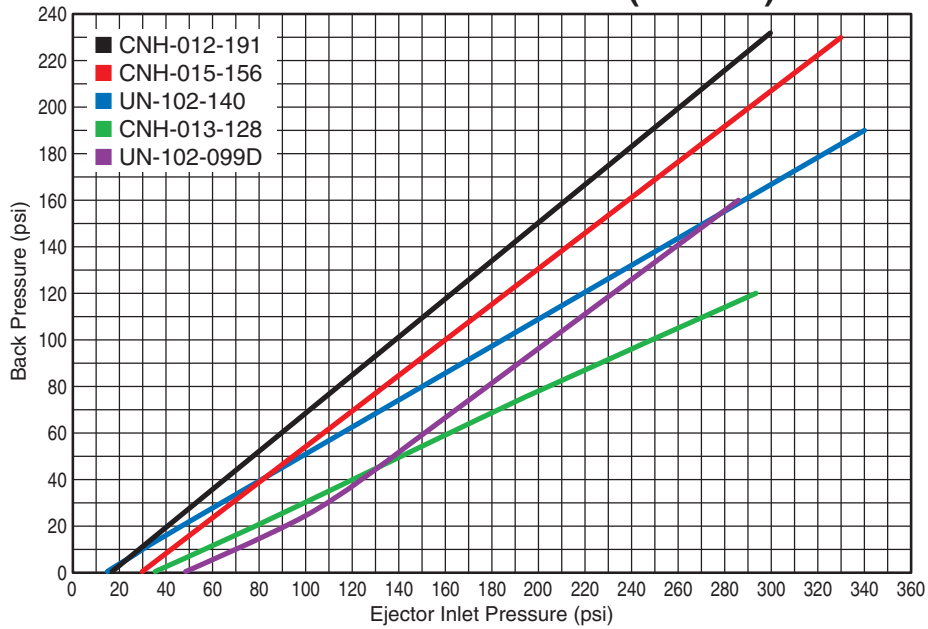

NOZZLE SIZING CHART (100 PPD)

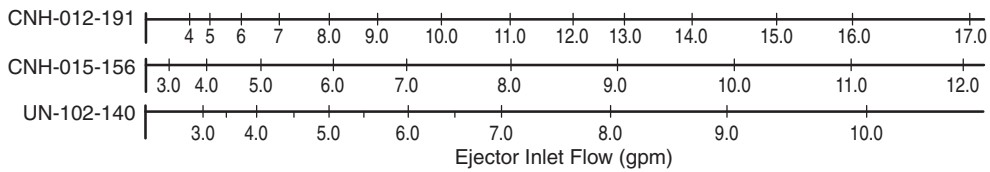
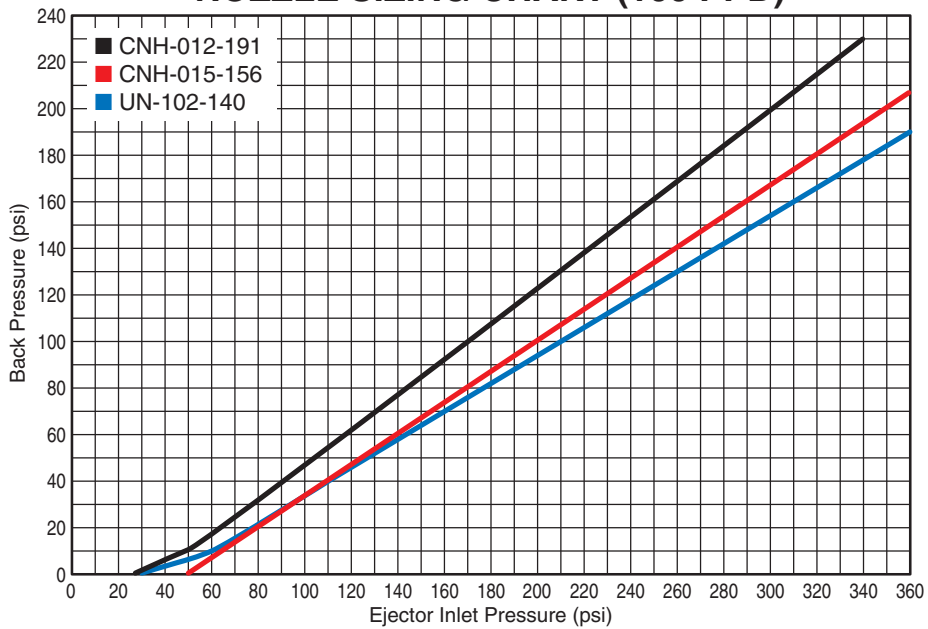

Note: Pressure combinations that plot below the line for any given nozzle are acceptable for operating that nozzle at the stated chemical feed rate for that chart. Pressure combinations that fall above the line for any given nozzle are not acceptable.

NOZZLE SIZING CHART (250 PPD)

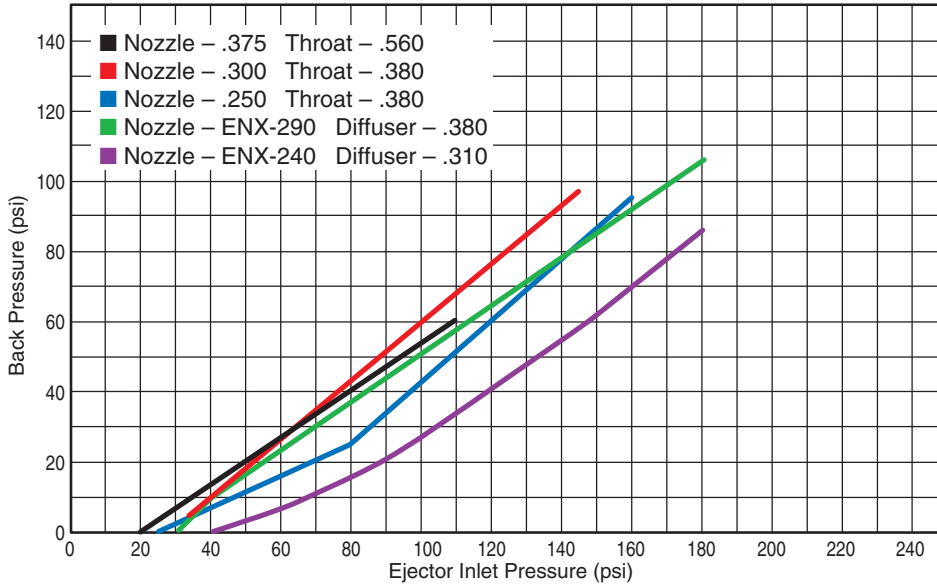

.375 Nozzle



.300 Nozzle or ENX-290



.250 Nozzle or ENX-240

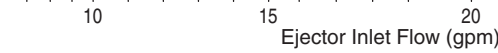

NOZZLE SIZING CHART (500 PPD)

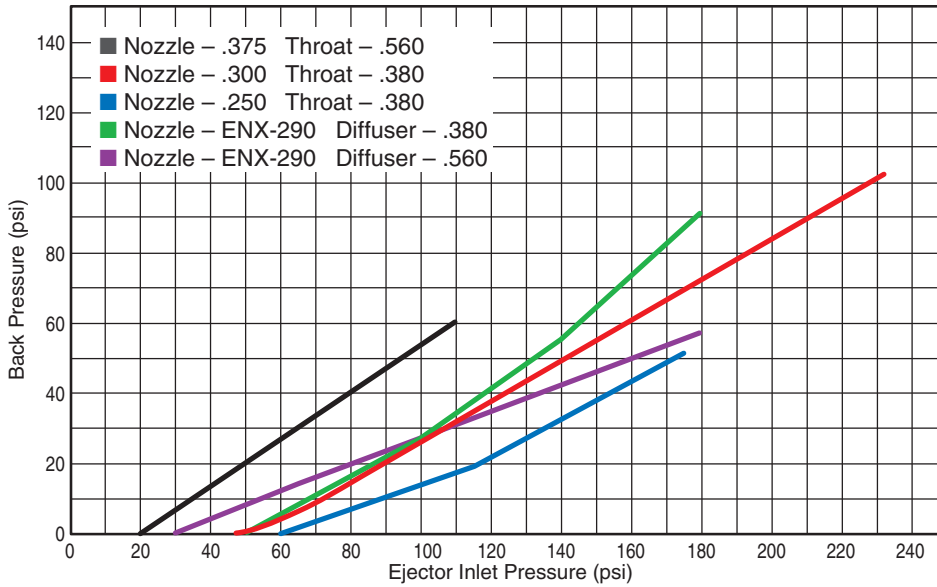

.375 Nozzle



.300 Nozzle or ENX-290



.250 Nozzle or ENX-240

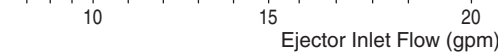

Note: Pressure combinations that plot below the line for any given nozzle are acceptable for operating that nozzle at the stated chemical feed rate for that chart. Pressure combinations that fall above the line for any given nozzle are not acceptable.

NS-250-500 Rev. 3/1/13

Nozzle Tables NST-10-25

10 PPD (200 gr/hr)

Nozzle >	13		UN-102-099D		16	
Ejector Backpressure	PSI @ GPM		PSI @ GPM		PSI @ GM	
0	12	1.7	12	1.2	18	1.5
10	22	1.9	29	1.5	33	2.0
20	35	2.3	47	1.9	48	2.4
30	50	2.8	65	2.3	60	2.7
40	62	3.1	83	2.6	75	3.1
50	76	3.5	101	3.0	90	3.6
60	90	3.9	120	3.4	103	3.9
70	103	4.3	138	3.8	116	4.3
80	120	4.8	156	4.1	130	4.7
90	135	5.2	174	4.5	145	5.1
100	150	5.7	192	4.9	156	5.4
110	165	6.1	210	5.2	171	5.8
120	180	6.5	228	5.6	185	6.2
130	200	7.1	246	6.0	198	6.6
140	210	7.4	264	6.3	213	7.0
150	227	7.9	282	6.7	227	7.4
160	240	8.3	301	7.1	240	7.7

25 PPD (500 gr/hr)

Nozzle >	UN-102-140F		13		UN-102-099D		16	
Ejector Backpressure	PSI @ GPM		PSI @ GPM		PSI @ GPM		PSI @ GPM	
0	15	2.5	20	1.9	30	1.5	40	2.2
10	26	3.0	35	2.3	47	1.9	60	2.7
20	45	3.8	47	2.7	65	2.3	80	3.3
30	63	4.5	60	3.0	84	2.6	100	3.8
40	82	5.2	73	3.4	102	3.0	120	4.4
50	101	5.7	90	3.9	120	3.4	140	5.0
60	119	6.3	100	4.2	139	3.8	160	5.5
70	138	6.6	115	4.6	157	4.1	180	6.1
80	156	7.0	130	5.1	175	4.5	200	6.6
90	175	7.4	143	5.5	193	4.9	220	7.2
100	194	7.9	155	5.8	212	5.3	240	7.7
110	212	8.3	170	6.2	230	5.6	260	8.3
120	231	8.7	185	6.7	248	6.0	280	8.9
130	249	9.0	198	7.0	267	6.4	300	9.4
140	268	9.4	212	7.5	285	6.8	-	-
150	287	9.6	226	7.9	303	7.1	-	-
160	305	9.9	240	8.3	321	7.5	-	-

Nozzle Tables NST-50-100

50 PPD (1 Kg/hr)

Nozzle >	12		15		UN-102-140F		13		UN-102-099D	
Ejector Backpressure	PSI @ GPM		PSI @ GPM		PSI @ GPM		PSI @ GPM		PSI @ GPM	
0	16	4.0	30	4.1	15	2.8	35	2.3	48	1.9
10	28	5.0	41	4.7	28	3.2	55	2.9	70	2.4
20	40	5.8	55	5.1	48	4.0	80	3.6	92	2.8
30	53	6.8	69	5.7	64	4.5	100	4.2	110	3.2
40	65	7.4	81	6.1	82	5.2	120	4.8	124	3.5
50	80	8.0	95	6.6	100	5.7	141	5.4	137	3.7
60	90	8.6	109	6.8	115	6.0	162	6.0	151	4.0
70	102	9.1	120	7.2	132	6.5	183	6.7	164	4.3
80	115	9.6	134	7.6	150	6.9	205	7.3	178	4.6
90	128	10.0	147	7.8	170	7.4	226	7.9	191	4.8
100	140	10.4	160	8.1	185	7.8	247	8.5	205	5.1
110	151	10.8	173	8.4	202	8.1	272	9.2	218	5.4
120	164	11.3	188	8.8	221	8.5	293	9.8	232	5.7
130	175	11.8	200	9.0	239	8.8	-	-	245	5.9
140	190	12.2	213	9.2	255	9.1	-	-	259	6.2
150	200	12.7	226	9.5	273	9.4	-	-	272	6.5
160	212	13.3	240	9.8	290	9.7	-	-	286	6.8

100 PPD (2 Kg/hr)

Nozzle >	12		UN-102-140F		15	
Ejector Backpressure	PSI @ GPM		PSI @ GPM		PSI @ GPM	
0	27	5.0	30	3.3	50	5.1
10	50	6.7	60	4.4	65	5.4
20	65	7.3	79	5.0	80	6.1
30	78	8.0	95	5.6	95	6.5
40	91	8.6	110	6.0	110	7.0
50	105	9.2	126	6.4	125	7.2
60	117	9.7	145	6.9	140	7.6
70	131	10.1	160	7.2	155	7.9
80	142	10.5	180	7.5	170	8.3
90	158	11.0	195	7.9	185	8.7
100	170	11.5	210	8.2	200	9.0
110	183	12.0	229	8.5	213	9.3
120	197	12.7	243	8.9	228	9.5
130	210	13.2	260	9.2	244	9.9
140	222	13.7	279	9.5	260	10.2
150	235	14.0	295	9.8	275	10.4
160	250	14.5	310	10.0	291	10.8

Nozzle Tables NST-250-500

250 PPD (5 Kg/hr)

Nozzle >	0.375		0.300		ENX-290		0.250		ENX-240	
Throat >	0.560		0.380		0.380		0.380		0.310	
Ejector Backpressure	PSI @ GPM		PSI @ GPM		PSI @ GPM		PSI @ GPM		PSI @ GPM	
0	20	15.0	-	-	30	11.5	25	7.5	40	9.0
10	35	20.0	40	14.0	40	13.2	47	10.5	67	12.9
20	50	25.0	52	15.0	55	15.5	68	12.5	89	14.6
30	65	28.0	65	16.7	70	17.5	85	14.5	114	16.2
40	80	32.0	77	18.2	84	19.5	98	16.0	119	17.8
50	95	34.0	87	19.7	98	20.9	108	17.0	132	19.1
60	110	38.0	100	21.0	113	22.1	119	18.0	148	19.8
70	-	-	113	22.3	128	23.8	130	19.0	160	20.0
80	-	-	125	23.3	142	25.0	143	19.6	172	21.5
90	-	-	137	24.5	158	26.2	155	20.3	-	-
100	-	-	148	25.4	171	27.0	-	-	-	-
110	-	-	160	26.3	-	-	-	-	-	-

500 PPD (10 Kg/hr)

Nozzle >	0.375		0.300		ENX-290		ENX-290		0.250	
Throat >	0.560		0.380		0.560		0.380		0.380	
Ejector Backpressure	PSI @ GPM		PSI @ GPM		PSI @ GPM		PSI @ GPM		PSI @ GPM	
0	20	15.0	48	15.0	30	10.0	50	15.0	60	11.9
10	35	20.0	72	18.0	52	15.3	67	17.5	90	14.5
20	50	25.0	88	20.1	82	19.3	85	20.0	115	17.5
30	62	27.0	105	22.0	107	22.8	105	22.1	135	19.0
40	80	32.0	123	24.0	135	25.5	118	23.9	155	20.4
50	96	34.0	140	25.5	160	26.5	132	25.0	172	21.5
60	110	38.0	160	26.7	185	28.0	145	25.8	-	-
70	130	41.0	175	27.3	-	-	157	26.5	-	-
80	145	44.0	192	28.5	-	-	168	27.0	-	-
90	-	-	210	29.2	-	-	180	27.8	-	-
100	-	-	228	31.0	-	-	-	-	-	-