

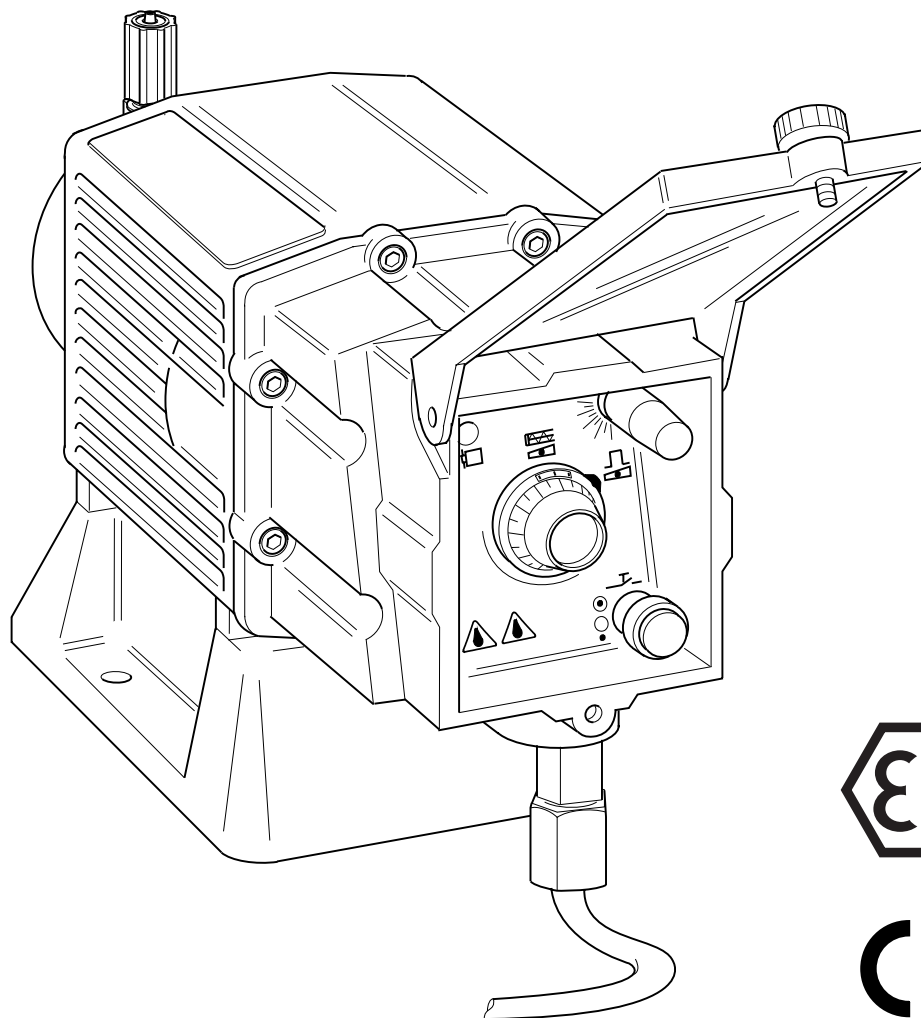

Operating Instructions

Metering Pump ProMinent EXtronic® EXBb



EXBb

Please enter identcode of the device here!

**The operating instructions contain changes in the electrical safety parameters.
It replaces all earlier operating instructions.**

**Please carefully read through these operating instructions in full! Do not discard!
The operator shall be liable for any damage caused by installation or operating errors!**

Publishing details:

Operating Instructions Metering Pump ProMinent EXtronic® EXBb
© ProMinent Dosiertechnik GmbH, 2003

ProMinent Dosiertechnik GmbH
Im Schuhmachergewann 5-11
69123 Heidelberg
Germany
info@prominent.com
www.prominent.com

Subject to technical modificatios.

View of Metering Pump

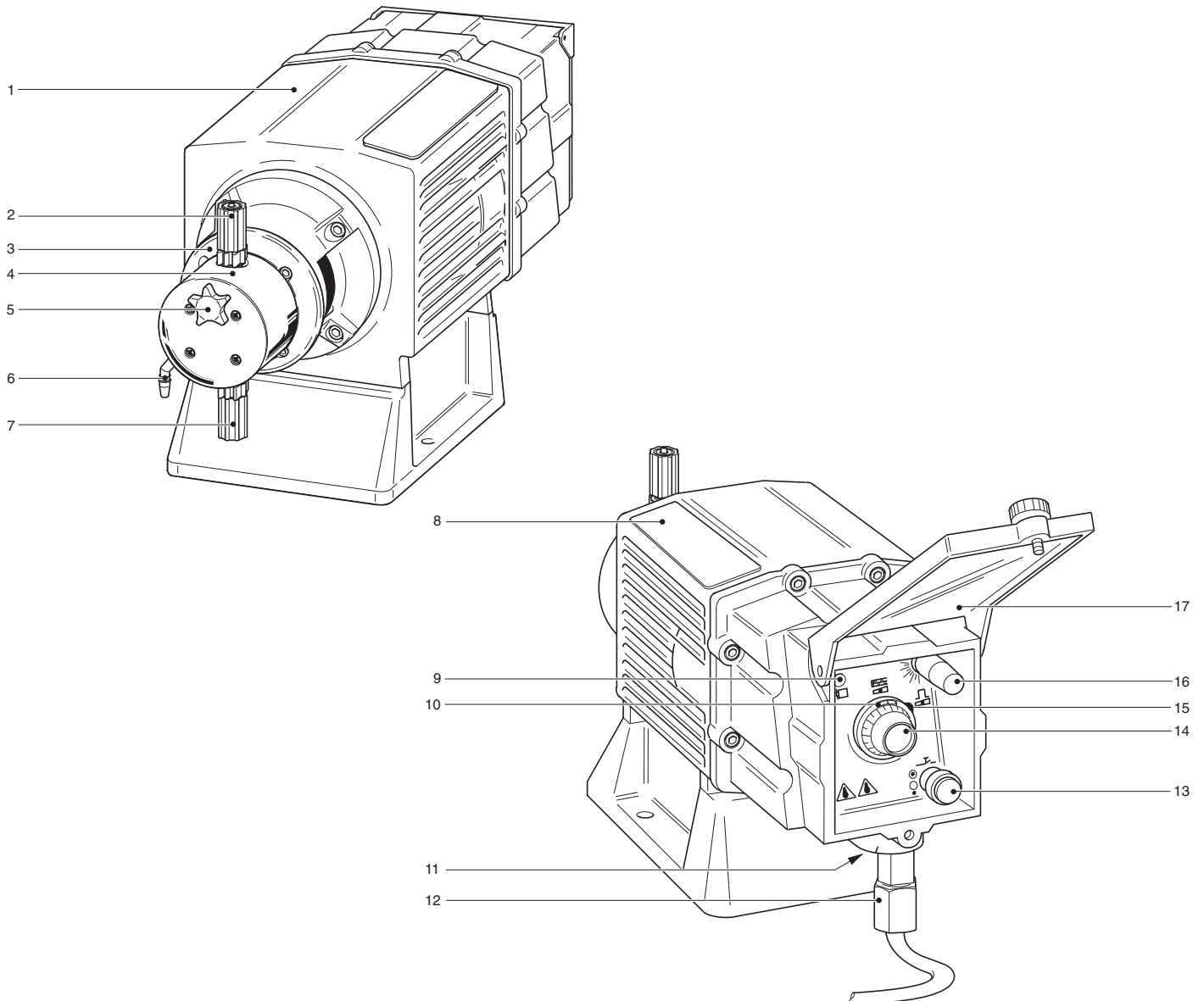

Description of Functional Elements

- 1 Drive unit with electronic control and solenoid
- 2 Delivery connection
- 3 End ring
- 4 Liquid end
- 5 Vent valve (only on types 1000 - 0417 NP and PP, refer to identcode on Page 13)
- 6 Socket for bypass hose (only on types 1000 - 0417 NP and PP, refer to identcode on Page 13)
- 7 Intake connection#
- 8 Type identification plate
- 9 Operating/impulse display
- 10 Inspection window
- 11 External connection
- 12 Power connection
- 13 Mains switch (not for 500 V version)
- 14 Control for stroke length
- 15 Locking lever
- 16 Control knob for stroke rate or pushbutton/pushbutton switch for priming
- 17 Transparent cover

Contents

View of Metering Pump	3
Description of Functional Elements	3
Notes for User	7
Metering Pump Applications	8
1 Safety	9
1.1 Notes on Safety	9
1.2 Reference Guidelines/Standards	9
1.3 Tests and Approvals	10
2 Design and Function	10
2.1 Functional principle	10
2.2 Construction / functional description, diaphragm rupture detector	10
2.3 Delivery capacity	11
2.4 Versions	12
3 Technical Data	13
3.1 Identcode	13
3.2 Dimensions and Weights	14
3.3 Capacity data	15
3.4 Accuracies	16
3.5 Material Specifications	16
3.6 Electrical Data	16
3.6.1 Electrical data, control current circuit	16
3.6.1.1 for “non-intrinsically safe” version and “intrinsically safe” version	16
3.6.1.2 under “intrinsically safe” version	17
3.6.2 Electrical data, supply current circuit	17
3.6.2.1 for “not intrinsically safe” version	17
3.6.2.2 for the “intrinsically safe” version	17
3.6.3 Electrical data for the intrinsically safe (optional) diaphragm rupture indicator	18
3.6.4 Electrical data, details	18
3.7 Mechanical data, cables	18
3.8 Ambient conditions	19
4 Unpacking	19
5 Mounting and Installation	20
5.1 Installing Metering Pump	20
5.2 Installing Hose Lines	20
5.2.1 Installing the Intake Line	21
5.2.2 Installing the Delivery Line	22
5.2.3 Installing the Bypass Vent Line (see fold-out page)	22
5.3 Installation Examples, Mechanical/Hydraulic	23
5.4 Electrical Installation	25

6 Operation	26
6.1 Start-Up	26
6.2 Determining the Delivery Capacity	27
6.3 Nomograms	29
6.4 Setting the Delivery Capacity	37
7 Maintenance	37
8 Repairs	38
8.1 Replacing working diaphragm / safety diaphragm	38
8.2 Servicing diaphragm rupture detector	39
8.3 Replacing separating diaphragm in the diaphragm rupture detector	39
8.4 Checking diaphragm rupture detector	39
9 Malfunctions	40
9.1 Operation/pulse indicator does not light, no stroke movement	40
9.2 Pump intake no longer operable despite full stroke movement and venting	40
9.3 Pump no longer meters, although operation/pulse indicator lights	40
9.4 Liquid Emerges from end ring	40
9.5 Pump does not reach high pressures or no suction despite max. stroke action	42
9.6 Diaphragm rupture indicator triggers alarm	42
10 Used Part Disposal	42
11 Spare parts	43
Installation data	46
Guarantee claim for metering pumps	47
Declaration of Complete Safety	48
EC Declaration of Conformity	49
EC Model Certificate	50

Notes for User

Please read the following instructions carefully. They will help you make the best use of this manual.

The following are highlighted in the text:

- Numbered points
- ▶ Instructions

Operating guidelines:

NOTE

Notes are intended to make your work easier.

and safety instructions:



WARNING

**Describes a potentially hazardous situation.
If not avoided may result in fatal or severe injury.**



CAUTION

**Describes a potentially hazardous situation.
If not avoided, could result in slight or minor injury or damage to property.**



IMPORTANT

**Describes a potentially damaging situation.
If not avoided may result in damage to property.**

Metering Pump Applications

The ProMinent EXtronic® EXBb is an electronically controlled, explosion-proof diaphragm metering pump with a short-stroke solenoid.

Liquid media

The pump is used for metering liquid media:

- in explosion-threatened workplaces in zone 1, device category II 2 G of explosion group II C (EXBbG) according to VDE guidelines
- for firedamp-threatened underground excavations in explosion group I, device category 1 M 2 (EXBbM) according to VDE guidelines
- in industrial premises at risk of explosion according to FM and CSA standards

Liquid ends made of various materials cover virtually all applications:

- Polypropylene (PP)
- PVC
- Acrylic
- PTFE-Teflon®
- Stainless steel

Gas-emitting media

Self-venting liquid ends made of Acrylic or PVC are available for metering gas-emitting media.

Combustible media



WARNING

For combustible media only use the "SB" dosing head.



IMPORTANT

The pump is not designed to meter gaseous media as well as solids.

Voltages

Versions are available for various voltages and frequencies:

230 V, 115 V, 500 V, 100 V und 200 V;
50/60 Hz.

Compatibility

The ProMinent EXtronic® EXBb is a continuation of the former EXBa series:

The external dimensions and securing holes are identical and the hydraulic accessories of these series can be used.

The liquid ends are compatible with the other diaphragm metering pumps, with the exception of versions „SB _“ and „_ _ M“ (see Identcode page 13).

1 Safety

1.1 Notes on Safety



WARNING

- Immediately switch off the pump in the case of emergency!
Use the pump power switch or an emergency stop switch in your working environment!
- When installing the metering pump also observe the installation instructions for devices in explosive areas; for Europe the European operator directive 99/92/EC (ATEX137) and the ATEX Product Directive 94/9/EC (ATEX 95), implemented in Germany by the new health and safety legislation!
- When using the metering pump for metering flammable media, observe (in Europe) the European Operator Guideline 99/92/EC (ATEX 137, previously ATEX118a), implemented in Germany with the new operating safety directive and the German dangerous chemicals directive.
- Observe also all relevant standards e.g. DIN EN 60079-10/14 and DIN VDE 60079-11 for installations in explosion-threatened areas and DIN VDE 0118 for the installation of electrical equipment in explosion-threatened areas by day.
- Note all national directives which apply to the installation when installing outside Germany.



CAUTION

- Pumps must be accessible at all times to facilitate operation and maintenance.
Do not obstruct or block access routes!
- Only specially trained and authorized persons are permitted to maintain and repair metering pumps and their peripheral equipment!
- Always depressurize the liquid end first before carrying out any work on the pump!
- If hazardous or unknown metering media are used, discharge and flush the liquid end before carrying out any work on the pump!
- Observe the safety data sheets of the metering liquids!
- Always wear protective clothing (goggles, gloves) when handling hazardous or unknown liquids! This applies in particular to working on the liquid end!
- Assembly of ProMinent® metering pumps with parts not tested and approved by ProMinent is prohibited and can result in damage to persons and property, for which no liability will be accepted!



IMPORTANT

- Adjust the stroke length only with the pump running when the load on the stroke length setting pin is relieved temporarily!
Release the lock before adjusting the stroke length!
- Only use clamping rings and hose sockets suitable for the relevant hose diameter as well as genuine ProMinent hoses with the specified hose dimensions and wall thickness, otherwise the stability of the connection cannot be guaranteed!

NOTE

- Avoid reducing the hose sizes!
- Use the next higher pipe cross-section or a pulsation damper for long hose lines and media with higher viscosity!

1.2 Reference Guidelines/Standards

see EC conformity declaration

1.3 Tests and Approvals

Explosions protection

The conformity certificate of the DMT-Gesellschaft für Forschung und Prüfung mbH, department for the safety of electric resources, exploring drifts, can be found in the appendix.

Device type	Identification mark	Approval
EXBbG	II 2G Ex d IIC T6 Gb	II 2G c IIC T6 Gb DMT 03 ATEX E 023
EXBbG, intrinsically safe	II 2(1)G Ex d [ja Ga] IIC T6 Gb	II 2G c IIC T6 Gb DMT 03 ATEX E 023
EXBbM	I M2 Ex d I Mb	I M2 c I Mb DMT 03 ATEX E 023
ExBbM, intrinsically safe	I M2(M1) Ex d [ja Ma] I Mb	I M2 c I Mb DMT 03 ATEX E 023
EXBbG	Class I, Div.1, Group B, C and D, T6	FMR
EXBbG	Class I, Div.1, Group B, C and D, T6	CSA

2 Design and Function

You will find the view of the metering pump and the description of the function units on the fold-out page of the cover.

The metering pump ProMinent EXtronic® consists of the main components

Drive unit (1)

With electronic control and solenoid,
power connection (10)
Input "external control" (optional) (11);

Delivery unit

End ring (3) with diaphragm which is stabilised by a steel core.
Liquid end (4) with delivery connection (2) and intake connection (7),
on types 1000-0417 NP and PP with bypass hose socket (6) and vent valve (5);

Operator control unit

with operating/pulse display (9),
Mains switch (not for 500 V version) (13),
Stroke length control knob (14) with observation window (10),
Locking lever (15),
Control knob for stroke rate or pushbutton/pushbutton switch for priming (16) and transparent cover (17).

2.1 Functional principle

Metering is based on the pulse burst principle:

A pulse produces a magnetic field around the solenoid,
the solenoid attracts a moving thrust piece,
as a result, the diaphragm displaces the medium in the liquid end via a pressure control valve,
the valve closes on the intake side.

The magnetic field decays on completion of the switch-on pulse,
the thrust piece of the solenoid is reset by a reset spring,
the diaphragm returns to its initial position, thus initiating an intake stroke,
which closes the pressure valve and the media is drawn in on the intake side.

2.2 Construction / functional description diaphragm rupture indicator (optional)

The diaphragm rupture signalling system monitors the leak-tightness of the operating diaphragm.

The liquid end of EXBb with diaphragm rupture signalling has instead of only one operating diaphragm an additional diaphragm comprising the operational diaphragm and an additional safety diaphragm, and is equipped with an intrinsically safe diaphragm rupture sensor (see figure 1).

The safety diaphragm is situated between the top plate and the spacer plate and forms a sealed interim chamber with the working diaphragm.

Function It serves to monitor ruptures in the working diaphragm and protects the power end from corrosion and the environment from chemical leaks in the case of diaphragm rupture. Even after diaphragm rupture, this liquid end can continue to operate in emergency mode at full working pressure and without leaks until the diaphragm is changed.

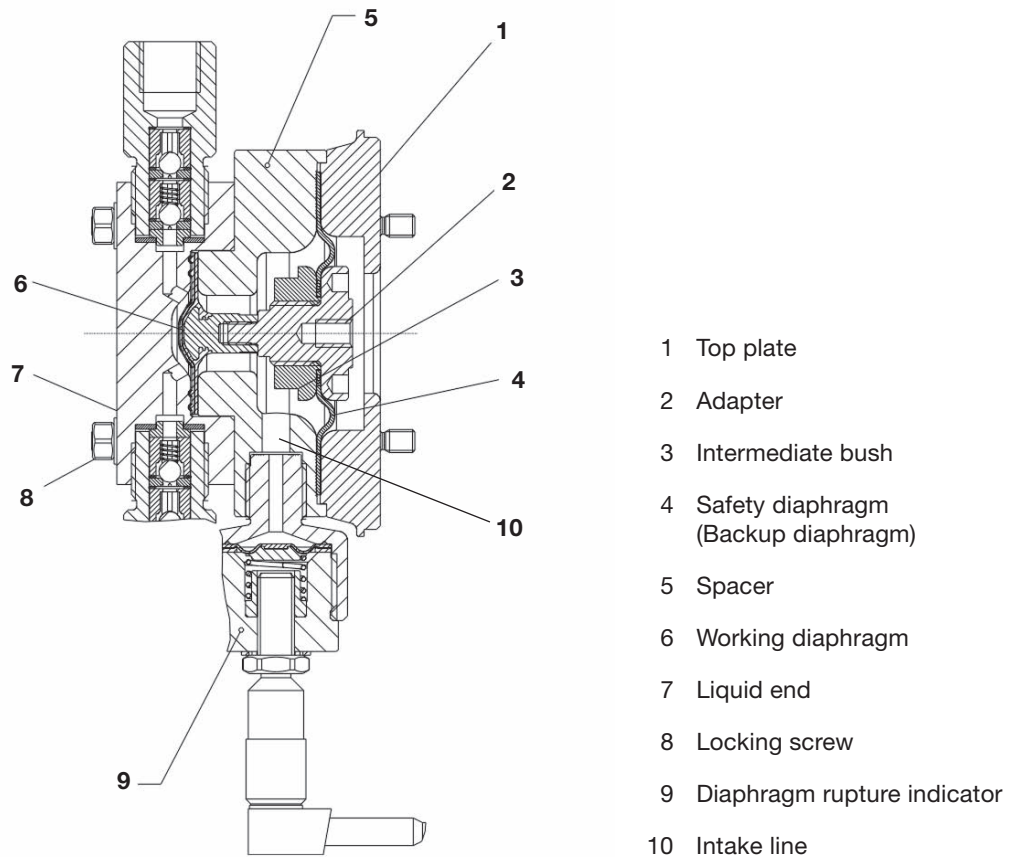

fig.: 1



IMPORTANT

If the diaphragm ruptures, an electrical signal is triggered when the system back pressure reaches approx. 2 bar.



IMPORTANT

Precise pump feed cannot be guaranteed after a working diaphragm rupture.

2.3 Feed rate

The delivery capacity is determined by the stroke length and the stroke frequency (rate). The stroke length can be steplessly adjusted with the control knob for stroke length (14) during operation from 100 % to 10 % and then locked. The maximum stroke length is 1.25 mm, 0.63 mm for type EXBb_1000.

A setting of 0 to 110 (120) stroke/min can be set manually with the control knob for stroke frequency (rate) (16).

At a maximum stroke length and rate and a max. backpressure of 1.5 bar to 25 bar, the diaphragm-operated metering pumps deliver at a rate of 0.2 l/h to 60 l/h.

2.4 Control types

Version “Internal stroke rate setting” (identity code characteristic “Control type”: 0):

The controlling pulse is internally generated, stroke length and stroke rate can be manually adjusted using the control buttons on the operating panel.

Versions “External contact control” (identity code characteristic “Control type”: 1, 4):

The controlling pulse is externally generated, from potential-free or semiconductor contacts and fed to the drive unit via the “external control” jack; examples are contact water meter or DULCOMETER® controls.

Versions “Analog control x - 20 mA”

(Identity code characteristic “Control type”: 2, 3, 5, 6):

An external, analogue signal is fed to the drive unit via the “External control” jack; the stroke rate changes proportionally according to the 0 .. 20 mA or 4 .. 20 mA signal.

Versions “Internal stroke rate setting with pause function”

(Identity code characteristic “Control type”: 7, 8):

As for version “Internal stroke rate setting”, however there is also the possibility of switching the metering on and off via an external semiconductor contact or potential-free contact.

NOTE

All control types, that can be controlled via an input, can be supplied with an “External control” input of “non-intrinsically safe” or “intrinsically safe” type [i, a].

3.2 Dimensions and Weights

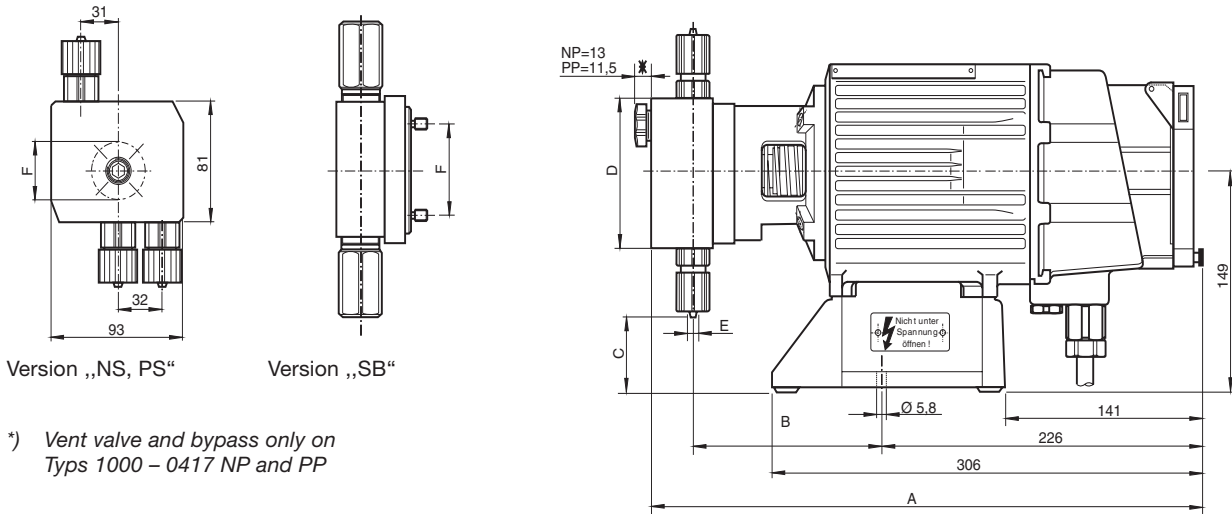
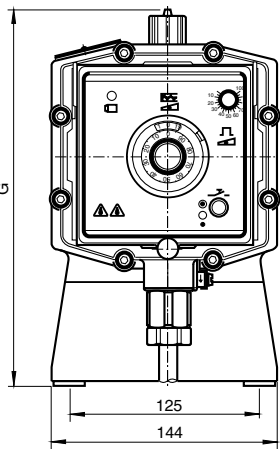

fig.: 2

*) Vent valve and bypass only on Typs 1000 – 0417 NP and PP



ProMinent EXtronic® EXBb		dimensions in mm						
Pump type / material		A	B	C	ø D	E	ø F	G
1000,1601, 1201, 0803	NP1	391	136	69	70	6x4	38	229
1002, 0308, 2502, 2505, 1006	NP3	391	136	61	85	8x5	50	237
1310, 0613		391	136	52	100	8x5	66	244
0814, 0417		391	136	52	100	12x9	66	244
0430		381	137	46	135	DN10	117	304
0260		398	142	-16	135	DN15	117	314
1000, 1601, 1201, 0803	PP1	393	136	67	70	6x4	38	236
1002, 0308, 1006		393	136	67	70	8x5	50	236
0613		393	136	57	90	8x5	66	246
0814, 0417		393	136	57	90	12x9	66	246
0430		381	137	46	135	DN10	117	304
0260		398	142	-16	135	DN15	117	314
1002	PP4	389	138	46	85	DN10	50	222
1006		398	145	76	85	DN15	50	222
1310		398	145	76	85	DN15	66	222
0814		398	145	69	100	DN15	66	229
1000, 1601, 1201	TT1	378	134	75	60	6x4	38	223
0803		378	134	70	70	6x4	38	228
1002, 0308, 1006		388	138	42	80	8x5	50	256
0613		388	138	32	95	8x5	66	266
0814, 0417		388	138	32	95	12x9	66	266
0430		388	137	35	135	DN10	117	263
0260		398	142	31	135	DN15	117	268
1000, 1601, 1201	SS1	376	134	84	60	6x5	38	214
0803		376	134	79	70	6x5	38	219
1002, 0308, 2502, 2505, 1006		386	138	48	80	8x7	50	250
1310, 0613		386	138	39	95	8x7	66	259
0814, 0417		386	138	39	95	12x10	66	259
0430		386	137	35	135	DN10	117	263
0260		390	142	28	135	DN15	117	271
1601, 2501	SSM	391	149	84	60	6x5	38	214
1000	SB1	373	134	87	70	Rp 1/4	38	211
1601, 1201, 0803		373	134	79	85	Rp 1/4	38	219
1002, 0308, 2502, 2505, 1006		381	138	56	80	Rp 1/4	50	242
1310, 0613		381	138	48	95	Rp 1/4	66	250
0814, 0417		381	138	48	95	Rp 1/4	66	250
0430		381	138	22	145	Rp 1/4	117	275
0260		383	139	27	145	Rp 1/2	117	279
1601, 2501	SBM	388	149	79	85	Rp 1/4	38	219

*) see diagram

1601, 1201, 0803	NS3	383	136	67	*	6x4	38	243
1002		383	136	67	*	6x4	50	243
1601, 1201, 0803	PS3	383	136	67	*	6x4	38	243
1002		383	136	67	*	6x4	50	243

Pump type	Material	Weight	
		EXBbG	EXBbM
1000, 2501, 1601, 1201, 0803, 1002, 0308	NP, PP, TT, SS, SB	approx. 12/16 kg	approx. 26/30 kg
2502, 1006, 0613, 0417	NP, PP, TT, SS, SB	approx. 13/17 kg	approx. 27/31 kg
2505, 1310, 0814, 0430, 0260	NP, PP, TT, SS, SB	approx. 16/20 kg	approx. 30/34 kg

3.3 Capacity data

Pump type	max. Capacity at max. backpressure			max. Capacity at medium backpressure			Stroke rate strokes/min	Connection-size ä Ø x i Ø	Suction lift* m Wc	Priming lift** m Wc	Perm. ad- mission pres. intake side bar
	EXBb	bar	l/h	ml/stroke	bar	l/h					
1000	10	0.19	0.27	5	0.27	0.038	120	6x4	1.5	0.5	8.0
2501 SSM	25	1.14	0.16	12	1.4	0.18	120	6x4	5	1.8	8.0
1601 SSM	16	1.31	0.18	8	1.68	0.23	120	6x4	5	1.8	8,0
1601	16	1.00	0.14	8	1.3	0.18	120	6x4	5	1.8	8.0
1201	12	1.70	0.24	6	2.0	0.28	120	6x4	5	2.5	5.5
0803	8	3.70	0.51	4	3.9	0.54	120	6x4	5	2.8	3.0
1002	10	2.30	0.32	5	2.7	0.38	120	8x5	5	1.0	3.0
0308	3	8.60	1.20	1.5	10.3	1.43	120	8x5	5	1.8	1.5
2502	25	2.00	0.28	12	2.4	0.31	120	8x5	5	1.0	8.0
2505	25	4.20	0.64	12	5.3	0.73	110	8x5	5	1.5	3.5
1006	10	6.00	0.83	5	7.2	1.00	120	8x5	5	1.3	3.5
1310	13	10.50	1.59	6	11.9	1.80	110	8x5	5	1.9	2.0
0613	6	13.10	1.82	3	14.9	2.07	120	8x5	5.5	1.9	2.0
0814	8	14.00	2.12	4	15.4	2.33	110	12x9	5	2.0	1.5
0417	3.5	17.40	2.42	2	17.9	2.49	120	12x9	4.5	2.0	1.5
0430	3.5	27.00	4.09	2	29.5	4.7	110	DN10	5	1.8	0.8
0260	1.5	60.00	9.09	-	-	-	110	DN15	1.5	1.5	0.8

Type 1000

Type 2502, 2505, 1310 only in version NP and SS

Metering pumps for high viscosity media "HV"

EXBb	bar	l/h	ml/stroke	bar	l/h	ml/stroke	strokes/min	mm	m Wc	m Wc	bar
1002	10	2.30	0.31	5	2.7	0.38	120	DN10	1	-	3.0
1006	10	6.00	0.83	5	7.2	1.00	120	DN15	1.3	-	3.5
1310	10	10.50	1.59	6	11.9	1.80	110	DN15	1.9	-	2.0
0814	8	14.00	2.12	5	15.4	2.33	110	DN15	2	-	1.5

Metering pumps with self-degassing liquid end***

EXBb	bar	l/h	ml/stroke	bar	l/h	ml/stroke	strokes/min	mm	m Wc	m Wc	bar
1601	16	0.66	0.09	-	-	-	120	6x4	-	1.8	0.2
1201	12	1.0	0.14	-	-	-	120	6x4	-	2.0	0.2
0803	8	2.4	0.33	-	-	-	120	6x4	-	2.8	0.2
1002	10	1.8	0.25	-	-	-	120	6x4	-	2.0	0.2

*) Suction lift: with intake line filled

**) Priming lift: with intake line not filled

***) The specified performance data are guaranteed minimum values determined with water at room temperature.

3.4 Accuracies

min.: -5 %, max.: not specified
at max. stroke length and max. backpressure,
in all material versions.

Better than $\pm 2\%$
under constant conditions and min. 30 % stroke length;
observe following notes:

- All specifications refer to metering measurements with water at 20 °C.
- Constant backpressure, above 1 bar if possible.
- If metering takes place via a free outlet, a pressure retention valve must be used to generate a backpressure of min. 1.5 bar (refer to the installation examples).
- Wherever possible, lay intake and metering lines with a constant rising gradient.
- If the liquid level of the supply tank is above the pump during operation, admission pressure will be applied on the intake side; in this case, the backpressure should be so high that there is a minimum differential pressure of 1.5 bar otherwise a pressure retention valve or a spring-loaded injection valve with corresponding admission pressure must be used.

NOTE

A pressure retention valve or a spring-loaded injection valve is not an absolutely tight-closing shut-off element. For this reason, an intake valve which is closed when the metering pump is at a standstill, must be installed if admission pressure is applied on the intake side.

3.5 Material Specifications

	PP1	PP4	PC5	NP1/NP3	NS3	PS3	TT1	SS
<i>Liquid end</i>	Polypropylene	Polypropylene	PVC	Acrylic	Acrylic	PVC	PTFE with carbon	Stainless steel 1.4404
<i>Intake- / delivery connection</i>	Polypropylene	Polypropylene	PVC	PVC	PVC	PVC	PTFE with carbon	Stainless steel 1.4404
<i>Seals</i>	EPDM	EPDM	FPM-A	FPM-A/B	FPM-B	FPM-B	PTFE	PTFE
<i>Balls Ø 6–Ø 12</i>	Ceramic	—	Ceramic	Ceramic	Ceramic	Ceramic	Ceramic	Ceramic
<i>Balls DN10–DN15</i>	Duran	Ceramic	—	Duran	—	—	Ceramic	1.4401

Type 1000 with ceramic seat rings in all material versions
PP4 with Hastelloy C valve springs
DEVELOPAN® metering diaphragm with PTFE base in all versions
FPM-A (Viton®-A), FPM-B (Viton®-B) and Duran (laboratory glass) are registered trademarks.

3.6 Electrical Data

3.6.1 Electrical data, control current circuit

3.6.1.1 for “non-intrinsically safe” version and “intrinsically safe” version

mA input, identity code feature “control type”: 2, 3, 5*, 6*

Voltage max.	6 V
Current max.	30 mA
Input apparent ohmic resistance, approx.	94 Ω

Contact/pause input, identity code feature "control type": 1, 4*, 7, 8*

Voltage with open contact approx. 5 V

Input resistance approx. 4.7 kΩ

Control using potential-free contact or semiconductor switch:

Residual current max. (contact open): 70 μA

Contact resistance (closed) max.: 10 kΩ or

Voltage drop max.: 3 V

Pulse frequency max.: 40 pulses/sec.

Pulse width min.: 10 ms

* For the ensuring of intrinsic-safety, see chapter 3.6.1.2 under "intrinsically safe" version

3.6.1.2 under "intrinsically safe" version

Control circuit

Default value of all types "(ia)",

- Maximum output voltage: $U_0 = 7.14 \text{ V}$
- Maximum output current: $I_0 = 5 \text{ mA}$
- Maximum output power: $P_0 = 23.3 \text{ mW}$
- Internal resistance $R_i = 4296 \text{ } \Omega$
- Maximum external inductance: $L_0 = 1 \text{ H}$
- Maximum external capacity: $C_0 = 13.5 \text{ } \mu\text{F}$

For connection of an intrinsically safe circuit

- Maximum input current: $I_i = 280 \text{ mA}$
- Maximum input voltage: $U_i = 30 \text{ V}$
- Maximum input power $P_i = 2 \text{ W}$
- Effective inner self-inductance $L_i = \text{negligible}$
- Effective inner capacity $C_i = \text{negligible}$

3.6.2 Electrical data, supply current circuit

3.6.2.1 for "not intrinsically safe" version

Measurement voltage 100, 115, 200, 230 and 500 + - 10 % VAC

Maximum current consumption $I_{\text{eff}}^* = 1.5 \text{ A}$

Max. peak current during a stroke $I_{\text{peak}} = 8 \text{ A}$

Maximum power consumption $P_{\text{wirk}}^* = 50 \text{ W}$

* obtained by averaging over several strokes at the maximum stroke rate

3.6.2.2 for the "intrinsically safe" version

Supply current circuit

Intrinsically safe rated voltage: 100, 115, 200, 230 + - 10%, 500 +6% -10% VAC

Maximum current consumption $I_{\text{eff}}^* = 1.5 \text{ A}$

Max. peak current during a stroke $I_{\text{peak}} = 8 \text{ A}$

Maximum power consumption $P_{\text{wirk}}^* = 50 \text{ W}$

* obtained by averaging over several strokes at the maximum stroke rate

3.6.3 Electrical data for the intrinsically safe (optional) diaphragm rupture indicator

Diaphragm rupture detector

Type Pepperl+Fuchs, NJ1,5-8GM-N-V1

Nominal voltage 8.2 V (Ri approx. 1 kOhm)

Normal power consumption ≤ 1mA

Power consumption in the event of a diaphragm rupture ≥ 3mA

Please observe the Operating Manual and the Type Examination Certificate of the diaphragm rupture sensor for detailed data and for use in areas at risk of explosion.

3.6.4 Electrical data, details

Pump type	1000, 2501, 1601, 1201, 0803, 1002, 0308					2502, 1006, 0613, 0417, 1002*****					2505, 1310, 0814, 0430, 0260				
Mains connection (V)	100	115	200	230	500	100	115	200	230	500	100	115	200	230	500
Max. current consumption*** (A)	1.6	1.4	0.7	0.8	0.3	3.0	2.7	1.8	1.8	0.6	4.1	3.6	2.2	2.5	1.1
Effective current consumption*** (A)	0.27	0.29	0.14	0.17	0.09	0.70	0.70	0.33	0.41	0.14	0.95	0.84	0.47	0.53	0.25
Mean power consumption (W)	16	16	16	16	16	35	35	35	35	35	47	47	47	47	47
Fuse item 65* value (A)/Type	1.0T	0.63T	0.4T	0.315T	0.319	2.5T	2.0T	1.25T	0.8T	0.63	3.15T	2.5T	1.6T	1.25T	1.25
Value (A)/Type	0.16T	0.16T	0.16T	0.16T	-	0.16T	0.16T	0.16T	0.16T	-	0.16T	0.16T	0.16T	0.16T	-

* special fuse with high switching capacity: only use original fuse

** use only original fuse

*** effective value during a stroke

**** obtained by averaging over several strokes at the maximum stroke rate

*****with material version PP4

Fuse order numbers, see chapter 11

NOTE

Only the effective power consumption is specified on the rating plate

3.7 Mechanical data, cables

Pump type	Voltage V	Cable	Cable type	Colour	outer Ø mm
EXBbG	to 250	power cable	H 07 RNF 3G1.5	black	10.0
EXBbG	> 250	power cable	NSSHÖU 3x1.5	yellow	12.5
EXBbM	all	power cable	NSSHÖU 3x1.5 +3x1.5/3E	yellow	14.0
EXBbG	< 60	external/analogue cable	Ölflex 110	grey	6.3
EXBbG	< 60	external/analogue cable	Ölflex EB	blue	5.9
EXBbM	< 60	external/analogue cable	L-YY (zg) Y	grey	11.4
EXBb_	8	diaphragm rupture detector		blue	

In "FM"- and "CSA" version H07 RNF up to 500 V, the cable aperture has a 1/2" NPT internal thread for connection to the North American supply system.

3.8 Ambient conditions

Admissible storage temperature -20 °C to +50 °C
 Admissible ambient temperature -20 °C to +45 °C
 Admissible chemical temperature -10 °C to +35 °C (in accordance with IEC 335-2-41)

Temperature resistance of material versions

	PP	NP	TT	SS
Long term at max. back pressure	50 °C	45 °C	50 °C	50 °C
Max. 15 min at max. 2 bar	100 °C	60 °C	120 °C	120 °C

Climate admissible humidity 92 % non condensing
 Behaviour in damp alternating climate DIN IEC 60068-2-78

Enclosure rating IP 65

Sound intensity level ≤ 70 dB (A), 1 m Abstand

4 Unpacking

NOTE

Polystyrene parts are recyclable. They do not belong in the household waste!

- ▶ It is advisable to keep the outside packing complete with the polystyrene parts in order to be able to return the metering pump in the case of repairs and warranty claims.
- ▶ Compare your delivery note with the packed contents.
- ▶ Check whether the data on the type identification plate (8) of the metering pump agree with your order data!
- ▶ Should any problems arise, contact your ProMinent dealer or representative. You will find the addresses on the back page of these operating instructions.
- ▶ Always specify the identity code and the serial number which you will find on the type identification plate when making any inquiries or ordering spare parts. In this way, the pump type and material variants can be clearly identified.

Scope of delivery

- Metering pump with power cable
- Operating instructions with conformity certificate
- Conformity declaration for Namur-Sensor (only with diaphragm rupture indicator)

5 Mounting and Installation



WARNING

- When installing the metering pump also observe the installation instructions for devices in explosive areas; for Europe the European operator directive 99/92/EC (ATEX137) and the ATEX Product Directive 94/9/EC (ATEX 95), implemented in Germany by the new health and safety legislation!
- When using the metering pump for metering flammable media, observe (in Europe) the European Operator Guideline 99/92/EC (ATEX 137, previously ATEX118a), implemented in Germany with the new operating safety directive and the German dangerous chemicals directive.
- Observe valid national regulations when installing the pump abroad!
- Remove all traces of water from the liquid end before starting operation with media which must not come in contact with water! The metering pump may still have water residue in the liquid end from the tests carried out at the factory.

5.1 Installing Metering Pump



IMPORTANT

- Secure the pump such that no vibrations can occur.
 - Ensure free access to facilitate operation and maintenance.
 - The valves of the liquid end must be in vertical position!
- ▶ The metering pump must be secured with screws and washers Ø 6 mm on a horizontal, firm base.

5.2 Installing Hose Lines



IMPORTANT

- Lay and secure intake and delivery lines such that they cannot chafe.
- Lay intake and delivery lines such that they are free of mechanical stress.
- Arrange all lines such that the pump and liquid end can be removed laterally if required.
- When metering extremely aggressive or hazardous media, a venting facility with return into the supply tank as well as a shut-off valve must be provided on the delivery and intake sides.
- Ensure all connections are tight:
only use the clamping rings and hose sockets as specified for the relevant hose diameter, only use original hoses with specified hose dimensions and wall thickness.
- Avoid reductions in hose sizes: use the next higher line cross-section for long hose lines and viscous media or install a compressed air vessel or diaphragm pulsation damper!

Fitting Hose lines

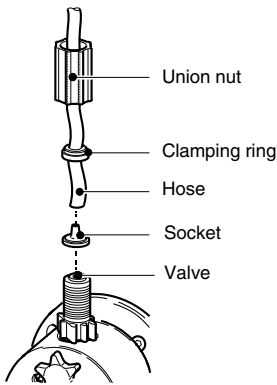

fig.: 3

- ▶ Remove plug if fitted in the intake/delivery connection.
- ▶ Cut end of hose straight.
- ▶ Fit union nut and clamping ring over hose.
- ▶ Fit end of hose as far as it will go over socket widen end if necessary.
- ▶ Fit hose with socket on to valve.
- ▶ Clamp hose connection:
Firmly tighten union nut while at the same time pressing down hose.
- ▶ Retighten hose connection:
Pull the hose line secured at the liquid end and then tighten the union nut once again.

Fitting stainless steel pipe connections

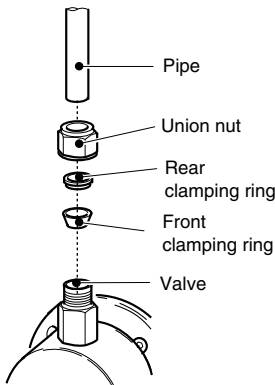

fig.: 4

- ▶ Fit union nut and clamping rings on to pipe with a projection of approx. 10 mm.
- ▶ Fit pipe as far as it will go into valve.
- ▶ Firmly tighten union nut.

Fitting PE or PTFE lines on stainless steel valves

- ▶ Additionally fit a stainless steel support sleeve in the plastic sleeve.

5.2.1 Installing the Intake Line

NOTE

- **The intake line should be as short as possible.**
- **Fit intake line in upright position in order to avoid air bubbles forming.**
- **Wherever possible use pipe bends and not elbows for bends in the intake line.**
- **Select cross section and length such that the vacuum which occurs during intake does not reach the vapour pressure of the medium to be metered. In extreme cases, excessively high vacuum on the intake side is reflected in collapse of the liquid column or by an incomplete return stroke.**
- **Do not exceed the permissible admission pressure on the intake side.**
- **Note: Suction lift x medium density \leq max. suction lift in m water column**
- **Refer to the installation examples.**

- Installing foot valve*
- ▶ Cut the free end of the intake line to size such that the foot valve just hangs over the bottom of the tank. In the case of metered solutions with impurities or bottom deposits, the foot valve should be located at an adequate distance above the tank bottom or bottom deposits.

5.2.2 Installing the Delivery Line



IMPORTANT

- **A multiple of the maximum operating pressure can build up if the metering pump is operated against a closed shut-off element on the delivery side. This can cause the delivery line to burst!**
An overflow valve should be installed in order to avoid this, e.g. a ProMinent multi-function valve.
- **Install the delivery line such that the pressure peaks during the metering stroke do not exceed the max. permissible operating pressure. Check length and cross-section. If necessary, install an overflow valve, compressed air vessel or diaphragm pulsation damper.**
- **Refer to installation examples!**

When metering with atmospheric discharge, a metering valve with 0.5 bar response pressure should be mounted at the end of the line. Or a back-pressure valve should be mounted directly onto the liquid end in order to create and maintain a counter-pressure of approx. 1.5 bar.

If the level of the fluid of the supply tank is above the pump in operating condition, the response pressure is on the suction end. In this case the counter-pressure should be sufficiently high such that a minimum differential pressure of 1.5 bar exists. If this is not the case a back-pressure valve or a spring-loaded metering valve with the respective response pressure should be used.

NOTE

A back-pressure valve or a spring-loaded metering valve is not an absolutely leakproof shut-off device!

On the suction end a stop valve is therefore to be installed which is closed when the metering pump is idle.









5.2.3 Installing the Bypass Vent Line (see fold-out page)

The liquid end of the pump types 1000 - 0417 NP and PP is equipped with a vent valve (5) with bypass (6).

The admission pressure on the intake side must be at least the same pressure as in the bypass line. Operation is not possible with admission pressure in the bypass and no pressure on the intake side

- ▶ Fit hose line with $\varnothing_{\text{internal}} = 4 \text{ mm}$ (max. 6 mm) on to bypass hose socket, PVC-soft 6x4 is recommended.
- ▶ For PE lines, secure against slipping using a quick fastener.
- ▶ Route the free end of the line back into the metering tank.
- ▶ Cut the bypass line to size such that it is not submerged in the metering medium.

5.3 Installation Examples, Mechanical/Hydraulic

<p>Symbols</p>  Oscillating diaphragm metering pump  Foot valve  Shut-off valve  Pressure gauge  Solenoid Valve (closed when pump switched off)	 Injection valve  Pressure retention valve/ overflow valve  Pressure retention valve (adjustable)  Compressed air vessel
---	--

Standard installation

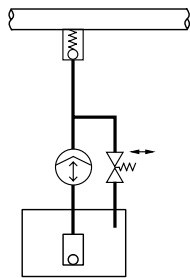

Metering with free outlet and small delivery head

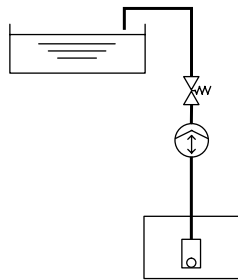

.... and large delivery head

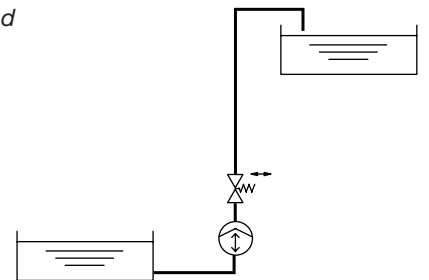

... and admission pressure on intake side

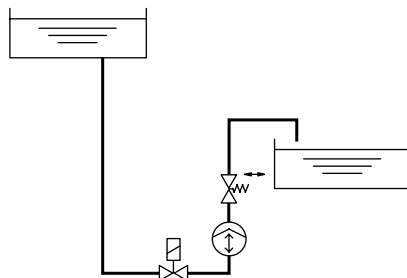

Installation to avoid lift-through of hazardous media

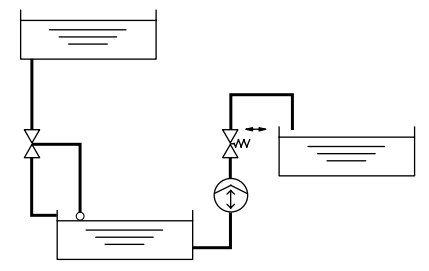
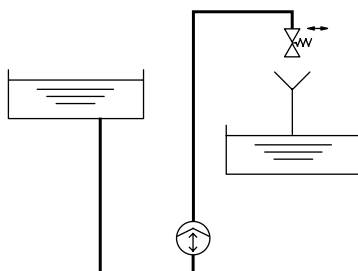

Mounting and Installation

Installation together with air vessel with long lines and for low-pulsation metering

... in a delivery line

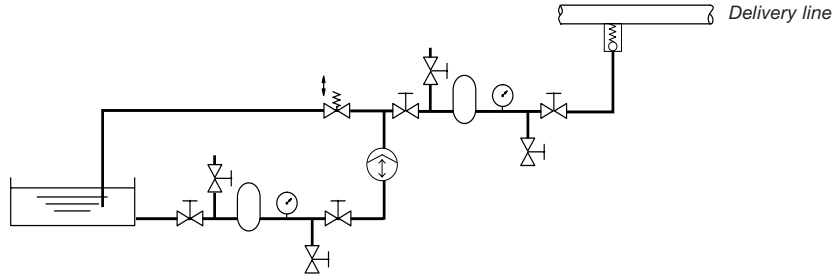

... with free outlet

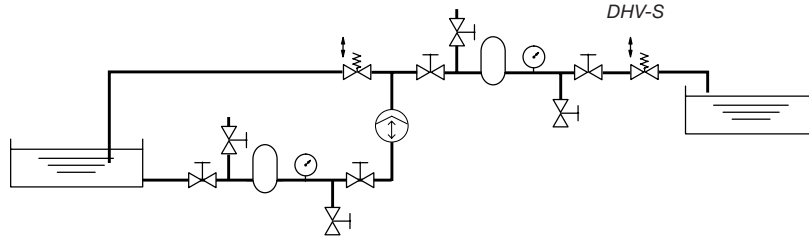

... without after-running

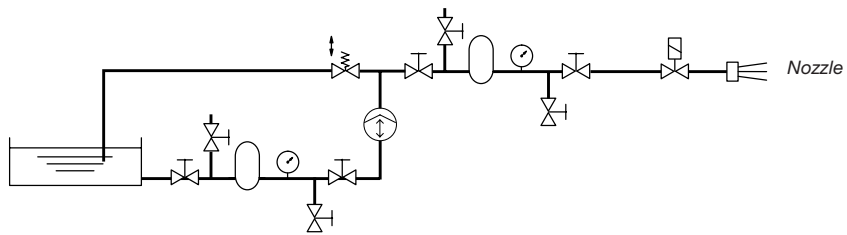

To protect against overpressure

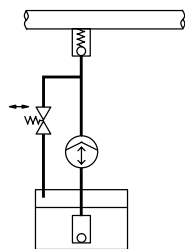

Metering in vacuum or intake line

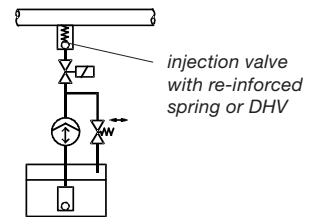

Do not install like this:
Intake line cannot be vented!

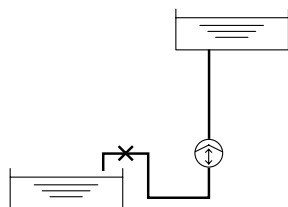

Do not install like this:
Intake line too high!

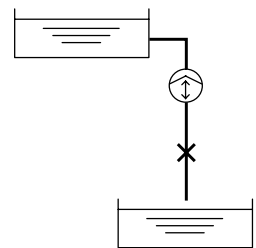

Do not install like this:
Free flow!

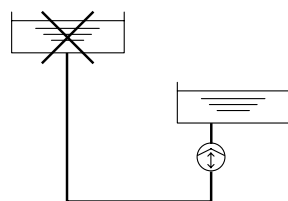

Do not install like this:
Compressed air vessel not effective!

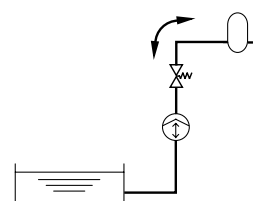

5.4 Electrical Installation



IMPORTANT

- The metering pump must be electrically installed by authorised, “skilled” personnel only.
- When installing the metering pump also observe the installation instructions for devices in explosive areas; for Europe the European operator directive 99/92/EC (ATEX137) and the ATEX Product Directive 94/9/EC (ATEX 95), implemented in Germany by the new health and safety legislation!
- Observe the relevant standards e.g. DIN EN 60079, DIN EN 60079-11, DIN VDE and/or 0118 “Erecting electrical equipment in explosion-threatened areas” DIN EN 60079-14!
- Note all national directives which apply to the installation when installing outside Germany.
- Intrinsically safe installations must be checked by persons with “recognised qualifications“.
- Do not connect mains power supply to the external terminal (11).
- The internally used fusible link has a breaking capacity of 1,500A. If the short-circuit current in the supply network may be larger than 1,500A, the pump is to be protected with a suitable back-up fuse with a higher breaking capacity (rated current smaller than 1,500A).

Power connection

Electrical data see 3.6

The connection terminal (23) for the equipotential bonding conductor is located on the housing next to the power supply terminal (12).

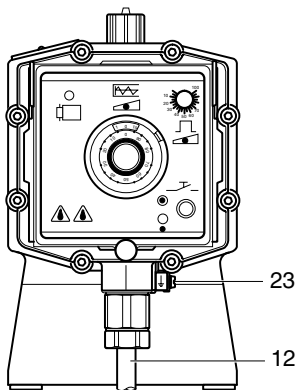

fig.: 5

- 12 Power supply
- 23 Connection terminal for equipotential bonding

EXBbG L1: Phase, brown
 N: Zero wire, blue
 PE: Earth lead, yellow/green

EXBbM L1: Phase, brown
 N: Zero wire, blue
 -: free, black*
 PE: Earth lead, yellow/green**

* Internally insulated, connect to a free terminal on the outside.

** Twist the three single coaxial earth leads together, fit yellow/green sleeve and attach to the earth lead terminal.

Induction voltage

If the pump is connected to the power supply parallel to inductive loads (e.g. solenoid valve, motor), it must be electrically isolated from these loads in order to avoid damage caused by induction voltages when switching off.

- ▶ Use several contacts for power supply via auxiliary contactor or relay.
- ▶ In the 100-V- to 230-V-versions, connect a varistor ($U_N = 275\text{ V}$) or RC-element (0,22 $\mu\text{F}/220\text{ Ohm}$) in parallel.



Abb.: 6

Switching on

With power switch (13), a power switch must be provided by the customer for the 500 V version.

External, contact, analogue and pause input, not intrinsically safe

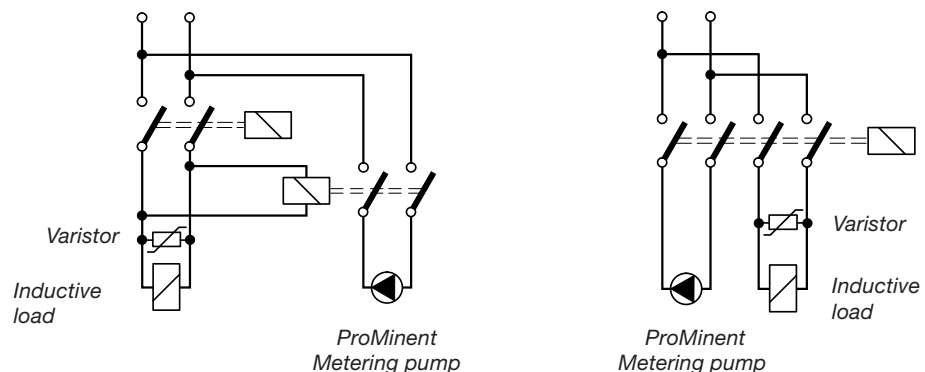
EXBbG input+ black (1)
Input- black (2)

EXBbM input+ blue
Input- black

External, contact, analogue and pause input intrinsically safe, sheath colour blue.

EXBbG und EXBbM: Input (+) = brown (1)
Input (+) = blue (2)

El. terminal for diaphragm rupture detector, intrinsically safe, sheath colour blue.

ExBbG and EXBbM: Alarm, blue
GND+, brown

6 Operation

6.1 Start-Up



WARNING

- Always wear protective goggles and protective clothing when handling hazardous media!
- The metering pump may still contain water residue in the liquid end from the tests carried out at the factory. All water must be removed from the liquid end before start-up in the case of media which must not come in contact with water!

NOTE

- Carry out all settings only with the pump in operation. Release the lock before adjusting the stroke length!
- The intake head with the liquid end empty is dependent on the stroke volume: The pump intake should be set at stroke length = 100 %. Select the intake head correspondingly smaller if the pump is to be discharged at a lower setting without changing the stroke length and is to be placed into operation again self-priming.
- Pump intake is not possible against backpressure
- Absolutely reliable metering cannot be guaranteed after a pump down period. Regular monitoring is necessary!

Before start-up

- ▶ Check function of pressure relief valves.
- ▶ Check pump connections and pipe connections for leaks.

Remove water from liquid end

when handling media which must not come in contact with water:

- ▶ Turn pump through 180°.
- ▶ Empty liquid end.
- ▶ Flush with a suitable medium from above through the intake connection.

Filling liquid end

without vent valve:

- ▶ Connect intake line but do not yet connect the delivery line to the liquid end.
- ▶ Switch on pump with power switch (13) and operate at max. stroke length and stroke rate until liquid end is filled completely and free of bubbles.
- ▶ Switch off pump with power switch (13).
- ▶ Connect delivery line to liquid end.

The pump is now ready for operation.

*Filling liquid end
Rough venting*

liquid end with vent valve and bypass:

- ▶ Connect intake and delivery line to liquid end.
 - ▶ Connect bypass line.
 - ▶ Open vent valve (5) by one turn of the star knob in counterclockwise direction; the routes for rough venting via the bypass (6) is now clear.
 - ▶ Switch on pump with power switch (13) and operate at max. stroke length and stroke rate until liquid end is filled completely and free of bubbles (when the medium is visible in the venting or metering line).
 - ▶ Close vent valve.
 - ▶ Switch off pump with power switch (13).
- The pump is now ready for operation

Setting fine vent

metering gas-emitting media:

NOTE

- **A part of the metered quantity is constantly routed back into the supply tank. The return quantity should be approx. 20 % of the metered quantity.**
 - **The media must be low-viscous (thin-bodied) and without solids.**
 - **If the return flow line ends above the liquid level, the precision vent valve acts as a vacuum breaker and prevents discharge of the supply tank if a vacuum builds up in the metering line.**
 - **Retighten the screws in the liquid end after 24 hours of operation.**
- ▶ Remove star knob from vent valve (5).
 - ▶ Using a screwdriver, turn screw in vent valve approx. 1 turn in counterclockwise direction.
 - ▶ Fit star knob on vent valve (5).

Venting liquid end

HV version:

Initial intake and venting is impaired to a certain extent by the valves and valve springs which are still dry. Therefore select the shortest possible intake head or vent the liquid end with inlet or admission pressure on the intake side.

If not successful, shortly operate pump without valve spring in the pressure valve:

- ▶ Unscrew delivery connection and press away ball from O-ring.
- ▶ Fill liquid end with water or suitable liquid.
- ▶ Fit delivery connection without valve spring.
- ▶ Fit short piece of PVC hose (100 mm) on to hose socket, half fill with water.
- ▶ Operate pump at max. stroke length until metering is visible in the hose.
- ▶ Re-install valve spring – avoid twisting by fitting an approx. 4 mm Ø drift through the pressure valve in order to hold the spring in the centre position.
- ▶ Reconnect delivery line.

Venting liquid end

when pump delivers in a pressure system and has drawn in air:

- ▶ Set venting on delivery side: Release metering line or open vent valve.
- ▶ Switch on pump and vent at stroke length 100 %.

6.2 Determining the Delivery Capacity

The actual delivery capacity is dependent on the stroke length, stroke frequency (rate) and backpressure in the metering line. The relationship between capacity/stroke length/stroke frequency (rate) is illustrated in the nomogram for each type of pump. A correction factor can be read off from the diagram which shows the change in capacity referred to backpressure.

The measurements for determining the nomograms were conducted with water and the correction factor was determined at a stroke length of 70 %. The capacity scatter over all material versions is -5 % (for max. value: not specified).

- ▶ Select the required capacity within the value range of the pump type (see capacity data).
- ▶ Select the nomogram and diagram of the pump type.
- ▶ Mark the backpressure in the metering system on the abscissa and read off the corresponding correction factor on the ordinate.
- ▶ Divide the required capacity by the correction factor.
- ▶ Using a ruler, mark the determined capacity on the middle scale of the nomogram.
- ▶ Draw a line across all three scales – as horizontal as possible, however, such that the line intersects at least one of the two outer scales; where possible, select a graduation with a large value on the stroke length scale.

The point of intersection of the line with the right-hand scale shows the stroke frequency (rate) to be set, the point of intersection of the line with the left-hand scale shows the stroke length to be set.

Capacity with mean backpressure:	11.9 l/h (see capacity data)
Required capacity:	6 l/h
Backpressure:	8 bar
→ Correction factor as per diagram:	0.9
→ Capacity to be set:	$\frac{6 \text{ l/h}}{0.9} = 6,66 \text{ l/h}$
→ Stroke length as per nomogram:	80 %
→ Stroke rate as per nomogram:	80 stroke/min

NOTE

- **Select large stroke length and low stroke rate for highly viscous and gas-emitting media.**
- **Use self-venting liquid end for gas-emitting media with viscosity $\leq 20 \text{ mPa s}$.**
- **Select a shorter stroke length and high stroke rate for effective mixing.**
- **For a precise dosing, choose metering-stroke of not less than 30 %.**
At max. pressure stroke length
 - ≥ 60 % for type 1601,
 - ≥ 40 % for type 1201 and 1002,
 - ≥ 20 % for type 0803;**the stroke length can be reduced further at lower pressure.**
- **Set the stroke length greater for pumps with the precision vent open**

6.3 Nomograms

EXBb_1000

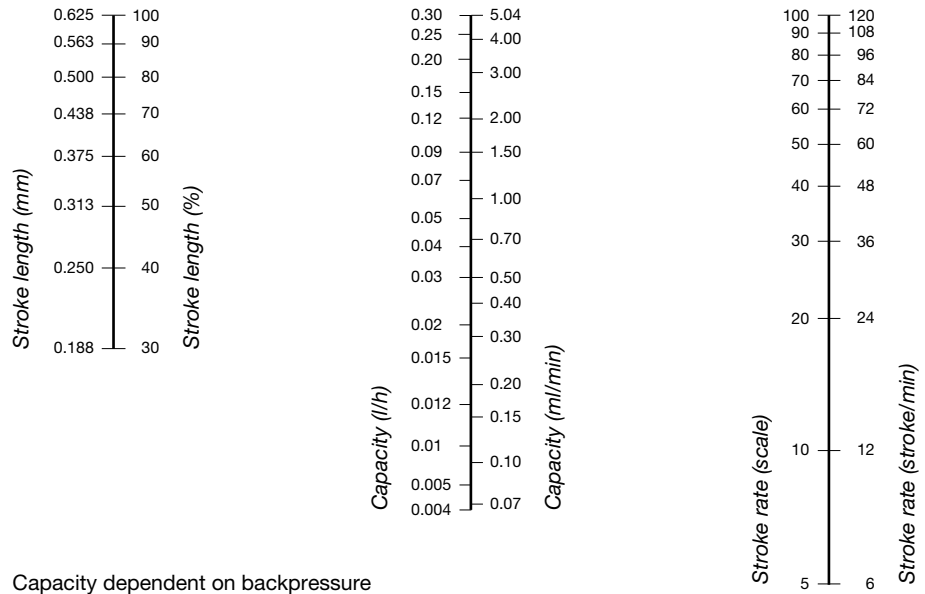

Capacity dependent on backpressure

Capacity 0.27 l/h at medium backpressure of 5 bar
 Capacity 0.19 l/h at max. backpressure of 10 bar

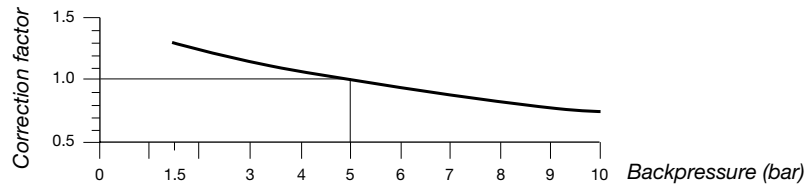

EXBb_2501

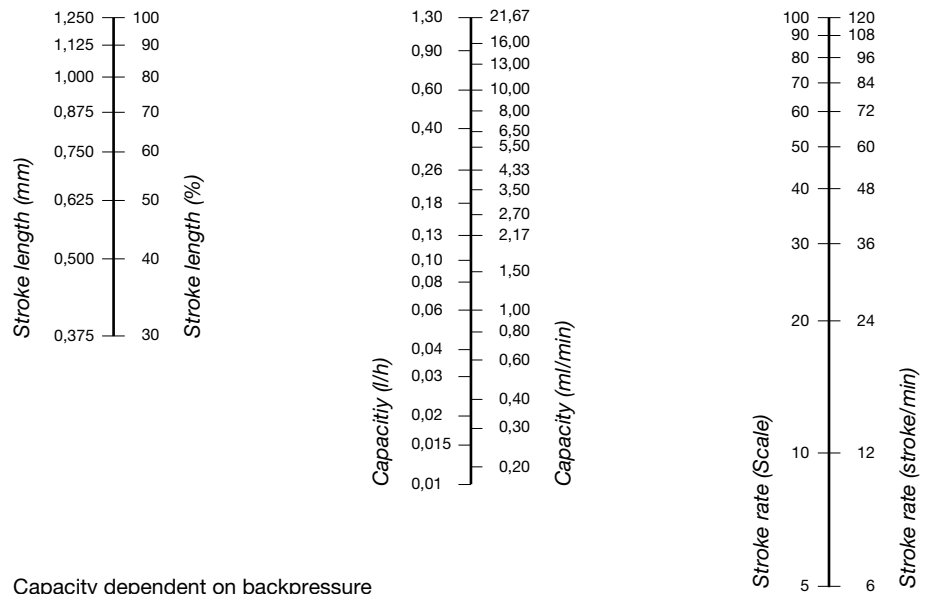

Capacity dependent on backpressure

Capacity 1,30 l/h at medium backpressure of 16 bar
 Capacity 1,10 l/h at max. backpressure of 25 bar

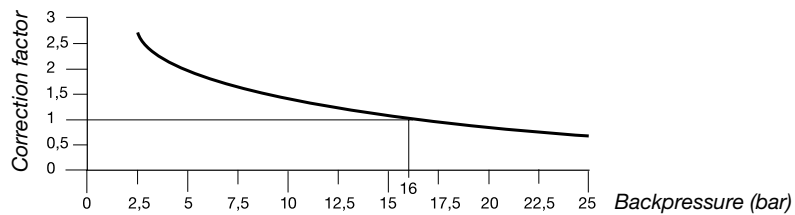

EXBb_1601

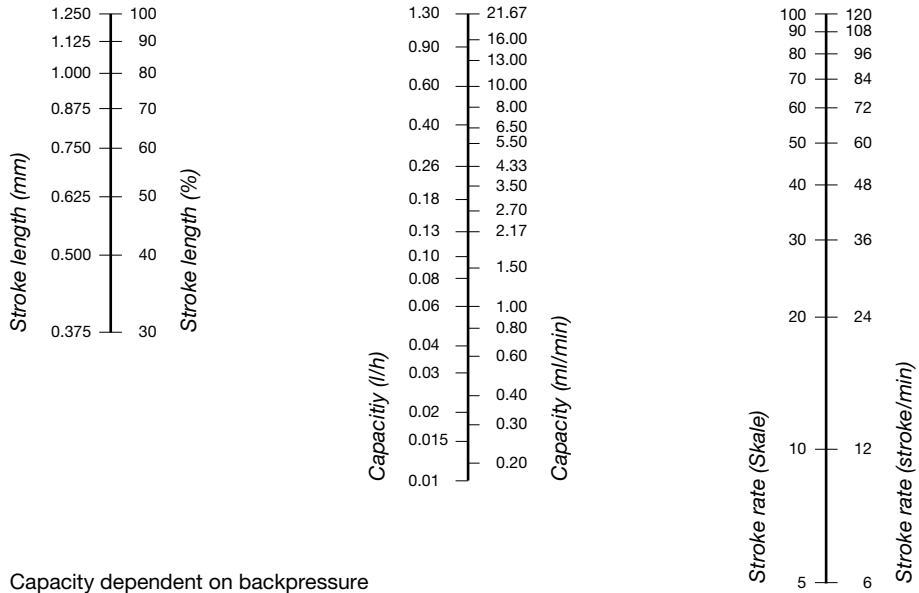

Capacity dependent on backpressure

Capacity 1.30 l/h at medium backpressure of 8 bar
 Capacity 1.00 l/h at max. backpressure of 16 bar

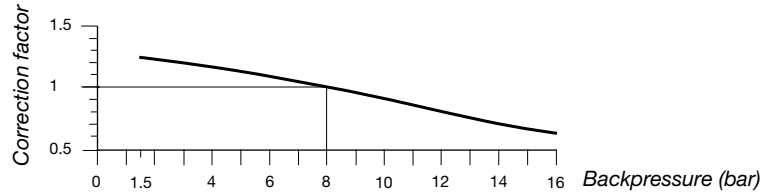

EXBb_1201

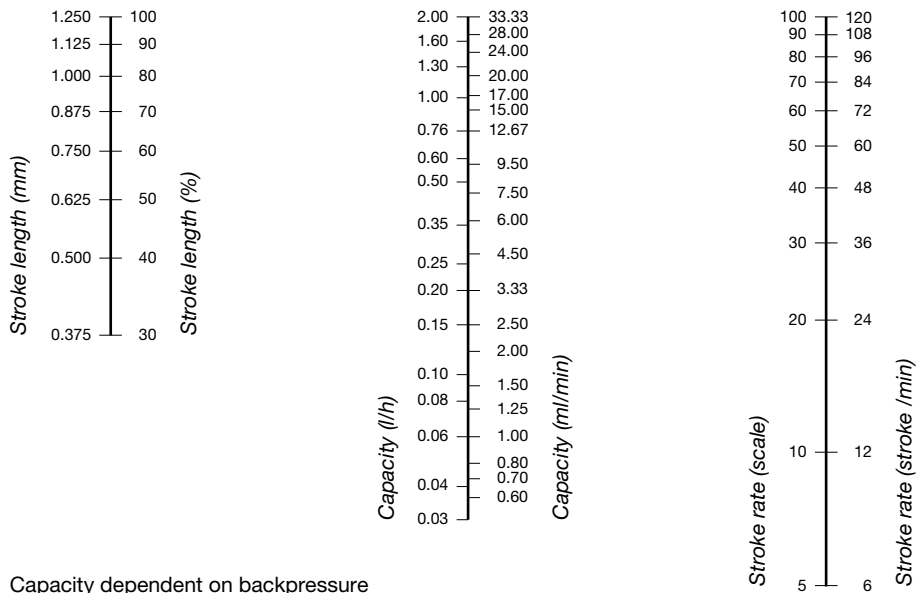

Capacity dependent on backpressure

Capacity 2.00 l/h at medium backpressure of 6 bar
 Capacity 1.70 l/h at max. backpressure of 12 bar

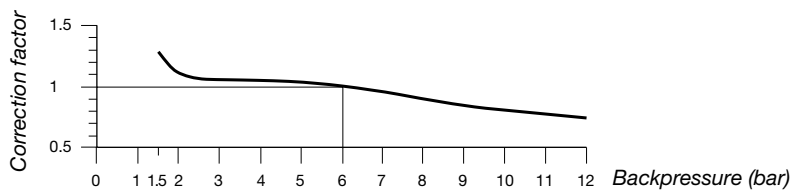

EXBb_0803

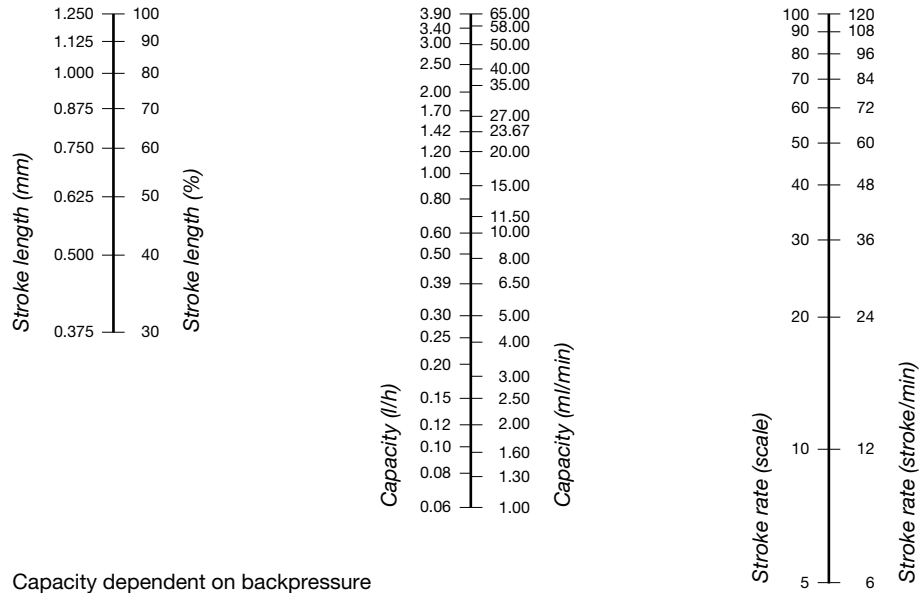

Capacity dependent on backpressure

Capacity 3.90 l/h at medium backpressure of 4 bar
 Capacity 3.70 l/h at max. backpressure of 8 bar

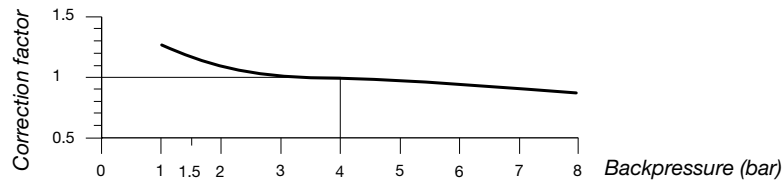

EXBb_1002

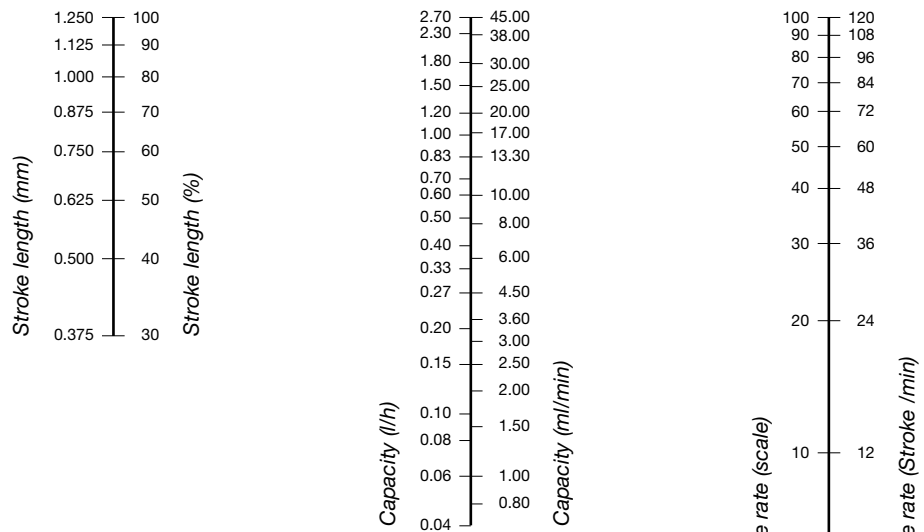

Capacity dependent on backpressure

Capacity 2.70 l/h at medium backpressure of 5 bar
 Capacity 2.30 l/h at max. backpressure of 10 bar

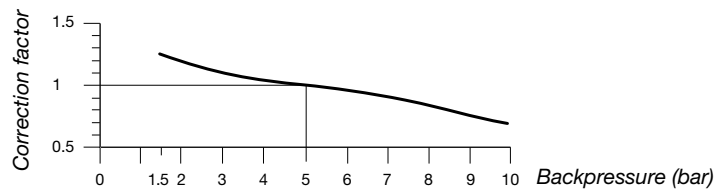

EXBb_0308

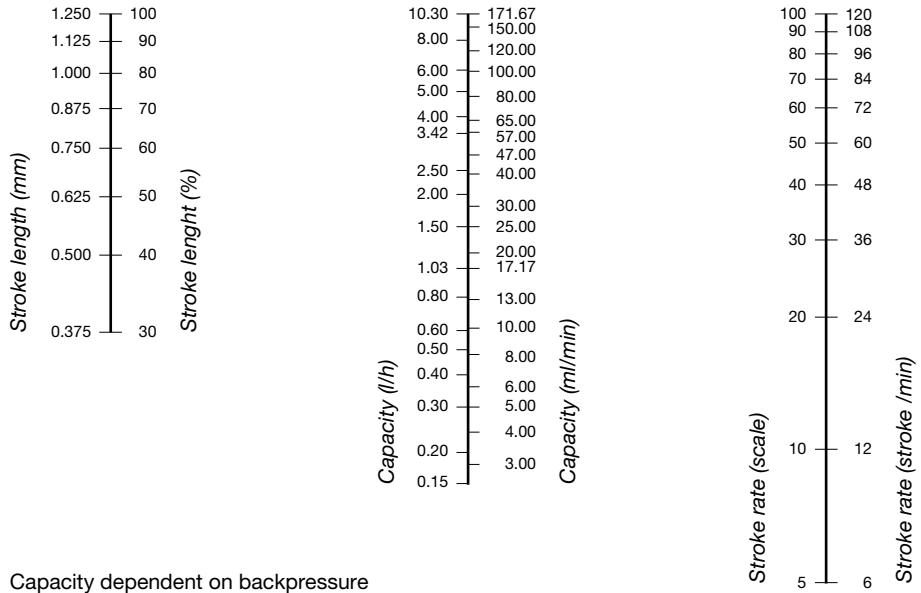

Capacity dependent on backpressure

Capacity 10.30 l/h at medium backpressure of 1.5 bar
 Capacity 8.70 l/h at max. backpressure of 3 bar

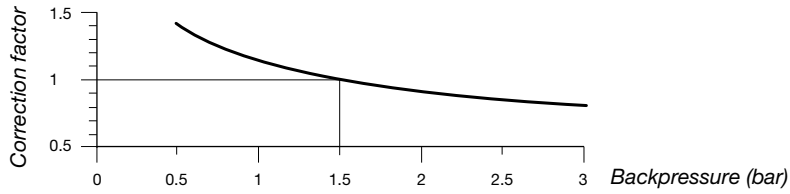

EXBb_2502

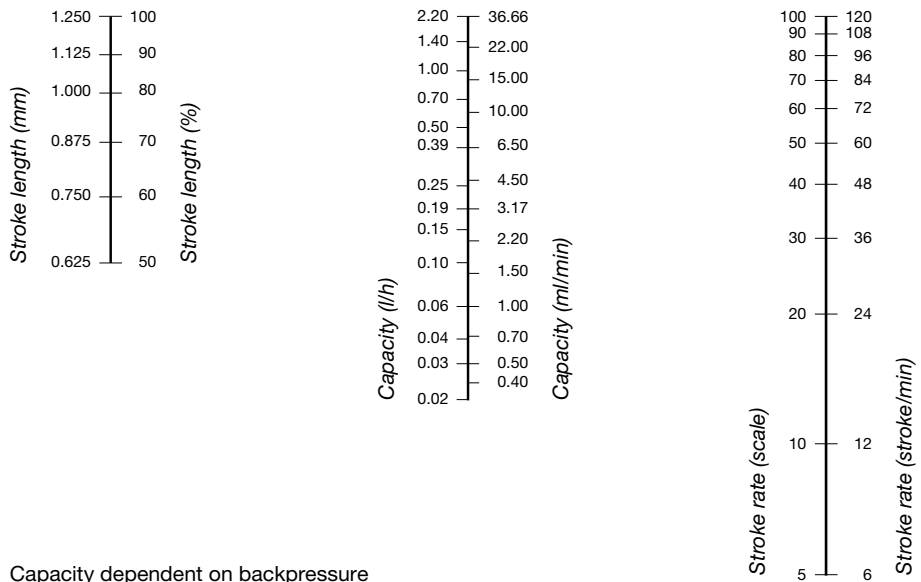

Capacity dependent on backpressure

Capacity 2.20 l/h at medium backpressure of 20 bar
 Capacity 2.00 l/h at max. backpressure of 25 bar

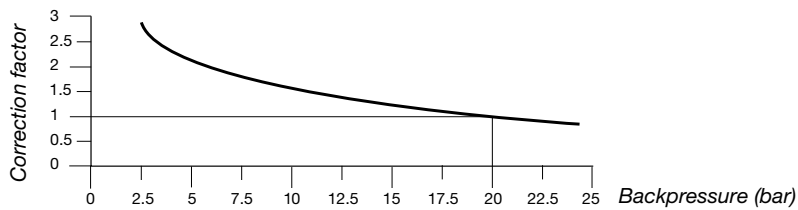

EXBb_2505

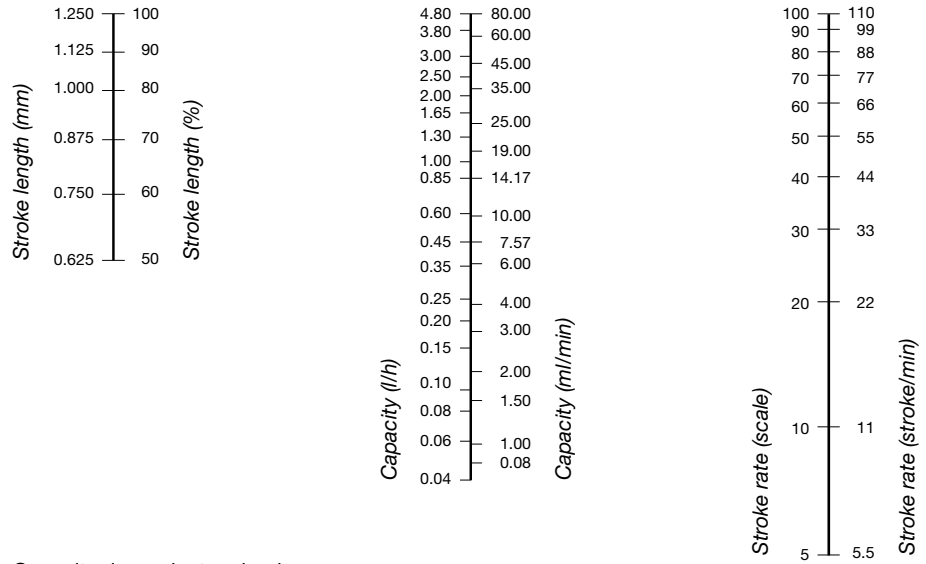

Capacity dependent on backpressure

Capacity 4.80 l/h at medium backpressure of 20 bar
Capacity 4.20 l/h at max. backpressure of 25 bar

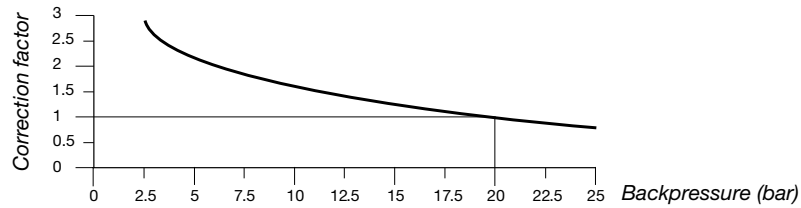

EXBb_1006

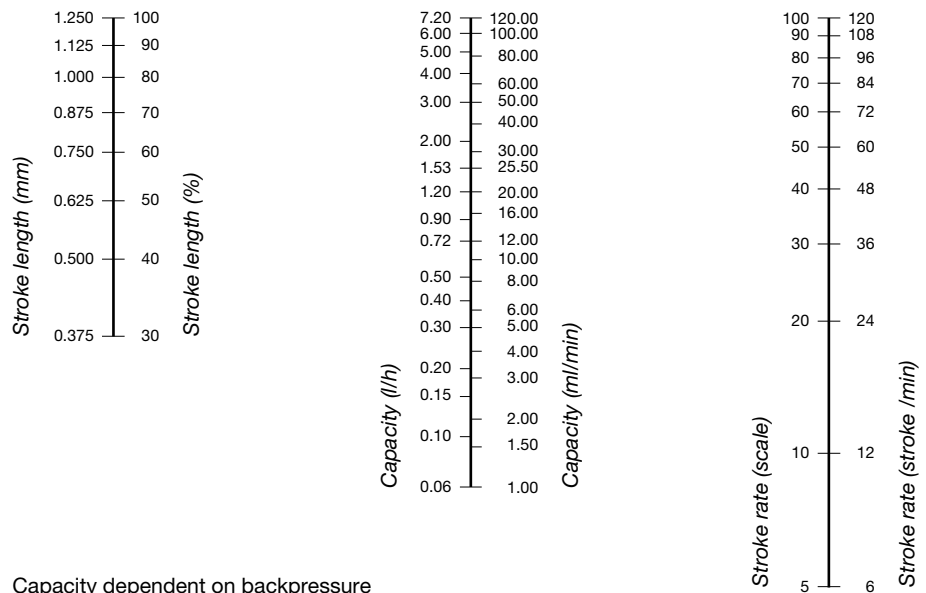

Capacity dependent on backpressure

Capacity 7.20 l/h at medium backpressure of 5 bar
Capacity 6.00 l/h at max. backpressure of 10 bar

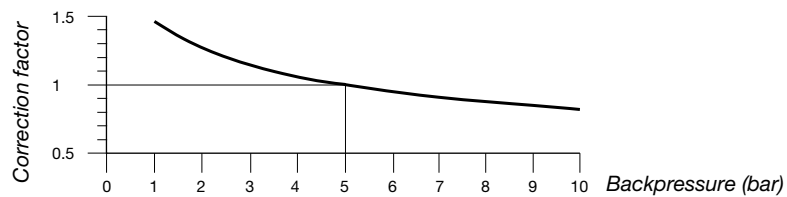

EXBb_1310

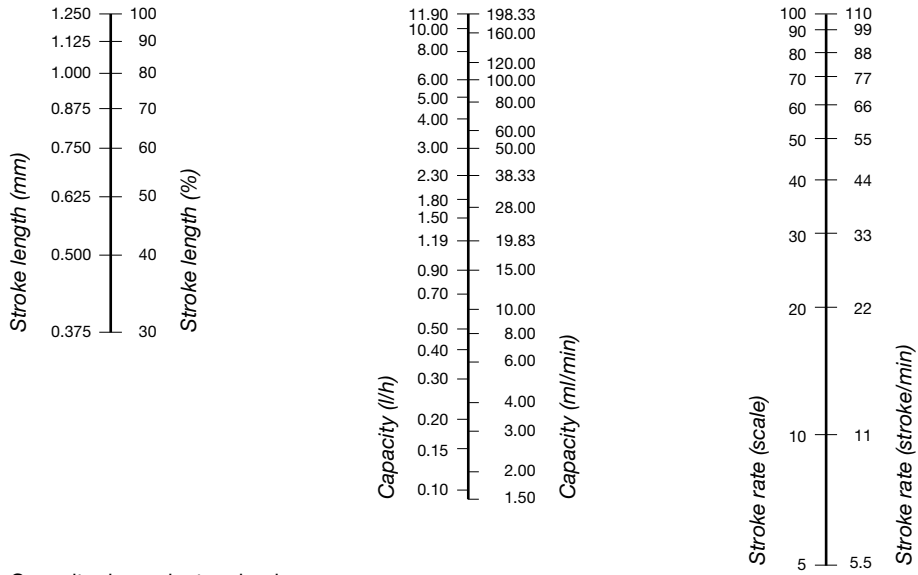

Capacity dependent on backpressure

Capacity 11.90 l/h at medium backpressure of 6 bar
 Capacity 10.50 l/h at max. backpressure of 13 bar

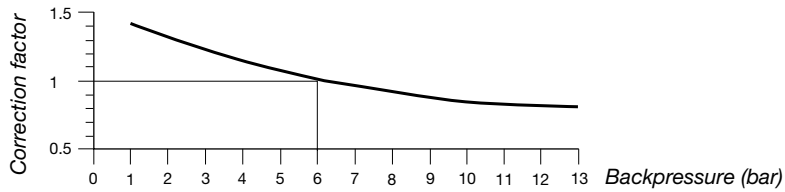

EXBb_0613

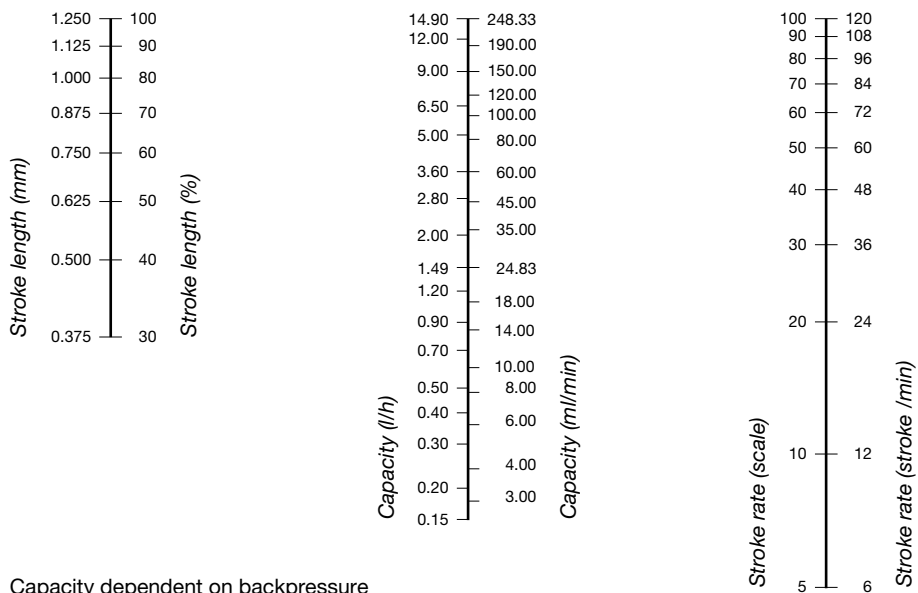

Capacity dependent on backpressure

Capacity 14.90 l/h at medium backpressure of 3 bar
 Capacity 13.10 l/h at medium backpressure of 6 bar

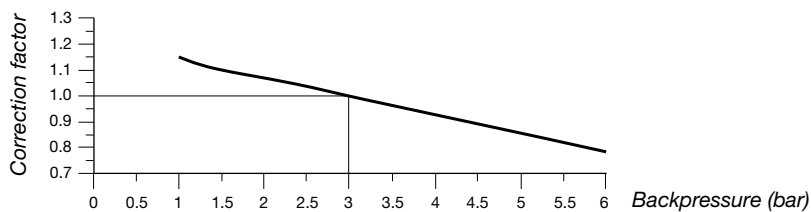

EXBb_0814

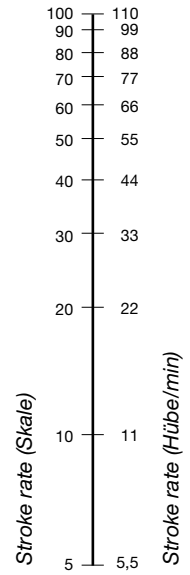
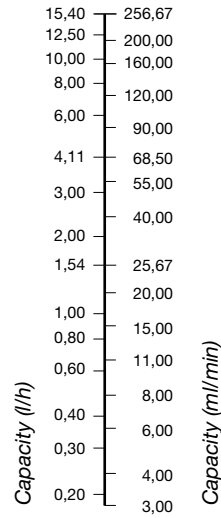
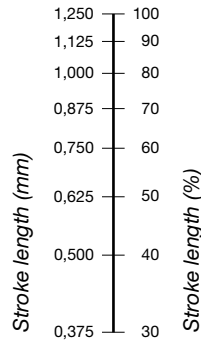

Capacity dependent on backpressure

Capacity 15,40 l/h at medium backpressure of 5 bar
 Capacity 14,00 l/h at max. backpressure of 8 bar

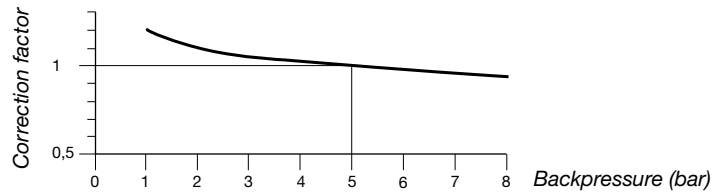

EXBb_0417

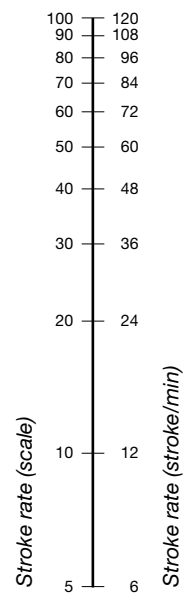
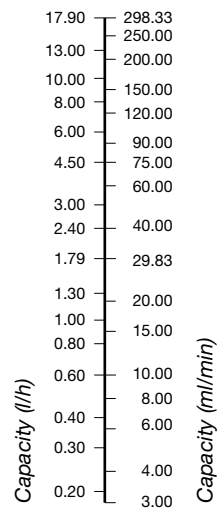
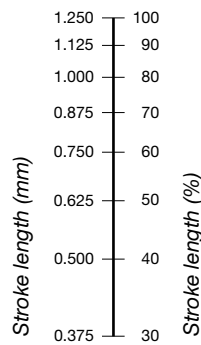

Capacity dependent on backpressure

Capacity 17,90 l/h at medium Backpressure of 2 bar
 Capacity 17,40 l/h at medium Backpressure of 3,5 bar

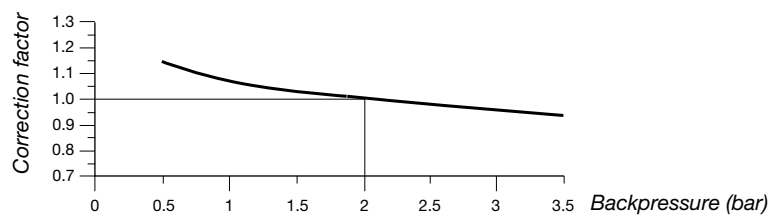

EXBb_0430

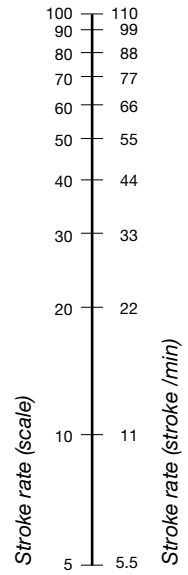
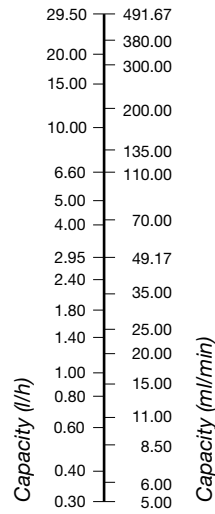
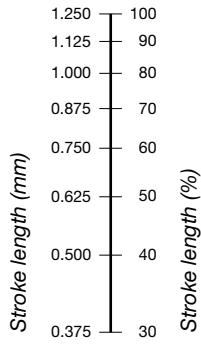

Capacity dependent on backpressure

Capacity 29.50 l/h at medium backpressure of 2 bar
 Capacity 27.00 l/h at max. backpressure of 3.5 bar

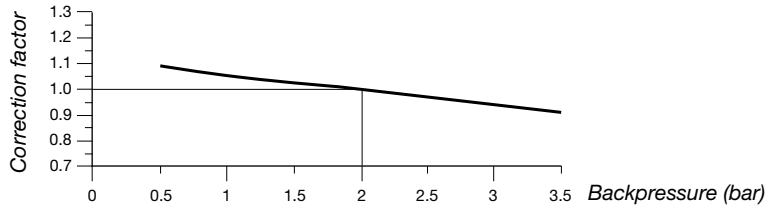

EXBb_0260

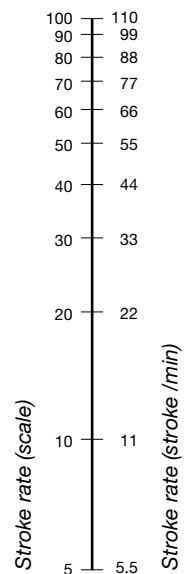
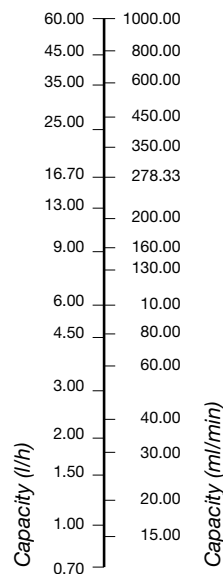
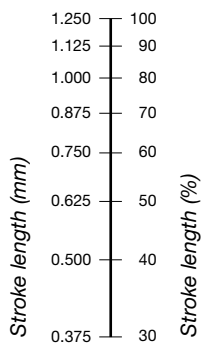

Capacity 60.00 l/h at max. backpressure of 1.5 bar

6.4 Setting the Delivery Capacity

NOTE



Adjust the stroke length only with the pump running!

The adjustment of the stroke length control knob will be varied if the stroke length control knob (14) is turned without previously releasing the lock (15).

Defective metering is possible if the notes on setting are disregarded.

Installation and commissioning of the pump are concluded.

The setting values have been determined by means of nomograms.

- | | |
|--|---|
| Switching on
 | <ul style="list-style-type: none"> ▶ Open transparent cover (17). ▶ Switch on pump with power switch (13). |
| Setting stroke length
 | <ul style="list-style-type: none"> ▶ Release the lock before setting the stroke length: Press up the locking lever (15). ▶ Adjust determined stroke length with the control knob (14) the ring scale on the control knob (14) has a graduation of 0.01 mm, the stroke length is indicated in mm in the inspection window (10). The total setting range for the stroke length is 0 to 1.25 mm (0.63 mm for pump type 1000), i.e. only the settings 0 and 1 are possible in the inspection window (10). ▶ Lock stroke length control knob (14): Press down locking lever (15). |
| Setting stroke rate
 | <ul style="list-style-type: none"> ▶ Adjust determined stroke rate with the control knob (16); on graduation line corresponds to 1 stroke/min. |
| Correction for accurate metering | <ul style="list-style-type: none"> ▶ Determine delivery capacity on the intake side of the metering pump with a measuring cylinder or by weighing. ▶ Correct pump setting. |

7 Maintenance



IMPORTANT

Only authorized persons are permitted to carry out maintenance on EXtronic®-metering pumps.



IMPORTANT

Always wear protective goggles and protective clothing when handling hazardous media!

- | | |
|------------------|--|
| Maintenance jobs | <ul style="list-style-type: none"> • Check firm fit of liquid end screws; retighten screws in liquid end after 24 hours of operation. • Check firm fit of metering lines. • Check firm fit of pressure valve and intake valve. • Check entire delivery unit for leaks. • Check correct pump delivery capacity: Briefly operate pump in intake mode. |
|------------------|--|

For self-venting liquid end:

- Check firm fit of bypass line and of connection.
- Replace fuses and electronic control.
- Check vent function.

- | | |
|-----------------------|---|
| Maintenance intervals | Every 3 months
Shorter intervals for operation under heavy load (e.g. permanent operation) |
|-----------------------|---|



IMPORTANT

The safety diaphragm is a consumable and must be replaced after the rupture of the second working diaphragm or after 10 000 pump service hours.

The separating diaphragm of the diaphragm rupture detector should be replaced after every working diaphragm rupture.

A visual inspection of the condition of the safety diaphragm should be carried out each time the working diaphragm is replaced.

8 Repairs



IMPORTANT

- Use only genuine spare parts.
- Always wear protective goggles and protective clothing when handling hazardous media.



WARNING

The following repair measures on EXtronic®-metering pumps must only be carried out by specially trained persons or by the manufacturer:

- Replace ex-relevant parts.
- Replace damaged power connection cable.
- Replace fuses and electronic control.
- Repairs on metering pumps for combustible media, also in the area of the liquid end.

Conversion to different capacities, material or type of control are only possible at the manufacturer's factory. Please contact your ProMinent dealer or representative. You will find the addresses on the back page of these operating instructions.

Send back the metering pump for repair only in a clean condition and with the liquid end flushed clean!



WARNING

- Pumps used with radioactive media must not be sent!
- Only return metering pumps for repair in a cleaned state and with a flushed liquid end! Only send metering pumps with a filled in decontamination declaration form. The decontamination declaration forms part of an inspection / repair order. An inspection or repair can only be implemented if a decontamination declaration form has been completed correctly and in full by an authorised and qualified person on behalf of the pump operator. The "Decontamination Declaration Form" can be found in the Appendix or at www.prominent.com.

8.1 Replacing working diaphragm / safety diaphragm



WARNING

Rinse the liquid end first if using hazardous metering chemicals. Use water or a suitable rinsing solution in a squeeze bottle and inject it into the suction connector of the liquid end. Protect yourself from unknown or hazardous metering chemicals.

After a diaphragm rupture, there will be chemical in the diaphragm rupture detector and the intake channel in the spacer plate (5).

- Set stroke length to zero when the pump is running. Switch off pump.
- Slacken liquid end screws and remove liquid end fastening screws
- Then slacken and unscrew the working diaphragm (6) (see Fig. 1) by twisting the adapter (2) to the left with both hands.
- Remove the spacer plate (5) and check the condition of the safety diaphragm (4)
- If the safety diaphragm is ruptured, replace it with a new one (see also 8.2).

- Place the spacer plate (5) on the top plate
- Tighten new working diaphragm (6) with both hands until hand-tight.
- Further assembly instructions, see 8.2

8.2 Servicing diaphragm rupture detector



WARNING

- **Disconnect the diaphragm rupture indicator from the monitor!**
- **Protect yourself from unknown or hazardous metering chemicals.**
- **After a diaphragm rupture there will be chemical in the diaphragm rupture detector and the intake channel in the spacer plate (5).**
- **Check the diaphragm rupture detector after every diaphragm rupture and replace the separating diaphragm if necessary (e.g. if the chemical is crystallising or is carrying dirt and particles).**

NOTE

- **When screwing the diaphragm rupture indicator in or out, ensure that the cable does not become too twisted.**
- **Connect the monitor to check for electrical continuity.**

8.3 Checking the diaphragm rupture sensor

NOTE

- **When screwing the diaphragm rupture indicator in or out, ensure that the cable does not become too twisted.**
- **Connect the monitor to check for electrical continuity.**
 - ▶ When changing the diaphragm, unscrew the diaphragm rupture sensor from the dosing head.
 - ▶ Check that the monitor does not indicate a diaphragm rupture:
 - ▶ Using a blunt insulating probe (Ø 2 ... 3 mm, no sharp edges), press into the channel of the diaphragm rupture sensor.
 - ▶ The monitor must indicate a diaphragm rupture.
 - ▶ Release the pin again.
 - ▶ The monitor must no longer indicate a diaphragm rupture.
 - ▶ Repeat the test several times.
 - ▶ If everything is working correctly, screw the diaphragm rupture sensor into the dosing head with a new seal (1).
 - ▶ If not, go to the next section.

8.4 Replacing the separating diaphragm of the diaphragm rupture sensor

- ▶ Disconnect the diaphragm rupture sensor from the monitor.
- ▶ When changing the diaphragm, unscrew the diaphragm rupture sensor from the dosing head.
- ▶ Grasp the top part (2) of the diaphragm rupture sensor.

NOTE

- **Do not tamper with the lacquer-protected nut.**
 - ▶ Hold the body (5) in place with an open-ended spanner.
 - ▶ Unscrew the diaphragm rupture sensor.
 - ▶ Clean the soiled parts.
 - ▶ Lay the new separating diaphragm (3) with the light side (PTFE) down in the top part (2).
 - ▶ Place the disc (4) in the top part (2).
 - ▶ Place the spring inside the body (5).
 - ▶ Move the body (5) close to the top part (2).
 - ▶ The spring (6) must sit correctly on the spring seat (3a).
 - ▶ Screw the body (5) in the top part and screw tight.
 - ▶ Re-connect the diaphragm rupture sensor to the monitor.
 - ▶ Check the diaphragm rupture sensor as described under “Check diaphragm rupture sensor”.
 - ▶ If the diaphragm rupture sensor does not operate clearly and reliably, then a new diaphragm rupture sensor must be used without fail.

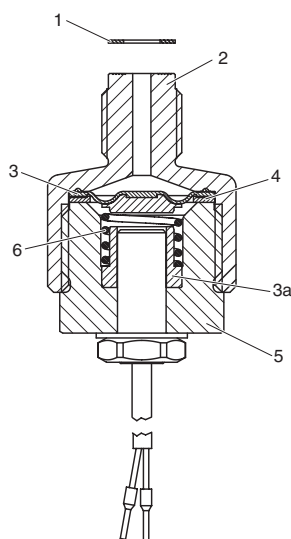

fig.: 7

9 Malfunctions



IMPORTANT

- Always wear protective goggles and protective clothing when handling hazardous media.
- Observe the safety data sheets of the metering liquids.
- Discharge liquid end and, if necessary, flush with a neutral agent.
- First decompressurize the metering line before carrying out any work on the pump.

9.1 Operation/pulse indicator does not light, no stroke movement

Cause **Incorrect or no mains voltage available**

Remedy ▶ Apply the mains voltage as specified on the nameplate.

Cause **Fuse is defective**

Remedy ▶ Contact your ProMinent dealer or representative.
You will find the addresses on the back page of these operating instructions.

9.2 Pump intake no longer operable despite full stroke movement and venting

Cause **Crystalline deposits on ball seat caused by valves drying out**

Remedy ▶ Remove intake hose from metering tank.
▶ Open vent valve.
▶ Flush liquid end well through.
▶ If not successful, remove and clean valves.

9.3 Pump no longer meters, although operation/pulse indicator lights

Possible Cause **Medium level in tank too low.**

Remedy ▶ Top up

Possible Cause **Stroke length set too small**

Remedy ▶ Increase stroke length with control knob (14)

Possible Cause **Air trapped in liquid end**

Remedy Liquid end without vent ▶ Set venting on delivery side via overflow or pressure relief valve or release metering line at injection valve or pressure connection.

▶ Switch on pump and vent at stroke length of 100 %

Remedy Liquid end with vent ▶ Open vent valve (5) by max. 1 turn in counterclockwise direction.

▶ Pump intake until intake line and liquid end are filled free of bubbles.

▶ Close vent valve (5).

9.4 Liquid Emerges from end ring

Possible Cause **Delivery unit leaking at diaphragm**

Remedy ▶ Retighten screws (24) crosswise in liquid end.



IMPORTANT

Observe tightening torques:

For M4 screw M4 → 2.5–3 Nm

For M5 screw M5 → 4.5–5 Nm

Check tightening torques after 24 hours of operation!

Additionally check tightening torques every 3 months for PP version!

If liquid still emerges from liquid end, the diaphragm is torn and must be replaced.

The service life of the metering diaphragm is dependent on

- system backpressure
- operating temperature
- properties of medium to be metered

The service life of the diaphragms is restricted in the case of abrasive media.

Flush liquid end of hazardous media:

- ▶ For this purpose force water or suitable flushing agent with a spray bottle through the intake connection of the liquid end.
- ▶ With pump running, set stroke length with control knob (14) to "0".
- ▶ Switch off pump.
- ▶ Release screws (24).
- ▶ Pull liquid end (4) with screws (24) out of end ring (3) and pump housing by approx. 5 mm until resistance can no longer be felt through screws (24) when turning the liquid end (4).
- ▶ Hold housing and end ring (3) in left hand and turn liquid end (4) in counterclockwise direction so that the diaphragm (25) is released from the drive shaft.
- ▶ Pull liquid end (4) with screws (24) out of diaphragm (25).
- ▶ Completely unscrew diaphragm (25) from drive shaft.
- ▶ Check condition of thread by screwing the new diaphragm on to the drive shaft as far as it will go and then screwing it off again.
- ▶ Re-install end ring (3) in housing.
- ▶ Fit diaphragm (25) in end ring (3) and screw on by 2 thread turns.



IMPORTANT

Turn diaphragm (25) such that the 4 holes of the diaphragm (25) and end ring (3) are precisely aligned! The outlet opening (26) of the end ring (3) must face downward.

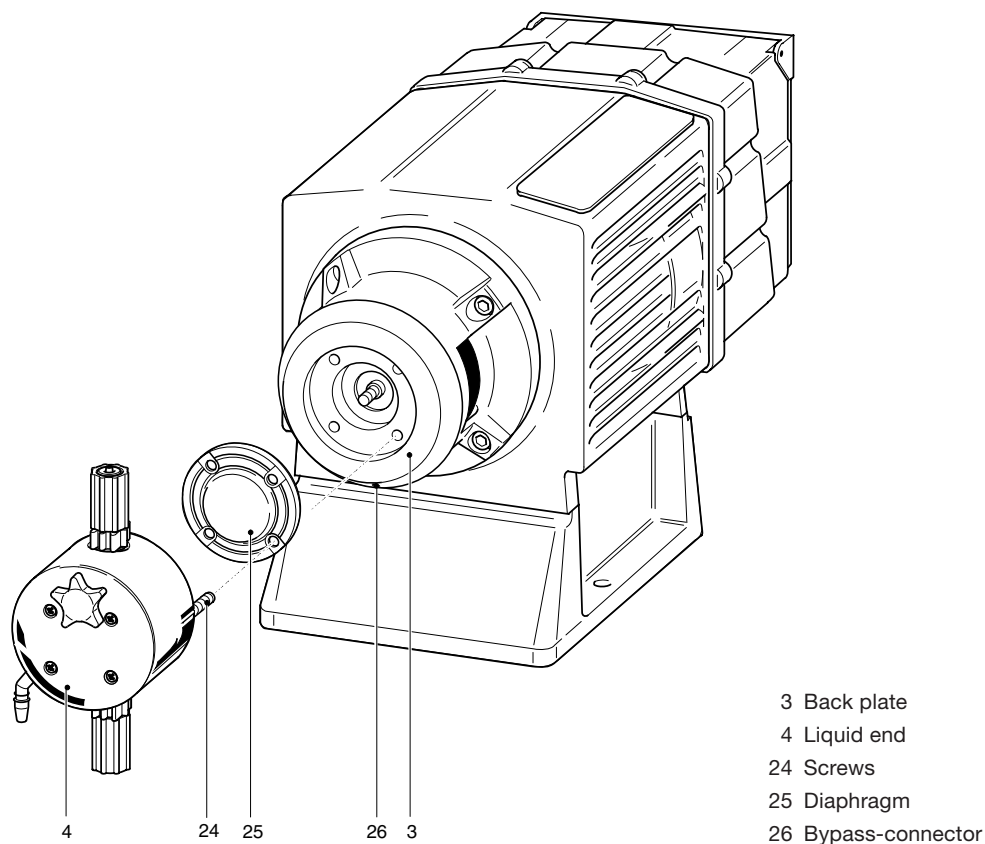

fig.: 8

- ▶ Fit liquid end (4) with screws (24) on diaphragm (25) and end ring (3) such that the parts can still turn (approx. 5 mm spacing between liquid end and end ring); the intake connection must face downwards.
- ▶ Now slowly turn parts in clockwise direction until the torsional resistance of the return spring can be felt and the diaphragm is fitted firmly.



IMPORTANT

Do not turn diaphragm too far!

- ▶ Switch on pump.
- ▶ Set stroke length with control knob (14) to 100 % and turn the complete delivery unit in clockwise direction until the intake connection faces vertically downward.
- ▶ Switch off pump
- ▶ Now tighten the 4 screws (24) crosswise



IMPORTANT

Observe tightening torques

For M4 screws M4 → 2.5–3 Nm

For M4 screws M5 → 4.5–5 Nm

Check tightening torques after 24 hours of operation.

Additionally check tightening torques every 3 months for PP version!

9.5 Pump does not reach high pressures or no suction despite max. stroke action

<i>Cause</i>	The working diaphragm has ruptured without setting off the alarm.
<i>Remedy</i>	Replace working diaphragm immediately (see “Changing the diaphragm”, section 8.1), change the separating diaphragm of the diaphragm rupture detector, check electrical connections of the diaphragm rupture detector (see section 8.4).

9.6 Diaphragm rupture indicator triggers alarm

<i>Cause</i>	The working diaphragm has ruptured; the diaphragm rupture detector cable is broken.
--------------	---

10 Used Part Disposal

NOTE

Metering pumps do not belong in the household waste!

Dispose of used parts in accordance with the law governing the avoidance and disposal of waste (Abfg) or in accordance with the waste and residual material monitoring ordinance governing the re-use of materials.

Your ProMinent dealer or representative will accept all used parts for a small cover charge. You will find the addresses on the back page of these operating instructions.

11 EXtronic section

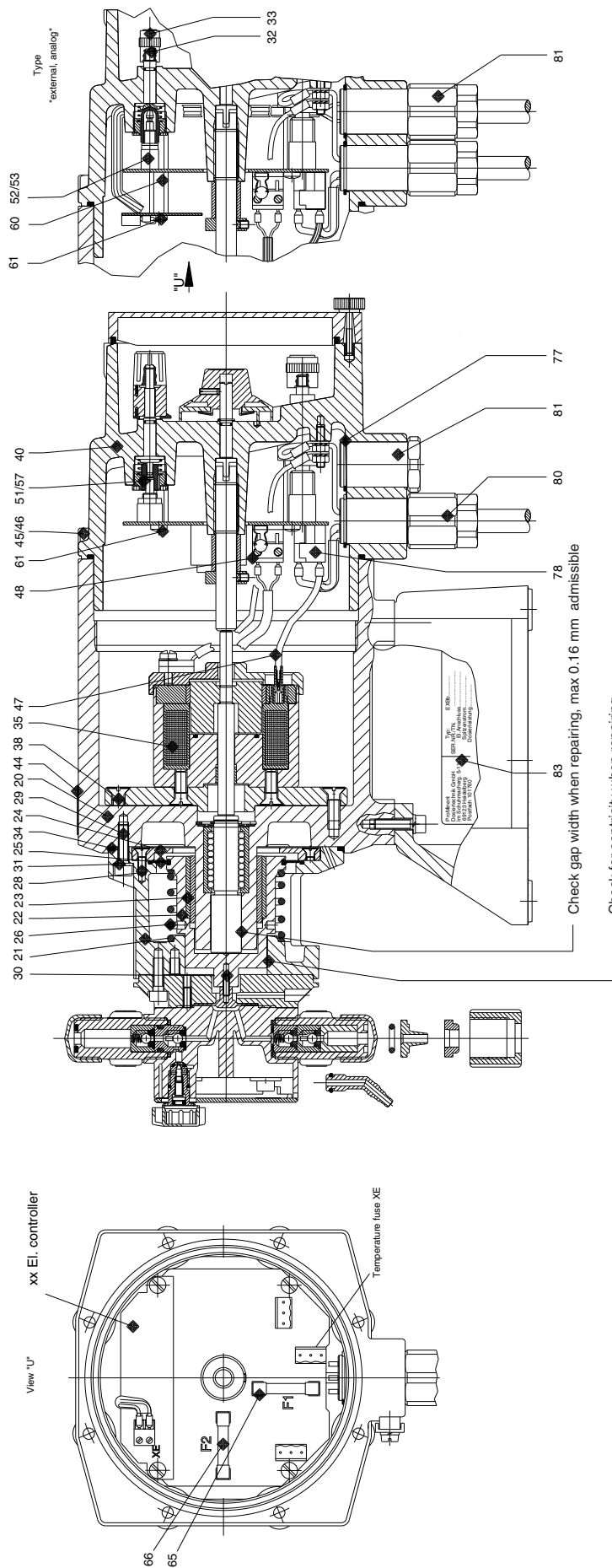

Thermo-fuse on the solenoid

100-230 V

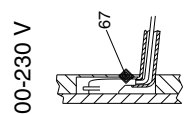

500 V

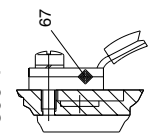

ATTENTION
Repairs must be carried out by skilled technicians!

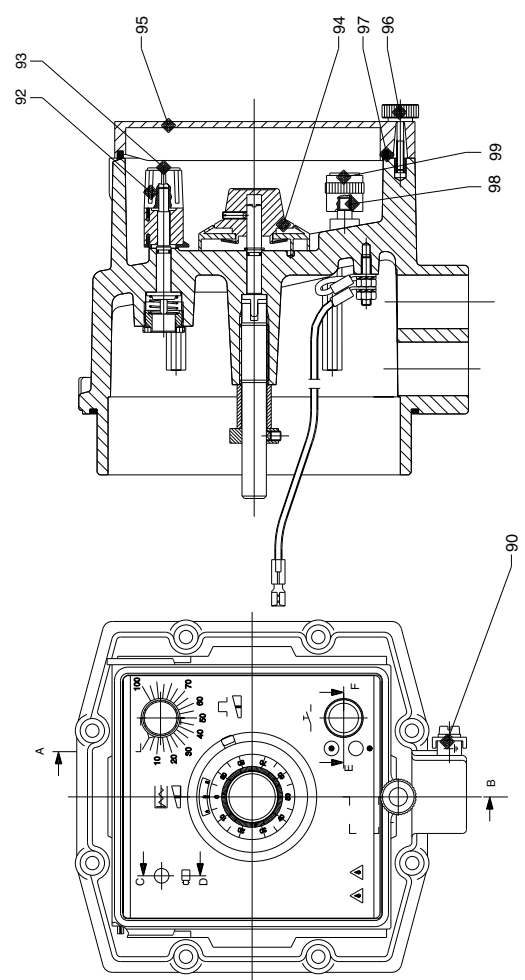

Spare parts

NOTE

Keep a number of spare fuses in stock.

Fuse item 65

Voltage	Pump types	Fuse data	Order no:
100 V	1000,1601, 1201, 0803, 1002, 0308	5x20 T 1.0A (1.5kA)	732409
100 V	2502,1006,0613,0417,1002HV	5x20 T 2.5A (1.5kA)	732413
100 V	2505,1310,0814,0430,0260	5x20 T 3.15A (1.5kA)	732414
115 V	1000,1601, 1201, 0803, 1002, 0308	5x20 T 630mA (1.5kA)	732407
115 V	2502,1006,0613,0417,1002HV	5x20 T 2.0A (1.5kA)	732412
115 V	2505,1310,0814,0430,0260	5x20 T 2.5A (1.5kA)	732413
200 V	1000,1601, 1201, 0803, 1002, 0308	5x20 T 400mA (1.5kA)	732405
200 V	2502,1006,0613,0417,1002HV	5x20 T 1.25A (1.5kA)	732410
200 V	2505,1310,0814,0430,0260	5x20 T 1.6A (1.5kA)	732411
230 V	1000,1601, 1201, 0803, 1002, 0308	5x20 T 315mA (1.5kA)	732404
230 V	2502,1006,0613,0417,1002HV	5x20 T 800mA (1.5kA)	732408
230 V	2505,1310,0814,0430,0260	5x20 T 1.25A (1.5kA)	732410
500 V	1000,1601, 1201, 0803, 1002, 0308	6.3x32 T 315mA 500V (1.5kA)	732371
500 V	2502,1006,0613,0417,1002HV	6.3x32 T 630mA 500V (1.5kA)	732372
500 V	2505,1310,0814,0430,0260	6.3x32 T 1.25A 500V (1.5kA)	733150

Fuse item 66

Voltage	Pump types	Fuse data	Order no:
100 ... 230V	All	5x20 T 160mA (35A)	712048

Customer:			
Project No.:	Date:	<input type="checkbox"/> Drawing enclosed	
Metering pump	Type	–
	Capacity	l/h
	Stroke rate	stroke/min
	Stroke length	%
	Valve spring pressure, intake side	bar
	Valve spring pressure, delivery side	bar
Medium	Description/ Concentration	– / % /
	Percentage solids/ grain size	% / mm /
	Solid material / hardness	– / (Mohs-Skala)
	Dynamic viscosity	mPa s (cP)
	Density	kg /m ³
	Vapour pressure at operating temp.	bar /°C
System, intake side	Pressure in intake tank	bar
	Nominal diameter intake line	DN / mm /
	Intake head min /max	m /
	Supply head min /max	m /
	Intake line length min /max	m
	Number of bracket/valves	–
	Pulsation damper	<input type="checkbox"/>	Diaphragm accumulator ltr.
		<input type="checkbox"/>	Pressure vessel ltr.
System, delivery side	Static system pressure min /max	bar /
	Nominal diameter of delivery line	DN / mm
	Delivery line length	m
	Delivery head	m
	Number of brackets/valve	–
	Pulsation damper	<input type="checkbox"/>	Diaphragm accumulator ltr.
		<input type="checkbox"/>	Pressure vessel ltr.

Guarantee Claim

Please copy and send in with the pump

In the case of failure of the metering pump within the guarantee period, please return the metering pump in a cleaned condition with the guarantee claim completed in full.



Please complete in full!

Guarantee claim for metering pumps	No.								
Company: Tel.-No.: Date: Address: Person responsible (customer): Order No.: Date of delivery: Pump type/ Identity code: Serial No.:									
Brief description of fault:									
Type of fault <table border="0"> <tr> <td data-bbox="113 1099 363 1126">1 Mechanical fault</td> <td data-bbox="783 1099 1007 1126">2 Electrical fault</td> </tr> <tr> <td data-bbox="113 1144 440 1346"> <input type="checkbox"/> Abnormal wear <input type="checkbox"/> Wearing parts <input type="checkbox"/> Breakage/ other damage <input type="checkbox"/> Corrosion <input type="checkbox"/> Damage during transport </td> <td data-bbox="783 1144 1345 1256"> <input type="checkbox"/> Connections such as connector or cable loose <input type="checkbox"/> Operating elements (e.g. switches) <input type="checkbox"/> Control </td> </tr> <tr> <td data-bbox="113 1406 268 1433">3 Leakage</td> <td data-bbox="783 1406 1197 1433">4 None or poor delivery capacity</td> </tr> <tr> <td data-bbox="113 1451 308 1520"> <input type="checkbox"/> Connections <input type="checkbox"/> Liquid end </td> <td data-bbox="783 1451 1062 1520"> <input type="checkbox"/> Diaphragm defective <input type="checkbox"/> Others </td> </tr> </table>		1 Mechanical fault	2 Electrical fault	<input type="checkbox"/> Abnormal wear <input type="checkbox"/> Wearing parts <input type="checkbox"/> Breakage/ other damage <input type="checkbox"/> Corrosion <input type="checkbox"/> Damage during transport	<input type="checkbox"/> Connections such as connector or cable loose <input type="checkbox"/> Operating elements (e.g. switches) <input type="checkbox"/> Control	3 Leakage	4 None or poor delivery capacity	<input type="checkbox"/> Connections <input type="checkbox"/> Liquid end	<input type="checkbox"/> Diaphragm defective <input type="checkbox"/> Others
1 Mechanical fault	2 Electrical fault								
<input type="checkbox"/> Abnormal wear <input type="checkbox"/> Wearing parts <input type="checkbox"/> Breakage/ other damage <input type="checkbox"/> Corrosion <input type="checkbox"/> Damage during transport	<input type="checkbox"/> Connections such as connector or cable loose <input type="checkbox"/> Operating elements (e.g. switches) <input type="checkbox"/> Control								
3 Leakage	4 None or poor delivery capacity								
<input type="checkbox"/> Connections <input type="checkbox"/> Liquid end	<input type="checkbox"/> Diaphragm defective <input type="checkbox"/> Others								
Operating conditions of ProMinent® -pumps Place of installation/ system description: Pump accessories used: Commissioning (date): Running period (approx. duty hours): Please specify installation data and enclose system drawing									

Declaration of Decontamination

(see download: www.prominent.com)

Because of legal regulations and for the safety of our employees and operation equipment, we need the „declaration of decontamination“, with your signature, before your order can be handled.

Please make absolutely sure to include it with the shipping documents, or – even better – attach it to the outside of the packaging.

Please return your products to:

Type of instrument / sensor: _____ Serial number: _____
 Gerätetyp: _____ Seriennummer: _____

Process data: Temperature: _____ [°C] Pressure: _____ [bar]
 Prozessdaten: Temperatur: _____ Druck: _____

Mediums and warnings:
 Warnhinweise zum Medium:



	Medium/ Concentration Medium/ Konzentration	Identi- fication CAS No.	flammable entzünd- lich	toxic giftig	corrosive ätzend	harmful/ irritant gesundheits- schädlich/reizend	other* sonstiges*	harmless unbedenklich
Process medium Medium im Prozess								
Medium for process- cleaning Medium zur Prozessreinigung								
Returned part cleaned with Medium zur Endreinigung								

* explosive; oxidising; dangerous for the environment; biological risk; radioactive
 * explosiv; brandfördernd; umweltgefährlich; biogefährlich; radioaktiv

Please tick should one of the above be applicable, include security sheet and, if necessary, special handling instructions.

Reason for return:

Company data: _____ Phone number: _____
 Company: _____ Fax: _____
 Contact person: _____ E-Mail: _____
 Street: _____ Your order No: _____
 Address: _____

“We hereby certify that the returned parts have been carefully cleaned. To the best of our knowledge they are free from any residues in dangerous quantities.”

 Place, date Company stamp and legally binding signature

- Original -

EC Declaration of Conformity for Machinery

We,

ProMinent Dosiertechnik GmbH
Im Schuhmachergewann 5 - 11
D - 69123 Heidelberg

hereby declare that the product specified in the following complies with the relevant basic health and safety rules of the EC Directive, on the basis of its functional concept and design and in the version marketed by us.
Any modification to the product not approved by use will invalidate this declaration.

Description of the product: *Metering pump, product range Extronic / b*

Product type: *EXBb...*

Serial no.: *Please refer to nameplate on the device*

Relevant EC Directives: *EC ATEX Directive (94/9/EC)*
EC - Machinery Directive (2006/42/EC)
The safety objectives of the Low Voltage Directive 2006/95/EC are complied with in accordance with Appendix I, No. 1.5.1 of the Machinery Directive 2006/42/EC

Harmonised standards applied, in particular: *EN 60079-0, EN 60079-1, EN 60079-11, EN 60079-26, EN 50303*
EN 1127-1, EN 13463-1, EN ISO 12100, EN 809, EN 60335-1, EN 60335-2-41 EN 61326-1

Technical documents have been compiled by: *Dr. Johannes Hartfiel*
Im Schuhmachergewann 5-11
D - 69123 Heidelberg

Date / Manufacturer's signature:

30/01/2012



Details of the signatory:

Joachim Schall, Head of Development



Translation

EC-Type Examination Certificate**- Directive 94/9/EC -****Equipment and protective systems intended for use
in potentially explosive atmospheres****DMT 03 ATEX E 023**

- (4) **Equipment:** Proportioning pump type EXBb M ... and Typ EXBb G ...
- (5) **Manufacturer:** ProMinent Dosiertechnik GmbH
- (6) **Address:** D 69007 Heidelberg
- (7) The design and construction of this equipment and any acceptable variation thereto are specified in the schedule to this type examination certificate.
- (8) The certification body of Deutsche Montan Technologie GmbH, notified body no. 0158 in accordance with Article 9 of the Directive 94/9/EC of the European Parliament and the Council of 23 March 1994, certifies that this equipment has been found to comply with the Essential Health and Safety Requirements relating to the design and construction of equipment and protective systems intended for use in potentially explosive atmospheres, given in Annex II to the Directive.
The examination and test results are recorded in the test and assessment report BVS PP 03.2087 EG and PP 2310/108/03 EG.
- (9) The Essential Health and Safety Requirements are assured by compliance with:
- | | |
|---------------------|--|
| EN 50014:1997+A1-A2 | General requirements |
| EN 50018:2000 +A1 | Flameproof enclosure |
| EN 50020:1994 | Intrinsic safety |
| EN 50284:1999 | Group II Category 1G |
| EN 50303:2000 | Group I Category M1-Apparatus |
| EN 1127-1:1997 | Explosive atmospheres - Explosion prevention and protection – Part 1: Basic concepts and Methodology |
| EN 13463-1:2001 | Non electrical equipment for potentially explosive atmospheres – part 1 Basic methods and requirements |
- (10) If the sign "X" is placed after the certificate number, it indicates that the equipment is subject to special conditions for safe use specified in the schedule to this certificate.
- (11) This EC-Type Examination Certificate relates only to the design, examination and tests of the specified equipment in accordance to Directive 94/9/EC.
Further requirements of the Directive apply to the manufacturing process and supply of this equipment. These are not covered by this certificate
- (12) The marking of the equipment shall include the following:

**further marking see table on the next page****Deutsche Montan Technologie GmbH**

Essen, dated 15. May 2003

Signed: Eickhoff

Signed: Schumann

DTM Certification body

Head of special services unit

Page 1 of 4 to DMT 03 ATEX E 023

This certificate may only be reproduced in its entirety and without change

Am Technologiepark 1, 45307 Essen, Telefon-Phone 0201/172-1416 Telefax-Fax 0201/172-1716
 Dinnendahlstrasse 9 44809 Bochum Germany Telefon-Phone +49 201/172-3923 Telefax-Fax +49 201/172-3924
 (bis 31.05. 2003: Deutsche Montan Technologie GmbH Dinnendahlstrasse 9 44809 Bochum Germany)



(13) Appendix to

(14) **EC-Type Examination Certificate**

DMT 03 ATEX E 023

(15) 15.1 Subject and type

Proportioning pump

type	⊕	marking
EXBb M ...	⊕	I M2 EEx d I II 2G EEx d IIC T6 I M2 c I II 2G c IIC T6
EXBb M ...	⊕	I M2 (M1) EEx d [ia] I II 2(1)G EEx d [ia] IIC T6 I M2 c I II 2G c IIC T6
EXBb M ...	⊕	I M2 EEx d I I M2 c I
EXBb M ...	⊕	I M2 (M1) EEx d [ia] I I M2 c I
EXBb G ...	⊕	II 2G EEx d IIC T6 II 2G c IIC T6
EXBb G ...	⊕	II 2(1)G EEx d [ia] IIC T6 II 2G c IIC T6

15.2 Description

The enclosure of the drive unit of the proportioning is designed in type of protection Flameproof Enclosure. Electronic assembly and electromagnet with a plunger, which penetrates the enclosure wall, are located inside this enclosure.

The electromagnet is triggered by pushbuttons and shafts or by electric signals, triggering the electronic assembly inside the enclosure. Optionally the type of protection of these triggering circuits is Intrinsic safety. (Type EXBb * * * * * 4 * *, type EXBb * * * * * 5 * *, type EXBb * * * * * 6 * * and type EXBb * * * * * 8 * *).

A diaphragm pump is mounted to the end wall of the flameproof enclosure.



15.3 Parameters

15.3.1 Supply circuits

15.3.1.1 Supply circuit (triggering circuit not intrinsically safe)

rated voltage	≤	AC 500	V
Maximum current input (I_{eff})		1,5	A
Maximum current		8	A
Maximum power input*		50	W

*averaged over the stroke cycle

15.3.1.2 Supply circuit (triggering circuit intrinsically safe)

Type EXBb * * * * * E * * *

rated voltage		AC	500 +6% -10%	V
max. voltage	Um	AC	530	V

Type EXBb * * * * * A * * *

rated voltage		AC	230 ±10%	V
max. voltage	Um	AC	253	V

Type EXBb * * * * * B * * *

rated voltage		AC	115 ±10%	V
max. voltage	Um	AC	253	V

Type EXBb * * * * * C * * *

rated voltage		AC	200 ±10%	V
max. voltage	Um	AC	253	V

Type EXBb * * * * * D * * *

rated voltage		AC	100 ±10%	V
max. voltage	Um	AC	253	V

15.3.2 Triggering circuits

15.3.2.1 Triggering circuits (not intrinsically safe)

voltage	≤	6	V
current	≤	30	mA

15.3.2.2 Triggering circuits (intrinsically safe)

Type EXBb * * * * * 4 * * and type EXBb * * * * * 8 * *

voltage	Uo	DC	7,14	V
current	Io		5	mA
power	Po		23,3	mW
internal resistance	Ri		4296	Ω
trapezoidal output characteristic				

max. external capacitance	Co		13,5	μF
max. external inductance	Lo		1	mH



Type EXBb * * * * * 5 * * and type EXBb * * * * * 6 * *
for connection of an intrinsically safe circuit

Spannung	Ui	DC	30	V
Stromstärke	Ii		280	mA
Leistung	Pi		2	W
effectiv internal inductance	Li		negligible	
effectiv internal capacitance	Ci		negligible	

15.3.3 Ambient temperature range - 20 °C up to + 45 °C

- (16) Test and assessment report
BVS PP 03.2087 EG, as of 15.05.2003
BVS PP 2310/108/03 EG, as of 29.04.2003

- (17) Special conditions for safe use
None

We confirm the correctness of the translation from the German original.
In the case of arbitration only the German wording shall be valid and binding.

44809 Bochum, 08.07.2003
BVS-Ru/Mi E 1364

EXAM BBG Prüf- und Zertifizier GmbH

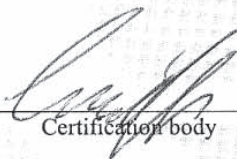
Certification body

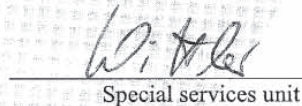
Special services unit

Translation

(1) **2. Supplement to the
EC-Type Examination Certificate**

- (2) Equipment and protective systems intended for use in potentially explosive atmospheres - Directive 94/9/EC Supplement accordant with Annex III number 6
- (3) No. of EC-Type Examination Certificate: **DMT 03 ATEX E 023**
- (4) Equipment: **Proportioning pump type EXBb M ... and EXBb G ...**
- (5) Manufacturer: **ProMinent Dosiertechnik GmbH**
- (6) Address: **69123 Heidelberg, Germany**
- (7) The design and construction of this equipment and any acceptable variation thereto are specified in the appendix to this supplement.
- (8) The certification body of DEKRA EXAM GmbH, notified body no. 0158 in accordance with Article 9 of the Directive 94/9/EC of the European Parliament and the Council of 23 March 1994, certifies that this equipment has been found to comply with the Essential Health and Safety Requirements relating to the design and construction of equipment and protective systems intended for use in potentially explosive atmospheres, given in Annex II to the Directive. The examination and test results are recorded in the test and assessment report BVS PP 03.2087 EG and BVS PP 2310/108/03 EG.
- (9) The Essential Health and Safety Requirements are assured by compliance with:
- | | |
|------------------|--|
| EN 60079-0:2009 | General requirements |
| EN 60079-1:2007 | Flameproof Enclosure |
| EN 60079-11:2007 | Intrinsic Safety |
| EN 60079-26:2007 | Equipment with EPL Ga |
| EN 50303:2000 | Equipment Group I Category M1-equipment |
| EN 1127-1:2011 | Explosion prevention and protection - Part 1: Basic concepts and methodology |
| EN 13463-1:2009 | Non-electrical equipment for potentially explosive atmospheres - Part 1: Basic method and requirements |
- (10) If the sign "X" is placed after the certificate number, it indicates that the equipment is subject to special conditions for safe use specified in the appendix to this certificate.
- (11) This supplement to the EC-Type Examination Certificate relates only to the design, examination and tests of the specified equipment in accordance to Directive 94/9/EC. Further requirements of the Directive apply to the manufacturing process and supply of this equipment. These are not covered by this certificate.
- (12) The marking of the equipment shall include the following:



See table under 15.1

DEKRA EXAM GmbH
Bochum, dated 05.01.2012

Signed: Simanski

Certification body

Signed: Dr. Eickhoff

Special services unit



- (13) Appendix to
- (14) **2. Supplement to the EC-Type Examination Certificate**
DMT 03 ATEX E 023
- (15) 15.1 Subject and type

Proportioning pump

Type		Marking	
EXBb M ...	⊕ _{Ex}	I M2 Ex d I Mb II 2G Ex d IIC T6 Gb	I M2 c I Mb II 2G c IIC T6 Gb
EXBb M ...	⊕ _{Ex}	I M2 (M1) Ex d [ia Ma] I Mb II 2(1)G Ex d [ia Ga] IIC T6 Gb	I M2 c I II 2G c IIC T6
EXBb M ...	⊕ _{Ex}	I M2 Ex d I Mb	I M2 c I Mb
EXBb M ...	⊕ _{Ex}	I M2 (M1) Ex d [ia Ma] I Mb	I M2 c I Mb
EXBb G ...	⊕ _{Ex}	II 2G Ex d IIC T6 Gb	II 2G c IIC T6 Gb
EXBb G ...	⊕ _{Ex}	II 2(1)G Ex d [ia Ga] IIC T6 Gb	II 2G c IIC T6 Gb

15.2 Description

Reason for this supplement is to certify the conformity to the latest standards. Additionally an intrinsically safe diaphragm breaking detector (PTB 00 ATEX E 2048 X) can be fitted to the front side

15.3 Parameters

15.3.1 Supply circuit

15.3.1.1 Supply circuit (triggering circuit not intrinsically safe)

Rated voltage		AC	≤ 500	V
Maximum current input (I _{eff})			1,5	A
Maximum current			8	A
Maximale power input (averaged over the stroke cycle)			50	W

15.3.1.2 Supply circuit (triggering circuit intrinsically safe)

Type EXBb * * * * * E * * *

Rated voltage		AC	500 +6 % -10 %	V
Maximum voltage	Um	AC	530	V

Type EXBb * * * * * A * * *

Rated voltage		AC	230 ±10 %	V
Maximum voltage	Um	AC	253	V

Type EXBb * * * * * B * * *

Rated voltage		AC	115 ±10 %	V
Maximum voltage	Um	AC	253	V

Type EXBb * * * * * C * * *

Rated voltage		AC	200 ±10 %	V
Maximum voltage	Um	AC	253	V

Type EXBb * * * * * D * * *

Rated voltage		AC	100 ±10 %	V
Maximum voltage	Um	AC	253	V



15.3.2 Triggering circuits

15.3.2.1 Triggering circuits (not intrinsically safe)

Voltage	≤	6	V
Current	≤	30	mA

15.3.2.2 Triggering circuits (intrinsically safe)

Maximum output voltage	Uo	DC	7.14	V
Maximum output current	Io		5	mA
Maximum output power	Po		23.3	mW
Internal resistance	Ri		4296	Ω
trapezoidal output characteristic				
Maximum external capacitance	Co		13.5	μF
Maximum external inductance	Lo		1	H

for the connection of an intrinsically safe circuit

Maximum input voltage	Ui	DC	30	V
Maximum input current	Ii		280	mA
Maximum input power	Pi		2	W
Effective internal inductance	Li		negligible	
Effective internal capacitance	Ci		negligible	

15.3.2.3 Diaphragm breaking detector (intrinsically safe)

Maximum input voltage	Ui	DC	8	V
Nominal current			1	mA
Maximum input current	Pi		3	mA
Maximum internal inductance	Li		50	μH
Maximum internal capacitance	Ci		30	nF

15.3.3 Ambient temperature range Ta -20 °C up to +45 °C

(16) Test and Assessment Report

BVS PP 03.2087 EG as of 05.01.2012

BVS PP 2310/108/03 EG as of 13.12.2011

(17) Special conditions for safe use

None

We confirm the correctness of the translation from the German original.
In the case of arbitration only the German wording shall be valid and binding.

DEKRA EXAM GmbH
44809 Bochum, 05.01.2012
BVS-Kir/Sch A 20100015



Certification body



Special services unit

Anschriften- und Liefernachweis durch den Hersteller /
Addresses and delivery through manufacturer /
Adresses et liste des fournisseurs fournies par le constructeur /
Para informarse de las direcciones de los distribuidores, dirigirse al fabricante:

ProMinent Dosiertechnik GmbH
Im Schuhmachergewann 5-11
69123 Heidelberg
Germany

Tel.: +49 6221 842-0
Fax: +49 6221 842-419

info@prominent.com
www.prominent.com