

Operating instructions

Diaphragm motor-driven metering pump

Sigma/ 2 Basic type S2Ba

EN

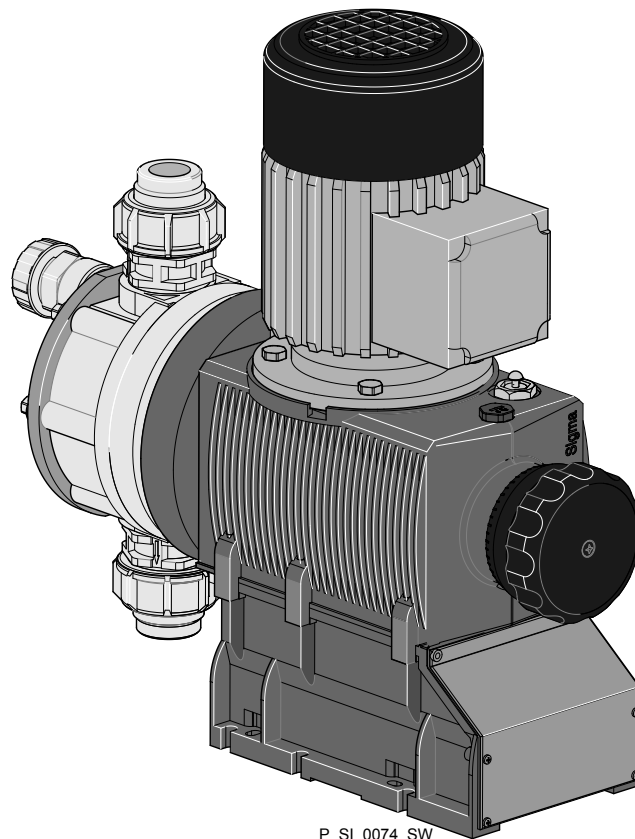

P_SI_0074_SW

Target group: Minimally instructed personnel

**Please carefully read these operating instructions before use. · Do not discard.
The operator shall be liable for any damage caused by installation or operating errors.
The latest version of the operating instructions are available on our homepage.**

Supplementary information



Fig. 1: Please read!

Read the following supplementary information in its entirety! Should you already know this information, you will benefit more from referring to the operating instructions.

The following are highlighted separately in the document:

- Enumerated lists

- ➔ Operating guidelines

- ⇒ Outcome of the operating guidelines

- see (reference)

Information



This provides important information relating to the correct operation of the unit or is intended to make your work easier.

Safety notes

Safety notes are identified by pictograms - see Safety Chapter.

Validity

These operating instructions conform to current EU regulations applicable at the time of publication.

State the identity code and serial number

Please state identity code and serial number, which you can find on the nameplate when you contact us or order spare parts. This enables the device type and material versions to be clearly identified.

Table of contents

1	Identity code	5
1.1	Explanation of the ATEX label.....	6
2	Safety chapter	9
2.1	Markings and warning symbols.....	9
2.2	Intended use.....	9
2.3	Personnel qualification.....	10
2.4	Safety information.....	11
2.5	Isolating protective equipment.....	13
2.6	Requirements if the motor is being installed independently..	13
2.7	Safety information for ATEX designs.....	14
2.7.1	Intended use.....	14
2.7.2	ATEX qualification of personnel.....	14
2.7.3	ATEX safety information.....	15
2.7.4	Potential equalisation lines and other features.....	19
2.7.5	ATEX features.....	20
2.7.6	Safety equipment.....	21
2.8	Explanation of the ATEX label.....	22
3	Storage, transport and unpacking	25
4	Overview of equipment and control elements	26
5	Functional description	28
5.1	Pump.....	28
5.2	Liquid end.....	28
5.3	Integral relief valve.....	28
5.4	Multi-layer safety diaphragm.....	29
6	Assembly	30
6.1	Assembly of the motor - with designs without motor.....	30
6.2	Base.....	31
6.3	Space requirement.....	31
6.4	Fastening.....	32
7	Installation, hydraulic	33
7.1	Basic installation notes.....	36
8	Installation, electrical	37
9	Start up	42
10	During operation	46
11	Maintenance	47
11.1	Safety information.....	47
11.2	Inspection, daily.....	48
11.3	Standard liquid ends.....	48
12	Repair	51
12.1	Safety information, repair.....	51
12.2	Cleaning valves.....	51
12.3	Replacing the diaphragm.....	53
13	Troubleshooting	57
14	Decommissioning	60
15	Technical data	62
15.1	Performance data.....	62
15.2	Viscosity.....	63
15.3	Shipping weight.....	64
15.4	Wetted materials.....	64
15.5	Ambient conditions.....	64
15.5.1	Ambient temperatures.....	64

15.5.2	Media temperatures.....	64
15.5.3	Air humidity.....	65
15.6	Installation height.....	65
15.7	Motor data.....	65
15.8	Stroke actuator.....	66
15.9	Stroke control drive.....	66
15.10	Diaphragm rupture sensor.....	66
15.11	Stroke sensor "Sigma".....	67
15.12	Relays.....	67
15.13	Gear oil.....	68
15.14	Sound pressure level.....	68
15.15	Supplementary information for modified versions.....	68
16	Diagrams for setting the metering capacity.....	69
17	Dimensional drawings.....	70
18	Potential equalisation drawings for Sigma Basic Type.....	72
19	Motor data sheet standard motor.....	73
20	Exploded drawings for Sigma/ 2.....	74
21	Wear parts of Sigma/ 2.....	79
	21.1 Standard.....	79
	21.2 Physiological safety.....	79
22	Declaration of Conformity for Machinery.....	81
23	Declaration of Incorporation for Machinery.....	82
24	Declaration of Conformity for ATEX Machinery.....	83
25	Declaration of Conformity for ATEX Machinery.....	84
26	Index.....	85

1 Identity code

S2Ba	Sigma 2 Basic type	
H	Main power end, diaphragm	
	Type:	Output
	----	Performance data at maximum back pressure and type: refer to nameplate on the pump housing
	Dosing head material	
	PV	PVDF
	SS	stainless steel
	TT	PTFE + carbon
	Seal material	
	T	PTFE seal
	F	FDA-compliant
	G	1935/2004 (10/2011)
	H	Hygienic design
	Displacement body	
	S	Multi-layer safety diaphragm with optical rupture indicator
	A	Multi-layer safety diaphragm with diaphragm rupture signalling (contact)
	Dosing head version	
	0	no valve springs
	1	with 2 valve springs, Hastelloy® C; 0.1 bar
	4 **	with relief valve, FPM seal, no valve springs
	5 **	with relief valve, FPM seal, with valve springs
	6 **	with relief valve, EPDM seal, no valve spring
	7 **	with relief valve, EPDM seal, with valve spring
	H	Hygienic pump head with tri-clamp connectors (max. 10 bar)
	Hydraulic connector	
	0	Standard threaded connector (in line with the technical data)
	1	Union nut and PVC insert
	2	Union nut and PP insert
	3	Union nut and PVDF insert
	4	Union nut and SS insert
	7	Union nut and PVDF hose sleeve
	8	Union nut and SS hose sleeve
	9	Union nut and SS welding sleeve
	C	Aseptic clamp fitting DIN 11864-3 (Standard for hygienic design)
	Design	
	0	with ProMinent-Logo (standard)
	1	without ProMinent logo
	M	modified, order-specific design, see order paperwork for pump features

S2Ba		Sigma 2 Basic type	
		Electric power supply	
		_	Connection data - see motor nameplate
		S	3-phase, 230/400 V, 50/60 Hz
		T	3-phase, 230/400 V, 50/60 Hz, with PTC
		R	Speed control motor, 3-phase 230/400 V, 50 Hz, with PTC
		1	no motor, with B14 flange, size 71 (DIN)
		2	no motor, with C 42 flange (NEMA)
		3	no motor, with B 5, size 56 (DIN)
		Degree of protection	
		0	IP 55 (standard)
		1	Exe design ATEX-T3 ***
		2	Exd design ATEX-T4 ***
		Stroke sensor	
		0	no stroke sensor (standard)
		2	Pacing relay (reed relay)
		3	Stroke sensor (Namur) for areas at risk from explosion
		Stroke length adjustment	
		0	manual (standard)
		1	with servomotor, 85 ... 265 V, 50/60 Hz
		4	with stroke control motor 0/4...20 mA, 85 ... 265 V, 50/60 Hz

FPM = fluorine rubber

** Standard with hose sleeve in the bypass. Threaded connection on request.

*** ATEX specification - refer to the nameplate on the pump, corresponding EU Declaration of Conformity for ATEX Machinery and [Chapter 1.1 'Explanation of the ATEX label' on page 6](#)

1.1 Explanation of the ATEX label

in accordance with Directive 2014/34/EU and standards EN ISO 80079-36, -37

Explanation of the pump's ATEX labelling Sigma/ 2	
Unit group	
II	No mines or associated underground systems, which can be endangered by firedamp - Unit for use in other areas at risk from explosion
Other parameters	
3G Ex h	(Example)
Explosion group	
IIC	for explosion group IIC gas - refer to your explosion protection document

Explanation of the pump's ATEX labelling Sigma/ 2

			IIB	for explosion group IIB gas - refer to your explosion protection document
			Temperature class	
			T3	for Temperature class T3 gas - refer to your explosion protection document
			T4	for Temperature class T4 gas - refer to your explosion protection document
			Equipment protection level (EPL)	
			Gb	high EPL use possible in zones 1 and 2 - refer to your explosion protection document
			Gc	normal EPL use possible in zone 2 - refer to your explosion protection document
			Suffix X	
			X	Special conditions - refer to the Declarations of Conformity and EC-type examination certificates

**WARNING!****Example of EX-designation: Where may I use the ATEX version of the Sigma/ 2?**

The pump designation is:

" ... II 3G Ex h IIB T4 Gc".

The pump label corresponds to "Unit group" II: the pump may only be used in overground production systems, which are not at risk from firedamp.

The inserted pump label "3G Ex h" does not need to be discussed here.

The additional pump label in the example states "Explosion group" IIB and "Temperature class" T4:

The  *Tab. 1 'Example of the division of gases into explosion groups and temperature classes' on page 8* is shown as an example: the pump can be used for ethyl ether or a comparable gas - refer to the material safety data sheet for the gas or your explosion protection document.

The pump in the example could also be suitable for gases that require only "Explosion group" IIA and "Temperature class" T3, T2 or T1 - but not for T5 and T6.

"EPL" Gc is shown in the next example: Use only in zone 2 – but not in zone 1 or zone 0.

Tab. 1: Example of the division of gases into explosion groups and temperature classes

	T6 85 °C	T5 100 °C	T4 135 °C	T3 200 °C	T2 300 °C	T1 450 °C
IIC	Carbon disulphide	-	Trichlorosilane	-	Ethyne	Hydrogen
IIB	-	-	Ethyl ether	-	Ethene	Mains gas (coal gas)
IIA	-	-	Acetaldehyde	Benzine, Diesel fuel, Aircraft fuel, Heating oils, n-hexane	Ethanol, n-butane, n-butyl alcohol	Acetone, Ammonia, Benzene (pure), Acetic acid, Ethane, Ethyl acetate, Carbon oxide, Methanol, Propane, Toluene



WARNING!

Example 2 - EX-designation: Where may I use the ATEX version of the Sigma/ 2?

The pump designation is " ... II 2G Ex h IIC T4 Gb X".

The pump label corresponds to "Unit group" II: the pump may only be used in overground production systems, which are not at risk from firedamp.

The inserted pump label "2G Ex h" does not need to be discussed here.

The pump label is shown in the example "Explosion group" IIC and "Temperature class" T4:

The ↪ *Tab. 1 'Example of the division of gases into explosion groups and temperature classes' on page 8* shows the following: the pump can be used for all gases of "Explosion group" IIC and "Temperature class" T4 - refer to your explosion protection document.

The pump in the example could also be suitable for gases that require only "Explosion group" IIB or IIA and "Temperature class" T3, T2 or T1 – but not for T5 and T6.

"EPL" Gb is shown in the next example: use is possible in zone 1 and zone 2 – but not in zone 0.

"X" indicates "Special conditions" - see EU Declaration of Conformity or type test certification for the pump or additional assemblies. This might involve another lower limit for the ambient temperature, e.g. -10 °C .

2 Safety chapter

These operating instructions include notes and extracts from German regulations relating to the operator's scope of responsibility. The notes and quotes do not in any way release the operator from his/her responsibility as operator. The notes and quotes are only intended to remind the operator or make them aware of specific problem areas. The notes and quotes do not in any way claim to be complete, nor applicable to every country and every type of application, nor to being unconditionally up-to-date.

2.1 Markings and warning symbols



Identification of safety notes

The following signal words are used in these operating instructions to denote different severities of danger:

Signal word	Meaning
WARNING	Denotes a possibly dangerous situation. If this is disregarded, you are in a life-threatening situation and this can result in serious injuries.
CAUTION	Denotes a possibly dangerous situation. If this is disregarded, it could result in slight or minor injuries or material damage.

Warning signs denoting different types of danger

The following warning signs are used in these operating instructions to denote different types of danger:

Warning signs	Type of danger
	Warning – high-voltage.
	Warning – danger zone.

2.2 Intended use



NOTICE!

Wear caused by "Pump ON/OFF" using the mains connection

Frequent switching of the pump on and off (>2 times each day) using the supply voltage leads to increased wear in the pump. The pump is not technically designed for this.

If necessary, use the "Pause" function to switch the pump to standby mode. Do not switch the pump on and off using the supply voltage to spare a pause input.

- Only use the pump to meter liquid feed chemicals.
- Pumps with the identity code option "Multi-layer safety diaphragm with rupture signalling (contact)" are only approved for use with flammable feed chemicals with electrically conductive dosing heads, at back pressures of over 2 bar and only if the operator takes appropriate safety measures.
Pumps with the identity code option "Multi-layer safety diaphragm with rupture signalling (contact)" are only approved for use with hazardous feed chemicals, at back pressures of over 2 bar and only if the operator takes appropriate safety measures.
- Pumps with the identity code option "Multi-layer safety diaphragm with rupture signalling (contact)" are only approved for use with hazardous feed chemicals, at back pressures of over 2 bar and only if the operator takes appropriate safety measures.
- Only "H - Hygienic head" design of pumps may be used for applications in accordance with the hygiene requirements of closed processes and wet cleaning without dismantling.
- Only use the pump once it has been correctly installed and started up in accordance with the technical data and specifications contained in the operating instructions.
- Observe the general limitations with regard to viscosity limits, chemical resistance and density - see also the ProMinent Resistance List (in the Product Catalogue or at www.prominent.com)!
- All other uses or modifications are prohibited.
- The pump is not designed to meter gaseous media and solids.
- The pump is not intended for the metering of explosive substances and mixtures.
- The pump is not intended for unprotected use outdoors.
- The pump is not intended for private use.
- Only trained and authorised personnel should be allowed to operate the pump - see the table below.
- You have a duty to observe the information contained in the operating instructions during the different phases of the service life of the unit.
- You have a responsibility to observe the information contained in the operating instructions for the auxiliary equipment at the different phases of its respective service life.
- ATEX designs only: Refer to the chapter " ↪ Chapter 2.7 'Safety information for ATEX designs' on page 14".

2.3 Personnel qualification

Task	Qualification
Storage, transport, unpacking	Instructed person
Assembly	Technical personnel, Service
Planning the hydraulic installation	Qualified personnel with a thorough knowledge of oscillating displacement pumps
Hydraulic installation	Technical personnel, Service
Electrical installation	Electrical technician
Start up	Technical personnel
Operation	Instructed person
Maintenance, repair	Technical personnel, Service
Decommissioning, disposal	Technical personnel, Service
Troubleshooting	Qualified person, electrical technician, instructed person, Service - depending on the requirement

Explanation of the table:**Trained, qualified personnel**

A trained, qualified employee is deemed to be a person who is able to assess the tasks assigned to him and recognise possible hazards based on his training, knowledge and experience, as well as knowledge of pertinent regulations. A trained, qualified employee must be able to perform the tasks assigned to him/her independently with the assistance of drawing documentation and parts lists. The assessment of a person's technical training can also be based on several years of work in the relevant field.

Electrical technician

An electrical technician is able to complete work on electrical systems and recognise and avoid possible dangers independently based on their technical training and experience as well as knowledge of pertinent standards and regulations. An electrical technician must be able to perform the tasks assigned to him/her independently with the assistance of drawing documentation, parts lists, terminal and circuit diagrams. The electrical technician must be specifically trained for the working environment in which the electrical technician is employed and be conversant with the relevant standards and regulations.

Instructed person

An instructed person is deemed to be a person who has been instructed and, if required, trained in the tasks assigned to him/her and possible dangers that could result from improper behaviour, as well as having been instructed in the required protective equipment and protective measures.

Trained user

A trained user is a person who fulfils the requirements demanded of an instructed person and who has also received additional training specific to the system from ProMinent or another authorised distribution partner.

Service

Service refers to service technicians who have received certified training and have been authorised by ProMinent to work on the system.

2.4 Safety information

Safety information

**WARNING!****Warning of hazardous feed chemical**

Should a dangerous feed chemical be used: it may escape from the hydraulic components when working on the pump, material failure or incorrect handling of the pump.

- Take appropriate protective measures before working on the pump (e.g. safety glasses, safety gloves, ...). Adhere to the material safety data sheet for the feed chemical.
- Drain and flush the liquid end before working on the pump.



WARNING!

Danger from hazardous substances!

Possible consequence: Fatal or very serious injuries.

Please ensure when handling hazardous substances that you have read the latest safety data sheets provided by the manufacture of the hazardous substance. The actions required are described in the safety data sheet. Check the safety data sheet regularly and replace, if necessary, as the hazard potential of a substance can be re-evaluated at any time based on new findings.

The system operator is responsible for ensuring that these safety data sheets are available and that they are kept up to date, as well as for producing an associated hazard assessment for the workstations affected.



CAUTION!

Warning of feed chemical spraying around

Feed chemical may spray out of the hydraulic components if they are tampered with or opened due to pressure in the liquid end and adjacent parts of the system.

- Disconnect the pump from the mains power supply and ensure that it cannot be switched on again by unauthorised persons.
- Ensure that the system is at atmospheric pressure before commencing any work on hydraulic parts of the system.



CAUTION!

Warning of feed chemical spraying around

An unsuitable feed chemical can damage the parts of the pump that come into contact with the chemical.

- Take into account the resistance of the wetted materials and the ProMinent Resistance List when selecting the feed chemical - see the ProMinent Product Catalogue or visit ProMinent.



WARNING!

Danger of injury to personnel and material damage

The pump must only be opened at those points required to be opened by these operating instructions.

It may only be opened in other positions upon receipt of written authorisation from the ProMinent head office, Heidelberg.



CAUTION!

Danger of personnel injury and material damage

The use of untested third party parts can result in personnel injuries and material damage.

- Only fit parts to metering pumps, which have been tested and recommended by ProMinent.



CAUTION!

Danger from incorrectly operated or inadequately maintained pumps

Danger can arise from a poorly accessible pump due to incorrect operation and poor maintenance.

- Ensure that the pump is accessible at all times.
- Adhere to the maintenance intervals.

Information in the event of an emergency

In the event of an electrical accident, disconnect the mains cable from the mains/power supply or press the emergency cut-off switch fitted on the side of the system.

If feed chemical escapes, ensure that the hydraulic environment around the pump is at atmospheric pressure as well. Refer to the material safety data sheet for the feed chemical.

Safety information for operating instructions

Prior to commissioning the system or system component, it is the responsibility of the system operator to obtain the latest material safety data sheet for the chemicals / equipment to be used with the system from the supplier. Based on the information provided in the data sheets concerning health and safety, water and environmental protection, and taking into consideration the actual operating environment on site, it is the responsibility of the operator to create the legal framework for the safe operation of the system or system component, such as for example the preparation of operating instructions (operator's duties).

2.5 Isolating protective equipment

All isolating protective equipment must be installed for operation:

Protective equipment	May only be removed by*:
Motor terminal box cover	Electrical technician, ATEX electrical technician, Service
Protective cowling over the motor fan	Service
Power end front cover	Service

* Only if required by the operating instructions and if the mains cable remains disconnected from the mains voltage.

2.6 Requirements if the motor is being installed independently

The operator must be able to:

- Perform a risk assessment
- Produce and attach a nameplate
- Issue a Declaration of Conformity
- Adapt the operating instructions, if necessary
- Install the motor correctly

Install the motor - with designs without motor

1. ➔ Select a suitable motor - it must correspond to the data for one of the motors from the "Motor data" table - see Chapter "Technical data"
2. ➔ Fit the motor correctly on the flange (qualified personnel).

3. ▶ As you have converted an "incomplete machine" into a complete machine, you must perform a conformity assessment, risk assessment, create a Declaration of Conformity, fit a company name-plate,
4. ▶ Complete the pump documentation / operating instructions.

Sound pressure level

Sound pressure level LpA < 70 dB according to EN ISO 20361
at maximum stroke length, maximum stroke rate, maximum back pressure (water)

2.7 Safety information for ATEX designs

This chapter lists all safety information for ATEX designs. Safety information is listed again at the relevant points in these operating instructions.

This safety information is supplementary to or replaces the safety information for non-ATEX designs. If the safety information for ATEX designs contradicts the other safety information, then the safety information in this chapter applies to ATEX designs.

2.7.1 Intended use

- Only operate an ATEX design of pump in premises at risk from explosion in accordance with the applicable guidelines.
- Pumps with the identity code option "Multi-layer safety diaphragm with rupture signalling (contact)" are only approved for use with flammable feed chemicals with electrically conductive dosing heads, at back pressures of over 2 bar and only if the operator takes appropriate safety measures. Rupture signalling must switch off the pump immediately.
- Do not expose the ATEX design to any sources of ionising radiation or electromagnetic high frequency radiation in the range $10^4 \dots 3 \times 10^{15}$ Hz or laser radiation or ultrasound or lightning without putting in place measures in line with EN 80079-38.
- Do not allow the ATEX design to meter media, which tends to produce exothermic reactions or self-ignite (examples of exothermic reactions: pyrophoric substances with air, alkali metal with water, decomposition of organic peroxides, polymerisation reactions), without taking effective measures in accordance with EN 80079-38.

2.7.2 ATEX qualification of personnel

Task	Qualification
Planning the hydraulic installation	ATEX qualified person, ATEX electrical technician
Electrical installation	ATEX electrical technician
Start up	Skilled ATEX technician; Checking the electrical installation: Recognised competent person
Maintenance, repair	ATEX qualified person, ATEX electrical technician
Troubleshooting	Qualified ATEX technician or ATEX electrical technician - depending on the fault; Checking the electrical installation: Recognised competent person

Explanation of the table:

Recognised competent person

To carry out explosion hazard inspections the competent person must have:

- completed a relevant course of study or
- have a comparable technical qualification or
- another technical qualification combined with long-term experience of safety technology.

The person must have knowledge of the relevant body of standards and regulations and have worked in the field for at least one year. The person needs to have opportunities for an exchange of experiences.

Competent persons who perform tests on repaired equipment/parts are subject to specific requirements. They must be **recognised** by the responsible authorities (e.g. district council) in this respect.

Skilled technician with knowledge of ATEX explosion protection

The skilled technician with an additional explosion protection qualification should be specifically trained for the work area in which he/she is employed and be familiar with the relevant standards and regulations. The skilled technician with an additional explosion protection qualification can work on equipment and systems in areas protected from explosion and independently recognise and avoid possible dangers based on his/her technical training and experience.

The skilled technician with an additional explosion protection qualification is familiar with all the standards and regulations applicable to explosion protection.

The skilled technician with an additional explosion protection qualification must comply with the provisions of the applicable statutory directives on accident prevention.

Electrical technician with knowledge of ATEX explosion protection

An electrical technician with an additional explosion protection qualification should be specifically trained for the field of work in which they are employed and be familiar with the relevant standards and regulations. An electrical technician with an additional explosion protection qualification can work on electrical systems and independently recognise and avoid possible dangers based on their technical training and experience.

The electrical technician with an additional explosion protection qualification is familiar with all the standards and regulations applicable to explosion protection.

An electrical technician with an additional explosion protection qualification must comply with the provisions of the applicable statutory directives on accident prevention.

Recognised competent person

To carry out explosion hazard inspections the competent person must have:

- completed a relevant course of study or
- have a comparable technical qualification or
- another technical qualification combined with long-term experience of safety technology.

The person must have knowledge of the relevant body of standards and regulations and have worked in the field for at least one year. The person needs to have opportunities for an exchange of experiences.

Competent persons who perform tests on repaired equipment/parts are subject to specific requirements. They must be recognised by the responsible authorities (e.g. district council) in this respect.

2.7.3 ATEX safety information

Summary of relevant ignition hazards and protective measures put in place for the Sigma in accordance with EN ISO 80079-36

Ignition hazard	Protective measures to be observed by the customer
Excessive surface pressure	Limitation of the maximum temperature of the feed chemical
Too low ambient temperature	Limitation of the minimum ambient temperature
Pump running hot	<p>The customer must monitor and maintain the pump in accordance with the "Maintenance" chapter.</p> <p>The customer must fit a relief valve on the discharge side.</p>
Mechanically generated sparks from the mechanism with low oil	The customer must monitor and maintain the pump in accordance with the "Maintenance" chapter.
Mechanically generated sparks from a faulty valve	The customer must monitor the capacity.
Electrical stray current in the event of a short circuit	The customer must earth the pump and maintain the earthing of the individual components.
Electrical stray current in the event of a lightning strike	The customer must put in place suitable protective measures outdoors.
Static electricity	<p>The customer must earth the earthing points and maintain the potential equalisation cables of the individual components.</p> <p>The customer must pay attention to potential equalisation when dismantling.</p> <p>Paint should not be applied too thickly.</p> <p>Only clean plastic parts with a damp cloth.</p> <p>Provide a temperature monitor on the dosing head with feed chemical with critical friction properties.</p> <p>The customer must wire the diaphragm rupture indicator in such a way that it immediately stops the pump.</p>
Electromagnetic waves (also lasers), ionising radiation and ultrasound have an impact on the pump	The customer must put in place measures in accordance with EN 1127-1, if need be.
Adiabatic compression and shock waves	Feed chemical with electrical conductivity of < 50 pS/m, which could form a combustible mixture: Do not allow the unit to run dry – even when filling and emptying the liquid end.
Exothermic reaction, including the self-combustion of dust	The pump is not suitable for use with substances that have a tendency towards exothermic reactions or self-combustion. Put in place measures in accordance with EN 1127-1, if need be.
Deposits of dust	Regularly clean the outside of the pump with a damp cloth.
Flammable feed chemicals	<p>Only material version SS or TT is permitted to pump flammable feed chemicals.</p> <p>Do not allow it to run dry.</p> <p>The operator must install suitable protective measures, for example a flow meter.</p> <p>The customer must wire the diaphragm rupture indicator in such a way that it immediately stops the pump.</p>

Ignition hazard	Protective measures to be observed by the customer
Ignition hazard with bought-in motor components	<p>Refer to the documentation for the motor.</p> <p>Comply with the monitoring intervals.</p> <p>The insulation resistance needs to be greater than 5 MOhm.</p> <p>Provide a time-delay residual current device.</p> <p>Provide overload protection by means of a motor protection switch or an equivalent protective device.</p> <p>Observe the minimum spacing between the air inlet on the fan hood and any obstacles.</p> <p>Avoid deposits of dust more than 5 mm deep.</p> <p>Connect the earth wire.</p> <p>Max. installation height: 1,000 m.a.s.l.</p>
Ignition hazard with bought-in actuator or control drive components	<p>Refer to the documentation for the actuator.</p> <p>Wait 3 minutes after switching off before opening the housing.</p>
Ignition hazard caused by bought-in proximity switch NJ1.5-8GM-N (stroke sensor)	<p>Refer to the documentation for the proximity switch (electrical installation, maintenance, ...).</p>

Safety information



WARNING!

ATEX pumps in areas at risk from explosion

- The operator must observe the Operator Directive when operating equipment in areas at risk of explosion.
- Only clean plastic parts carefully with a damp cloth to avoid electrostatic charges and sparks.



WARNING!

Motor may overheat

If the necessary cooling air supply is not guaranteed, the motor may overheat. In an area at risk from explosion, it could trigger an explosion.

- Maintain sufficient clearance between the air intake opening and the walls. The distance should be greater than 1/4 of the diameter of the air intake opening.
- The fan must not suck in the exhaust air from other devices.



WARNING!

ATEX pumps in areas at risk from explosion

- Metering pumps must have an appropriate safety relief valve on the discharge side (to protect against excessive heating due to overloading or impact sparks caused by the breakage of power end parts).



WARNING!

ATEX pump and flammable media

The ignition temperature is reduced significantly below the ignition temperature at atmospheric pressure due to compression with the discharge stroke of the possibly ignitable vapour-air mixture.

- Only use pumps with electrically conductive dosing heads.
- Do not allow it to run dry. Take appropriate safety measures – for instance, install a flow meter.
- The customer must wire a diaphragm rupture indicator or flow meter to ensure that it immediately stops the pump.



WARNING!

ATEX pumps in areas at risk from explosion

If feed chemicals are metered, which tend to produce exothermic reactions or self-ignite (examples of exothermic reactions: pyrophoric substances with air, alkali metal with water, decomposition of organic peroxides, polymerisation reactions), they can lead to high temperatures and ignition.

- Put in place measures in accordance with EN 80079-38.



WARNING!

ATEX pumps in areas at risk from explosion

If abrasive media is being metered, it will escape as soon as all layers of the diaphragm have eroded through.

- Wire the electrical diaphragm rupture indicator to immediately stop the pump in the event of a diaphragm rupture.



WARNING!

ATEX pumps in areas at risk from explosion

- Electrically wire all electrical assemblies cleanly and permanently to an electrically clean earthing point, - e.g. with an earthing bar on your system.
- Electrically connect the assemblies fitted with a potential equalisation cable to each other, cleanly and permanently, to an electrically clean potential equalisation point - e.g. with a potential equalisation bar on your system.
- Note the documentation supplied for the individual electrical components.



WARNING!

ATEX pumps in areas at risk from explosion

- Use a suitable motor protection switch to protect power end motors. Use motor protection approved for this application with Ex"e" motors. (Protection against warming caused by overloading)
- Provide a time-delayed residual current safety device.
- Observe the enclosed operating instructions for the Ex motor.

**WARNING!****The following applies in areas at risk from explosion:**

- Note the details of the type examination certificate PTB 00 ATEX 2048 X for the Namur sensor NJ1.5-8GM-N as well.

**WARNING!****ATEX pumps in areas at risk from explosion**

- Make sure that a suitably competent person checks whether the appropriate installation information from the "Installation" chapter has been implemented correctly.
- Make sure that a "recognised competent person" checks the electrical installation and in particular the intrinsically safe power circuits.
- Set the opening pressure of the relief valve to a maximum of no more than 1.5 times the nominal pressure of the pump.

**WARNING!****ATEX pumps in areas at risk from explosion**

- Carry out a general check to ensure that the system is working properly, particularly the power end and bearings, by regular monitoring (for leaks, noises, temperatures, smell ...).
- Do not allow the pump to run hot due to a lack of oil. With lubricated metering pumps, regularly check for the presence of lubricant, for example by checking the liquid level, visual leak control etc. If oil is leaking, examine the leakage point immediately and eliminate the cause.
- Check the correct operation of the relief valve downstream of the pump. In premises at risk from explosion, the relief valve should prevent the gear from becoming overloaded and becoming hot.
- Observe the enclosed operating instructions for the Ex motor.
- Only use a moist cloth when cleaning plastic parts.
- Prevent serious deposits of dust on the motor.
- Consider potential equalisation before you approach any pump equipment that could be at a different electrical potential (such as pipes or tools).
- Replace wear parts, such as bearings, when there is an identifiable incidence of unacceptable wear.
- Appropriate diagnostic equipment for bearing damage is recommended for the premature detection of bearing damage.
- Check whether the potential equalisation lines are all sitting correctly with clean contacts. Use the equipotential bonding drawings as an aid – see Appendix.
- Check whether the earth lines are all sitting correctly with clean contacts. Use the equipotential bonding drawings as an aid – see Appendix.
- Only use genuine spare parts as replacements.

2.7.4 Potential equalisation lines and other features

Potential equalisation lines (required in areas at risk from explosion)

The entire installation supplied is provided ex works with the necessary potential equalisation lines.

Electrically wire an additional potential equalisation cable from this system of potential equalisation lines cleanly and permanently to an electrically clean potential equalisation point, e.g. to a potential equalisation bar on site.

Namur sensor (Specified for EX zones)

5–25 V DC, in accordance with Namur or DIN 60947-5-6, potential-free design.

Specification	Value
Nominal voltage *	8 V DC
Power consumption - active surface uncovered	> 3 mA
Power consumption - active surface covered	< 1 mA
Rated switching distance	1.5 mm

* Ri ~ 1 kΩ

Cable colour	Polarity
blue	-
brown	+

Install the sensor in accordance with the chapter "Installation, electrical". Refer to its documentation.

Sensor name: NJ1.5-8GM-N.

Inspection, daily

Check the pump installation for:

- leaks
- Abnormal noises or squeaks
- abnormal temperatures
- abnormal odours
- abnormal vibrations
- other anomalies



WARNING!

Stop the pump immediately in the event of any anomalies when inspecting the pump and rectify them immediately. ProMinent Service may be needed if required.

2.7.5 ATEX features

Maintenance

Interval	Maintenance work
After 18,000 operating hours or 23,500 operating hours (API)	Adhere to the motor manufacturer's recommendations - see operating instructions for the motor.

➔ Screw in the oil drainage plug (2) with a new seal.



WARNING!

Check after 1 day whether the oil drainage plug (2) is still tight.

Power end and motor - ATEX

Data	Value	Unit
Ambient temperature during operation:	-10 ... +40	°C

TTT - ATEX liquid end

Data	Value	Unit
Max. temperature, long-term at max. operating pressure	50	°C
Minimum temperature.	-10	°C

SST - ATEX liquid end

Data	Value	Unit
Max. temperature, long-term at max. operating pressure	90	°C
Minimum temperature.	-10	°C

Installation height

Data	Value	Unit
Maximum installation height*:	1000	m a.s.l.

* We urgently advise you to contact a specialist for ATEX motors with higher installation heights!

2.7.6 Safety equipment

Other safety equipment - ATEX labels



WARNING!

- The following safety information must be affixed to pumps that include parts made of electrically non-conducting plastic.
- Ensure that the label is always fitted and legible.
- Do not allow other labels to be stuck over this label.

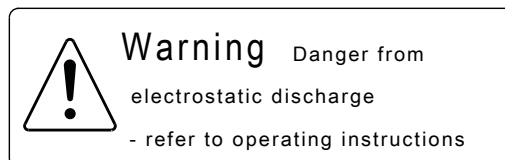

Fig. 2

Requirements if the motor is being installed independently

The operator must be able to:

- With ATEX motors: perform an ignition hazard assessment

Assembly of the motor - with designs without motor



WARNING!

The following instructions relevant in areas at risk from explosion apply in areas at risk from explosion.

1. ➤ Select a suitable motor - the motor must correspond to the data for one of the motors from the "Motor data" table - see "Technical data" chapter.
2. ➤ Have technical personnel fit the motor correctly on the flange.
Observe the coupling operating instructions!
With a claw coupling: Fix the claw on the motor shaft at the correct height – see corresponding figure and table.
3. ➤ Attach the documentation / operating instructions for the motor with the documentation for the pump.

Special conditions with "X"

If there is an "X" at the end of the ATEX specification of an assembly in a "Declaration of Conformity for ATEX machines" or a "Declaration of Incorporation for ATEX machines", then special conditions apply for the safe operation of the equipment in areas at risk from explosion.

Please refer in this respect to the operating instructions, design test certificates and other documentation for the bought-in parts!

2.8 Explanation of the ATEX label

in accordance with Directive 2014/34/EU and standards EN ISO 80079-36, -37

Explanation of the pump's ATEX labelling Sigma/ 2

Unit group	
II	No mines or associated underground systems, which can be endangered by firedamp - Unit for use in other areas at risk from explosion
Other parameters	
3G Ex h	(Example)
Explosion group	
IIC	for explosion group IIC gas - refer to your explosion protection document
IIB	for explosion group IIB gas - refer to your explosion protection document
Temperature class	
T3	for Temperature class T3 gas - refer to your explosion protection document
T4	for Temperature class T4 gas - refer to your explosion protection document
Equipment protection level (EPL)	
Gb	high EPL use possible in zones 1 and 2 - refer to your explosion protection document

Explanation of the pump's ATEX labelling Sigma/ 2

					Gc	normal EPL use possible in zone 2 - refer to your explosion protection document
					Suffix X	
					X	Special conditions - refer to the Declarations of Conformity and EC-type examination certificates



WARNING!

Example of EX-designation: Where may I use the ATEX version of the Sigma/ 2?

The pump designation is:

" ... II 3G Ex h IIB T4 Gc".

The pump label corresponds to "Unit group" II: the pump may only be used in overground production systems, which are not at risk from firedamp.

The inserted pump label "3G Ex h" does not need to be discussed here.

The additional pump label in the example states "Explosion group" IIB and "Temperature class" T4:

The  *Tab. 2 'Example of the division of gases into explosion groups and temperature classes' on page 23* is shown as an example: the pump can be used for ethyl ether or a comparable gas - refer to the material safety data sheet for the gas or your explosion protection document.

The pump in the example could also be suitable for gases that require only "Explosion group" IIA and "Temperature class" T3, T2 or T1 - but not for T5 and T6.

"EPL" Gc is shown in the next example: Use only in zone 2 – but not in zone 1 or zone 0.

Tab. 2: Example of the division of gases into explosion groups and temperature classes

	T6 85 °C	T5 100 °C	T4 135 °C	T3 200 °C	T2 300 °C	T1 450 °C
IIC	Carbon disulphide	-	Trichlorosilane	-	Ethyne	Hydrogen
IIB	-	-	Ethyl ether	-	Ethene	Mains gas (coal gas)
IIA	-	-	Acetaldehyde	Benzine, Diesel fuel, Aircraft fuel, Heating oils, n-hexane	Ethanol, n-butane, n-butyl alcohol	Acetone, Ammonia, Benzene (pure), Acetic acid, Ethane, Ethyl acetate, Carbon oxide, Methanol, Propane, Toluene



WARNING!

Example 2 - EX-designation: Where may I use the ATEX version of the Sigma/ 2?

The pump designation is " ... II 2G Ex h IIC T4 Gb X".

The pump label corresponds to "Unit group" II: the pump may only be used in overground production systems, which are not at risk from firedamp.

The inserted pump label "2G Ex h" does not need to be discussed here.

The pump label is shown in the example "Explosion group" IIC and "Temperature class" T4:

The ↗ *Tab. 2 'Example of the division of gases into explosion groups and temperature classes' on page 23* shows the following: the pump can be used for all gases of "Explosion group" IIC and "Temperature class" T4 - refer to your explosion protection document.

The pump in the example could also be suitable for gases that require only "Explosion group" IIB or IIA and "Temperature class" T3, T2 or T1 – but not for T5 and T6.

"EPL" Gb is shown in the next example: use is possible in zone 1 and zone 2 – but not in zone 0.

"X" indicates "Special conditions" - see EU Declaration of Conformity or type test certification for the pump or additional assemblies. This might involve another lower limit for the ambient temperature, e.g. -10 °C .

3 Storage, transport and unpacking

Safety information



WARNING!

Only return the metering pump for repair in a cleaned state and with a flushed liquid end - refer to the chapter "Decommissioning"!

Only return metering pumps with a completed Decontamination Declaration form. The Decontamination Declaration constitutes an integral part of an inspection / repair order. A unit can only be inspected or repaired when a Declaration of Decontamination Form is submitted that has been completed correctly and in full by an authorised and qualified person on behalf of the pump operator.

The "Decontamination Declaration Form" can be found at www.prominent.com.



CAUTION!

Danger of material damage

The device can be damaged by incorrect or improper storage or transportation!

- The unit should only be stored or transported in a well packaged state - preferably in its original packaging.
- Only transport the unit when the red gear bleeding plug is pushed in.
- The packaged unit should also only be stored or transported in accordance with the stipulated storage conditions.
- The packaged unit should be protected from moisture and the ingress of chemicals.

Scope of delivery

Compare the delivery note with the scope of delivery.

Storage

Personnel: Technical personnel

1. Fit the caps to the valves.
2. Check if the red gear bleeding plug is pushed in.
3. Place the pump standing vertically on a pallet and secure against falling over.
4. Cover the pump with a tarpaulin cover, allowing for rear ventilation.

Store the pump in a dry, sealed room under the ambient conditions described in the Chapter "Technical Data".

4 Overview of equipment and control elements

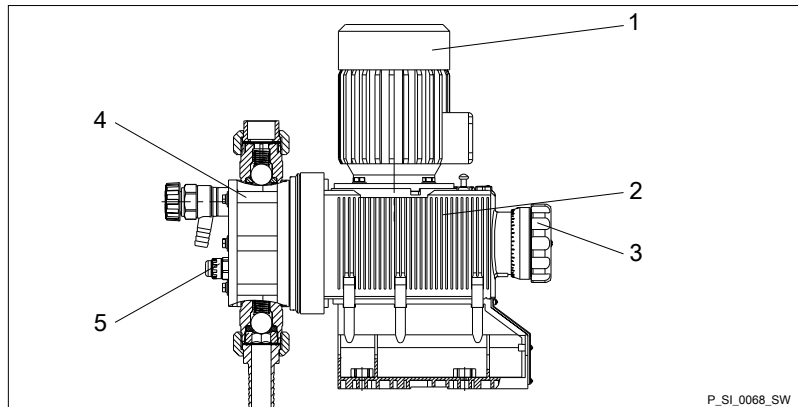

Fig. 3: Overview of equipment and control elements S2Ba

- 1 Drive motor
- 2 Drive unit
- 3 Stroke length adjustment knob
- 4 Liquid end with relief valve
- 5 Diaphragm rupture sensor

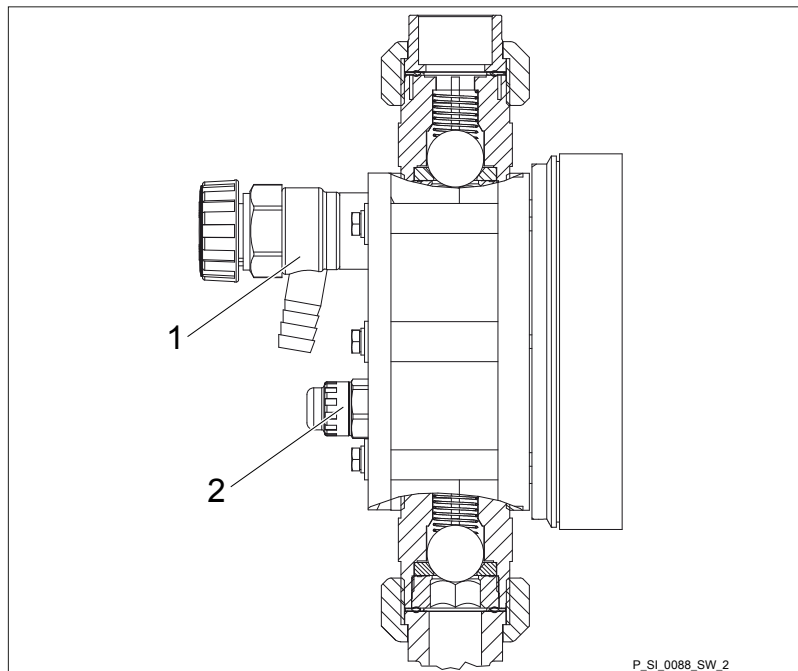

Fig. 4: Sigma control elements

- 1 Relief valve
- 2 Diaphragm rupture sensor (visual)

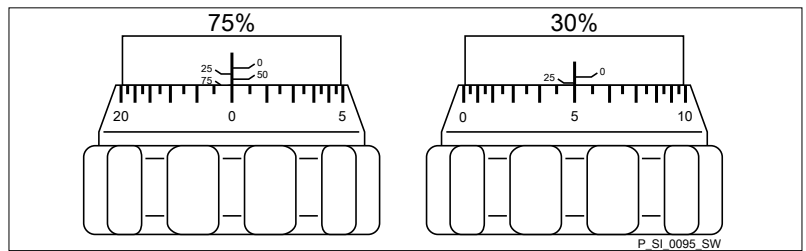

Fig. 5: Adjusting the stroke length

- 100% = 4 rotations
- 25 % = 1 rotation
- 0.5 % = 1 scale mark on stroke adjustment dial

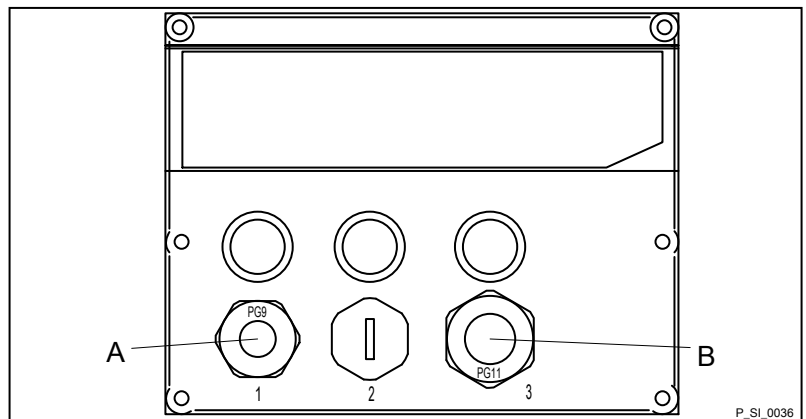

Fig. 6: Front cover for version with pacing relay

- A Pacing relay cable
- B Supply voltage cable for pacing relay PCB

5 Functional description

5.1 Pump

The metering pump is an oscillating diaphragm pump, the stroke length of which is adjustable. An electric motor drives the pump.

5.2 Liquid end

The diaphragm (2) hermetically shuts off the pump volume of the dosing head (4) towards the outside. The suction valve (1) closes as soon as the diaphragm (2) is moved in to the dosing head (4) and the feed chemical flows through the discharge valve (3) out of the dosing head. The discharge valve (3) closes as soon as the diaphragm (2) is moved in the opposite direction due to the vacuum pressure in the dosing head and fresh feed chemical flows through the suction valve (1) into the dosing head. One cycle is thus completed.

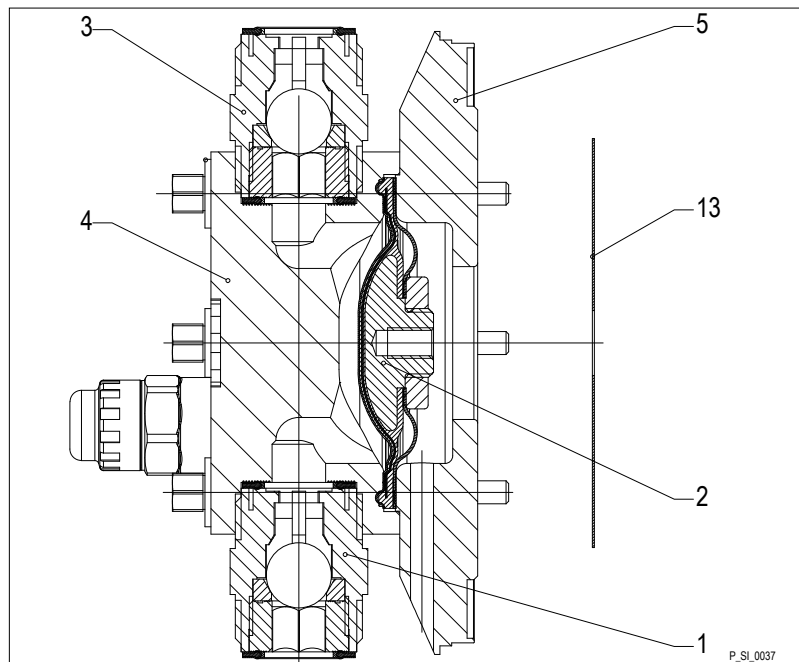

Fig. 7: Cross-section through the liquid end

- 1 Suction valve
- 2 Diaphragm
- 3 Discharge valve
- 4 Dosing head
- 5 Backplate
- 13 Safety diaphragm

5.3 Integral relief valve

The integral relief valve normally operates as a simple, directly controlled **bleeder valve**. The feed chemical then flows out through the hose connection, e.g. into a storage tank, as soon as the pressure exceeds the pre-set pressure value.

The integral relief valve can only protect the motor and the gear, and then only against impermissible positive pressure that is caused by the metering pump itself. It cannot protect the system against positive pressure.

The integral relief valve works as a **bleed valve** if the rotary dial is turned clockwise up to the "open" stop, acting as a priming aid when starting up the pump against pressure.

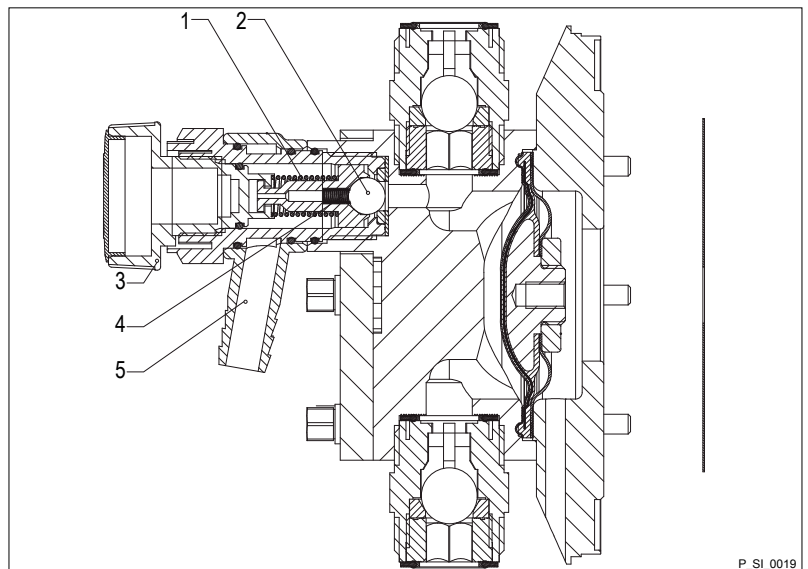

Fig. 8: Integral relief valve

- 1 Spring, large
- 2 Ball
- 3 Rotary dial
- 4 Spring, small
- 5 Hose connection

5.4 Multi-layer safety diaphragm

With **visual** diaphragm rupture sensors, in the event of a diaphragm rupture, the lowered red cylinder (6) springs forward beneath the transparent cover (7) so that it then becomes clearly visible - see Fig. 9.

With the **electrical** diaphragm rupture sensor, a switch is switched. A signalling device must be connected to signal the diaphragm rupture.

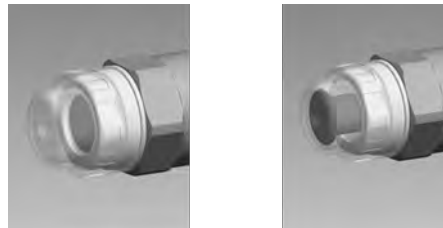

Fig. 9: Visual diaphragm rupture sensor, triggered and untriggered

6 Assembly

Compare the dimensions on the dimensional drawing with those of the pump.

6.1 Assembly of the motor - with designs without motor

1. ➤ Select a suitable motor. The motor must correspond to the data for one of the motors from the "Motor data" table - see Chapter "Technical Data".
2. ➤ Have qualified personnel fit the motor correctly on the flange!
Pay attention to the operating instructions for the coupling.
With a claw coupling: The claw on the motor shaft must be fixed at the correct height, see Fig. 10
3. ➤ Secure set screws and threaded connections to prevent them from loosening.
4. ➤ As you have converted an "incomplete machine" into a complete machine, you must perform a conformity assessment, risk assessment, issue an EC Declaration of Conformity, fit your own company nameplate, With ATEX pumps: additionally perform an ignition hazard assessment.
5. ➤ Complete the pump documentation / operating instructions.

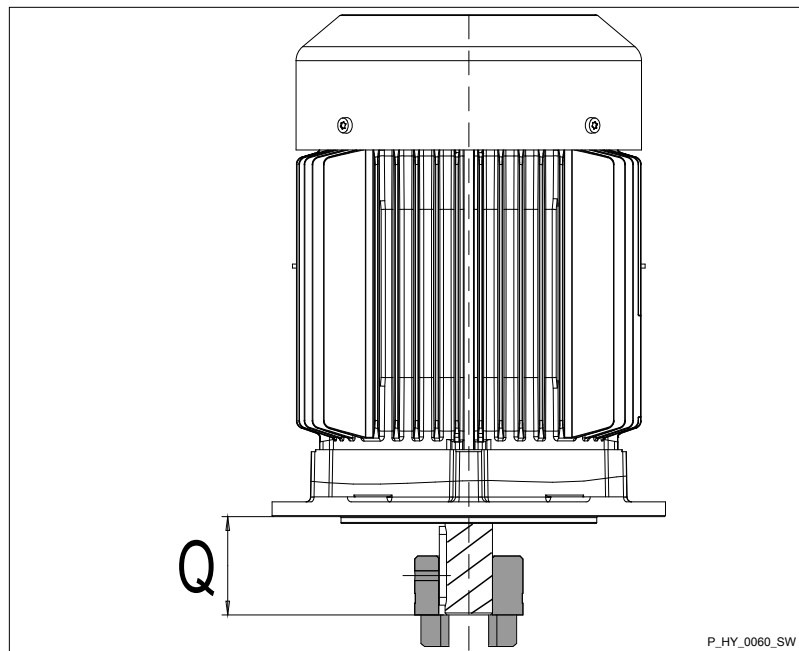

Fig. 10: Correct height of the coupling claw on the motor shaft

Tab. 3: Sigma

Model size	Motor flange	Q
71	B 14/105	29
-	56C/138	1.14"
71	B 14/105	29
80	B 14/105	52.5

Model size	Motor flange	Q
63	B 5/140 *	(26)

Dimensions in mm - unless otherwise indicated.

* Motor is fitted directly onto the motor flange without intermediate flange and claw coupling.

6.2 Base

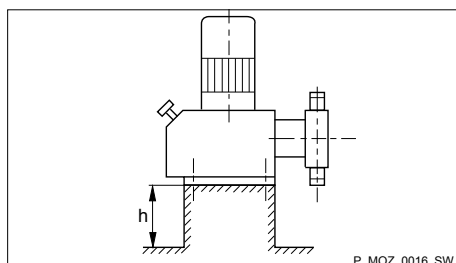

Fig. 11: Base

The pump can break through the base or slide off it

- Ensure that the base is horizontal, flat and permanently load-bearing.

Dosing rate too low

- Vibrations can disturb the valves of the liquid end.
- Do not allow the base to vibrate.

6.3 Space requirement

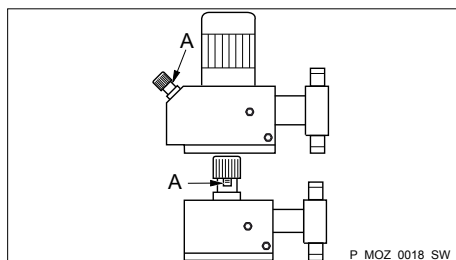

Fig. 12: Space requirement



WARNING! Motor may overheat

If the necessary cooling air supply is not guaranteed, the motor may overheat. In an area at risk from explosion, it could trigger an explosion.

- Maintain sufficient clearance between the air intake opening and the walls. The distance should be greater than 1/4 of the diameter of the air intake opening.
- The fan must not suck in the exhaust air from other devices.



CAUTION! Danger from incorrectly operated or inadequately maintained pumps

Danger can arise from a poorly accessible pump due to incorrect operation and poor maintenance.

- Ensure that the pump is accessible at all times.
- Adhere to the maintenance intervals.

Position the pump so that control elements, such as the stroke length adjustment knob or the indicating dial A, are easily accessible.

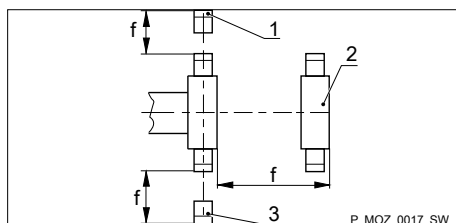

Fig. 13: Clearance (f)

- 1 Discharge valve
- 2 Dosing head
- 3 Suction valve

Ensure there is sufficient clearance (f) around the dosing head as well as the suction and discharge valve so that maintenance and repair work can be carried out on these components.

Liquid end alignment

Dosing rate too low

- The valves of the liquid end cannot close correctly if the valves of the liquid end are not upright.
- Ensure that the discharge valve is upright.

6.4 Fastening

Liquid end alignment

Dosing rate too low.

The valves of the liquid end cannot close correctly if the valves of the liquid end are not upright.

- Ensure that the discharge valve is upright.

Vibrations can disturb the liquid end valves.

- Secure the metering pump so that no vibrations can occur.

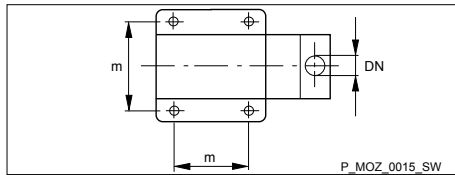

Take the dimensions (m) for the fastening holes from the appropriate dimensional or data sheets.

Use appropriate screws to fix the pump base to the foundation.

Fig. 14: Dimensions (m)

7 Installation, hydraulic

Disregarding the technical data during installation can lead to personal injury or damage to property.

- Observe the technical data - refer to the Chapter "Technical data" and, where applicable, the operating instructions for the accessories.



WARNING!

ATEX pumps in areas at risk from explosion

- Metering pumps must have an appropriate safety relief valve on the discharge side in order to protect against excessive heating due to overloading or impact sparks caused by the breakage of power end parts.

Flammable feed chemicals

- Pumps with the identity code option "Multi-layer safety diaphragm with rupture signalling (contact)" are only approved for use with flammable feed chemicals with electrically conductive dosing heads, at back pressures of over 2 bar and only if the operator takes appropriate safety measures.
- Rupture signalling or, possibly, a flow control fitted on the discharge side must stop the pump safely and as quickly as possible as soon as there is a diaphragm rupture or, for instance, in the event that there is no flow.
- Do not allow it to run dry.
- It is the responsibility of the operator to implement further measures if necessary.



WARNING!

Warning of feed chemical reactions to water

Feed chemicals that should not come into contact with water may react to residual water in the liquid end that may originate from works testing.

- Blow the liquid end dry with compressed air through the suction connector.
- Then flush the liquid end with a suitable medium through the suction connector.



WARNING!

The following measures are an advantage when working with highly aggressive or hazardous feed chemicals:

- Install a bleed valve with recirculation in the storage tank.
- Install an additional shut-off valve on the discharge or suction ends.

PTFE seals

- PTFE seals, which have already been used / compressed, can no longer reliably seal a hydraulic connection.
- Always use new and unused PTFE seals.

Possible suction problems

- The valves may no longer close properly with feed chemicals with particles larger than 0.3 mm.
- Install an appropriate filter in the suction line.

Rupture of the pressure line

- With a closed pressure line (e.g. due to a clogged pressure line or by closing a valve), the pressure that the metering pump generates can reach several times the permissible pressure of the system or the metering pump. This could lead to lines bursting resulting in dangerous consequences with aggressive or toxic feed chemicals.
- Install a relief valve that limits the pressure of the pump to the maximum permissible operating pressure of the system.

Uncontrolled flow of feed chemical

- Feed chemical may press through a stopped metering pump if there is back pressure.
- Use an injection valve or a vacuum breaker.

Uncontrolled flow of feed chemical

- Feed chemical may press through the metering pump in an uncontrolled manner in the event of excessive priming pressure on the suction side of the metering pump.
- Do not exceed the maximum permissible priming pressure for the metering pump or
- Set up the installation properly for this.

Warning of leaks

- Leaks can occur at the pump connector depending on the insert used.
- The pump is supplied with PTFE moulded composite seals with a flare, which are used for the pump connectors, and which seal the connectors between grooved pump valves and ProMinent grooved inserts - see Fig. 15.
- Use an elastomer flat seal in the event that an unflared insert is used (e.g. third party part) - see Fig. 16.

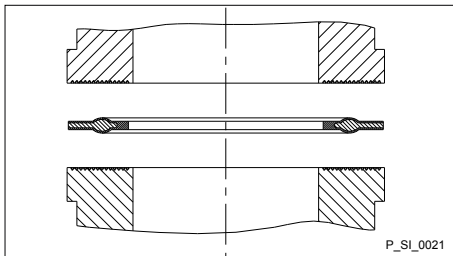

Fig. 15: Moulded composite seals with grooved insert

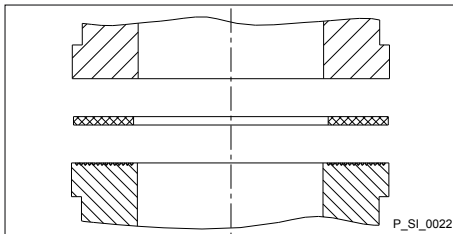

Fig. 16: Elastomer flat seal with a smooth insert

Warning of backflow

- Liquid ends, foot valves, back pressure valves, relief valves or spring-loaded injection valves do not constitute fully leak-tight sealing elements.
- Use a shut-off valve, a solenoid valve or a vacuum breaker for this purpose.

Integral relief valve



WARNING!

Product can be dangerously contaminated

Only with "Physiologically safety with regard to wetted materials" version:

- The feed chemical will come into contact with seals that are not physiologically safe if the integral vent valve or the integral relief valve opens.
- Do not route feed chemical that escapes from the integral bleed valve or the integral relief valve back into the process.

**CAUTION!****Danger due to incorrect use of the integral relief valve**

The integral relief valve can only protect the motor and the gear, and then only against impermissible positive pressure that is caused by the metering pump itself. It cannot protect the system against positive pressure.

- Protect the motor and gear of the system against positive pressure using other mechanisms.
- Protect the system against illegal positive pressure using other mechanisms.

Warning of feed chemical spraying around

- If no relief valve has been connected to the overflow line, the feed chemical then sprays out of the hose connection as soon as the relief valve opens.
- An overflow line must always be connected to the integral relief valve and be fed back to the supply tank or - if required by the regulations - into a special tank.

Crack formation

- Cracks on the PVT liquid end can occur if a metal overflow line is connected to the relief valve.
- Never connect a metal overflow line to the relief valve.

Failure of the integral relief valve

- The integral relief valve no longer operates reliably with feed chemicals that have a viscosity of greater than 200 mPa s.
- Only use the integral relief valve with feed chemicals that have a viscosity of up to 200 mPa s.

Leaks

- Feed chemical which remains in the overflow line at the relief valve can attack the valve or cause it to leak.
- Route the overflow line with a continuous slope and moreover with the hose sleeve pointed downwards - see Fig. 17.

The bleed function is blocked if the overflow line is fed into the suction line. Therefore lead the overflow line back into the supply tank.

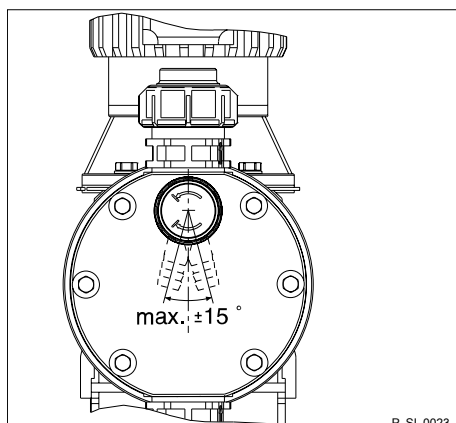

Fig. 17: Permissible alignment of the relief valve



When operating the integral relief valve close to the opening pressure, a minimal overflow into the overflow line can occur.

Diaphragm rupture sensor**Unnoticed diaphragm rupture**

- If the pump has been ordered with an electric diaphragm rupture sensor, then the diaphragm rupture sensor must also be installed.
- Screw the enclosed diaphragm rupture sensor into the liquid end.

Unnoticed diaphragm rupture

- From approx. 2 bar back pressure, the system will emit a signal in the event of a diaphragm rupture.
- You should only rely on the diaphragm rupture sensor for back pressures over 2 bar, or install a back pressure valve and set it to a minimum of 2 bar, if the installation permits this.

7.1 Basic installation notes

Safety information

Rupturing hydraulic components

- Hydraulic components can rupture if the maximum permissible operating pressure of the hydraulic parts is exceeded.
- Never allow the metering pump to run against a closed shut-off device.
- With metering pumps without integral relief valve: Install a relief valve in the pressure line.

Hazardous feed chemicals can escape

- With hazardous feed chemicals: Hazardous feed chemical can leak out when using conventional bleeding procedures with metering pumps.
 - Install a degassing line with a return line into the supply tank.
- ➔ Shorten the return line so that the line is not immersed in the feed chemical in the supply tank.

Standard installation

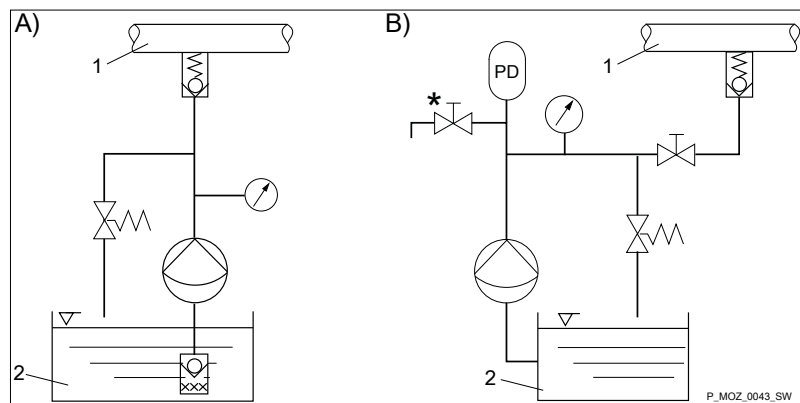

Fig. 18: (A) Standard installation, (B) with pulsation damper

- 1 Main line
- 2 Supply tank

Tab. 4: Legend for hydraulic diagram

Symbol	Explanation	Symbol	Explanation
	Metering pump		Foot valve with filter mesh
	Injection valve		Level switch
	Back pressure valve or safety valve		Manometer

8 Installation, electrical

Danger of injury to personnel and material damage

- Disregarding the technical data during installation can lead to personal injury or damage to property.
- Observe the technical data - refer to the Chapter "Technical data" and, where applicable, the operating instructions for the accessories.



WARNING!

Danger of electric shock

In the event of an electrical accident, it must be possible to quickly disconnect the pump, and any electrical ancillaries which may possibly be present, from the mains.

- Install an emergency cut-off switch in the mains supply line to the pump and any electrical ancillaries which may be present or
- Integrate the pump and electrical ancillaries which may be present in the emergency cut-off management of the system and inform personnel of the isolating option.

ATEX pumps in areas at risk from explosion

- Electrically connect the electrical assemblies listed on the earthing diagram in the appendix, cleanly and permanently, to an electrically clean earthing point, e.g. with an earthing bar on your system.
- Electrically connect the assemblies fitted with a potential equalisation cable to each other, cleanly and permanently, to an electrically clean potential equalisation point, e.g. with a potential equalisation bar on your system.
- Note the documentation supplied for the individual electrical components.

Risk of fire with flammable feed chemicals

- An ATEX diaphragm rupture sensor or, possibly, a flow control fitted on the discharge side, must stop the pump safely and as quickly as possible as soon as there is a diaphragm rupture or, for instance, in the event that there is no flow.

Danger of electric shock

- Improper installation can lead to electric shocks.
- Crimp cable end sleeves onto all stripped cable cores.
- Make sure that only technically trained personnel are authorised to undertake the electrical installation of the unit.



WARNING!

Danger of electric shock

- There can still be dangerous voltage present for 3 minutes in the interior of motor designs with integral frequency converter.
- Only open the drain screw 3 minutes after the mains voltage has been switched off.

Never change the "Motor voltage" and "Cycle frequency" parameters with motor designs with integral frequency converter.

The parameters on delivery from ProMinent do not correspond to the motor manufacturer's factory settings.

If other parameters are to be changed, then we recommend speaking to ProMinent head office in Heidelberg.

What requires electrical installation?:

- Motor
- External fan (optional)
- Stroke control drive (optional)
- Stroke adjusting drive (optional)
- Diaphragm rupture sensor (optional)
- Stroke sensor (optional)
- Pacing relay (option)
- Frequency converter (optional)
- Earthing wires (to be provided on site)
- Potential equalisation line (to be provided on site, prescribed in the area at risk from explosion)

Motor

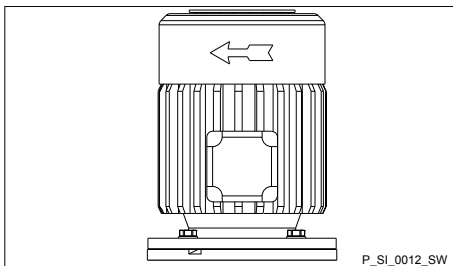

Fig. 19: Direction of rotation of motor

ATEX pumps in areas at risk from explosion

- Use a suitable motor protection switch to protect power end motors. Use motor protection approved for this application with Ex"e" motors. (Protection against warming caused by overloading)
- Ensure that motors are only installed and checked in areas at risk from explosion by a "recognised competent" person.
- Observe the enclosed operating instructions for the Ex motor.

The motor can be damaged

- Provide appropriate motor protection devices to protect the motor against overloading (e.g. motor protection switch with thermal overcurrent trip).
- Fuses do not provide motor protection.

Operation of the system can be disrupted

- If a motor protection switch is used, operation of the system can then be disrupted by an inappropriate setting.
- Set the response threshold of the motor protection switch to approx. 1.4 ... 1.5 times the nominal current of the motor (motor nameplate) (due to pulsing load).

This does not lead to the motor being overloaded.

Only motors with a frequency converter: The motor can be damaged

- The input current limiter could be damaged if a motor with integrated frequency converter is restarted within 3 minutes of the mains voltage being switched off.
- After switching off, allow the unit to stand for at least 3 minutes before restarting.
- If the motor is controlled by a control, take this into consideration on the control.

Pump can be damaged

- The pump can be damaged if the motor drives the pump in the wrong direction.
- When connecting the motor, pay attention to the correct direction of rotation, indicated by the arrow on the fan cover, as shown in Fig. 19.

Use an electrical isolating device in the mains supply cable, such as a mains switch, to de-energise the pump independently of the entire installation (e.g. for repairs).

1. ➤ Install a motor protection switch, as the motors have no fuse.
2. ➤ Install an emergency cut-off switch or include the motor in the system's emergency cut-off management scheme.
3. ➤ Only connect the motor to the power supply using a suitable cable.

Motor data/Terminal diagram

- Key motor data can be found on the nameplate and in the "Technical data" chapter.
- The terminal wiring diagram is located in the terminal box.



Motor data sheets, special motors, special motor flanges, external fan, temperature monitoring

- For further information on the motor with identity code specification "S", refer to our website www.prominent.com. Motor data sheets can be requested for all other motors.
- With motors other than those with identity code specifications "S", "M" or "N": Pay special attention to the operating instructions for the motors.
- Special motors or special motor flanges are available on request.

External fan

Provide a separate power supply for the external fan for motors with external fans (identity code specification "R" or "Z").

Variable speed motors with frequency converter

Connect the motor as per the wiring diagram for the controller if it is controlled by an electronic control unit (such as 3-phase AC motors by frequency converter).

Stroke length actuators / control power ends

Connect the motors in accordance with the enclosed wiring diagram or as per the wiring diagram fixed to the inside of the housing.

Only operate stroke length actuators / control drives when the pump is running. Otherwise they will be damaged.

Diaphragm rupture sensor (optional)

Protective low voltage

- In the event of a fault, there is a danger of electric shock if conductive feed chemicals are present.
- For safety reasons, we recommend connecting to protective low voltage, e.g. in accordance with EN 60335-1 (SELV).

Danger resulting from unnoticed diaphragm rupture

- If the pump has been ordered with an electric diaphragm rupture sensor, it must also be electrically installed.
- Electrically wire the enclosed diaphragm rupture sensor to a suitable monitoring device.

a) Diaphragm rupture sensor with switch contact

The cable can be connected as required.

b) Namur sensor, inherently safe

Make sure that the monitoring/feed equipment installed by the customer is capable of evaluating the current variations of the Namur sensor to indicate a diaphragm rupture.

The following applies in areas at risk from explosion:

- Note the details of the type examination certificate PTB 00 ATEX 2048 X for the Namur sensor NJ1.5-8GM-N as well.

Stroke sensor (identity code specification "Stroke sensor": 3)

➔ Connect the stroke sensor to a suitable monitoring device according to the technical data provided with the monitoring device and that of the stroke sensor - see chapter "Technical data".

Make sure that the monitoring/feed equipment installed by the customer is capable of evaluating the current variations of the Namur sensor to indicate a stroke.

The following applies in areas at risk from explosion:

- Note the details of the type examination certificate PTB 00 ATEX 2048 X for the Namur sensor NJ1.5-8GM-N as well.

Pacing relay (identity code specification "Stroke sensor": 2)

1. ➔ Install the cable which originates from the pacing relay - see the figure in the chapter entitled "Overview of equipment and control elements": Cable A, left.

The cable polarity is unimportant.

2. ➔ Install the power supply cable to the pacing relay PCB - see the figure in the chapter entitled "Overview of equipment and control elements": Cable B, right.

Overloading

- If the current through the relay becomes too high, it can be destroyed by heating.
- Fit a circuit breaker.

Pacing relay terminal output data

Data	Value	Unit
Maximum voltage	24	V DC
Maximum current	100	mA
Closing duration, approx.	100	ms
Service life *	50 x 10 ⁶ (10 V, 10 mA)	Play

* at rated load

The contacts are potential-free.

The pacing relay is N/O as standard.

Tab. 5: Supply voltage for pacing relay PCB

Available supply voltages	Mains frequency	Power consumption
230 V AC (180-254 V)	50 / 60 Hz	10 mA (at 230 V, 50 Hz)
115 V AC (90-134 V)	50 / 60 Hz	15 mA (at 115 V, 60 Hz)
24 V DC (20-28 V)	-	10 mA (at 24 V DC)

Heating cartridge

➔ Install the heating cartridge in line with its documentation. The heating cartridge must only be connected to the power device supplied!

Earthing lines

Connect the electrical components of the entire installation supplied cleanly and permanently to an electrically clean earthing point, e.g. with an earthing bar on site - see earthing diagrams in the appendix.

Potential equalisation lines, required in areas at risk from explosion

The entire installation supplied is provided ex works with the necessary potential equalisation lines. Electrically wire an additional potential equalisation cable from this system of potential equalisation lines cleanly and permanently to an electrically clean potential equalisation point, e.g. to a potential equalisation bar on site.

Other assemblies

➔ Install the other assemblies in line with their documentation.

9 Start up

Safety information



WARNING!

ATEX pumps in areas at risk from explosion

- Make sure that a suitably competent person checks whether the appropriate installation information from the "Installation" chapter has been implemented correctly.
- Make sure that a "recognised competent person" checks the electrical installation and in particular the intrinsically safe power circuits.
- Set the opening pressure of the relief valve to a maximum of no more than 1.5 times the nominal pressure of the pump.



WARNING!

Only motors with a frequency converter: Danger of electric shocks

- The danger of an electric shock remains for 3 minutes after the mains voltage has been switched off on conducting parts of the motor with integrated frequency converter (FC) and on the lines themselves.
- After switching off, allow the unit to stand for 3 minutes before opening the terminal box.

Only motors with a frequency converter: The motor can be damaged

- The input current limiter could be damaged if a motor with integrated frequency converter is restarted within 3 minutes of the mains voltage being switched off.
- After switching off, allow the unit to stand for at least 3 minutes before restarting.

The metering pump may only be operated by trained personnel. The operator is responsible for ensuring that under the given operating conditions (pressure, temperature, corrosiveness, etc.) danger to the operating personnel is avoided by use of appropriate accident prevention measures.

Feed chemical could escape

- Check suction and pressure lines, and liquid end with valves, for leak-tightness and tighten if necessary.
- Check whether the necessary flushing pipes or bleed lines have been connected.

Liquid end may be damaged

- Always fit a filter in the suction line with feed chemicals with a particle size greater than 0.3 mm

Prior to commissioning, check that the power end motor or pump and corresponding ancillary equipment is connected in compliance with the regulations.

When using pumps with speed control, observe the instructions in the frequency converter operating instructions.

Pay attention to the technical data

Observe the details in the Chapter "Technical data", such as pressure, viscosity, resistance, etc.

Checking for regulation-compliant installation

Diaphragm rupture sensor

Unnoticed diaphragm rupture

- If the pump has been ordered with an electric diaphragm rupture sensor, then the diaphragm rupture sensor must also be installed.
- Screw the enclosed diaphragm rupture sensor into the liquid end.

Unnoticed diaphragm rupture

- From approx. 2 bar back pressure, the system will emit a signal in the event of a diaphragm rupture.
- You should only rely on the diaphragm rupture sensor for back pressures over 2 bar, or install a back pressure valve and set it to a minimum of 2 bar, if the installation permits this.

**CAUTION!****Possible environmental and material damage**

In event the red gear bleeding plug is sealed, during operation it prevents any pressure compensation between the drive housing and the surroundings. This ensure that oil can be pushed from the drive housing.

- Remove the gear bleeding plug before commissioning.

Remove the gearbox vent stopper

Before start up, remove the red gearbox vent stopper, see "Overview of equipment and control elements" chapter.

Checking the oil level

When the pump is idle, check whether the oil level in the pump is in the middle of the oil level indicator.

This will rule out the pump losing oil and suffering damage.

Avoid particles

- The valves may no longer close properly with feed chemicals with a particle size of greater than 0.3 mm.
- Install an appropriate filter in the suction line.

Checking the direction of rotation

When commissioning the unit, check whether the drive motor is rotating correctly - check this against the arrow on the motor housing or the diagram in the chapter entitled "Electrical Installation."

**WARNING!****Risk of injury from the fan impeller**

The fan impeller beneath motor's fan cowling can cause severe injuries while it is turning.

- The pump must only be connected to the mains voltage with the fan cowling closed.

Using the integral relief valve



CAUTION!

Danger due to incorrect use of the integral relief valve

The integral relief valve can only protect the motor and the gear, and then only against impermissible positive pressure that is caused by the metering pump itself. It cannot protect the system against positive pressure.

- Protect the motor and gear of the system against positive pressure using other mechanisms.
- Protect the system against illegal positive pressure using other mechanisms.

Failure of the integral relief valve

- The integral relief valve no longer operates reliably with feed chemicals that have a viscosity of greater than 200 mPa s.
- Only use the integral relief valve with feed chemicals that have a viscosity of up to 200 mPa s.

Priming against pressure

1. ➤ Hydraulically isolate the pressure line from the pump using an isolation device.
2. ➤ Turn the rotary dial on the integral relief valve in a counter-clockwise direction as far as the "open" stop.
 - ⇒ The excess pressure escapes through the hose connector.
3. ➤ Run the pump until the feed chemical coming out of the hose connector is free from bubbles.
4. ➤ Turn the rotary dial on the integral relief valve in a clockwise direction up to the "close" stop.
 - ⇒ The pump can be started.



When operating the integral relief valve close to the opening pressure, a minimal overflow into the overflow line can occur.

Adjusting the stroke length

Only adjust the stroke length when the pump is running. This is easier and also better for the pump.

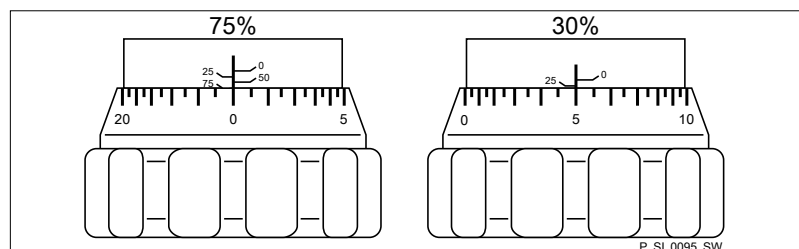

Fig. 20: Adjusting the stroke length

- 100% = 4 rotations
- 25% = 1 rotation
- 0.5% = 1 scale mark on stroke adjustment dial

Earthing lines

Check whether the earthing lines in the pump's electrical assemblies are correctly connected and connected to a clean earth wire - see earthing diagrams in the appendix.

Potential equalisation lines (mandatory with ATEX)

Check whether the potential equalisation lines are sitting correctly on the pump and connected to a clean potential equalisation point.

Auxiliary equipment

Check for the correct function of the auxiliary equipment and for correct interplay.

10 During operation



WARNING!

Personnel injury and material damage may occur

During use all units, protective equipment, additional devices must be fitted, operational and tightly closed.



WARNING!

Sparking caused by dry running

If the bearings in the power end run dry, sparks can be formed.

- Check for oil leaks.
- When the pump is idle, the pump oil level must slightly cover the lower oil inspection window.

Observe the instructions in the "Start up" chapter and the operating instructions for the other machine components.

11 Maintenance

11.1 Safety information

ATEX pumps in areas at risk from explosion

- Carry out a general check to ensure that the system is working properly, particularly the power end and bearings, by regular monitoring (for leaks, noises, temperatures, smell ...).
- Do not allow the pump to run hot due to a lack of oil.
With lubricated metering pumps, regularly check for the presence of lubricant, for example by checking the liquid level, visual leak control etc. If oil is leaking, examine the leakage point immediately and eliminate the cause.
- Check the correct operation of the relief valve downstream of the pump. In premises at risk from explosion, the relief valve should prevent the gear from becoming overloaded and becoming hot.
- Observe the enclosed operating instructions for the Ex motor.
- Check / replace the worn gear ring etc. of the clutch.
- When cleaning plastic components, ensure that no electrostatic charge is generated by the use of too dry a cloth.
- Prevent serious deposits of dust on the motor.
- Consider potential equalisation before you approach any pump equipment that could be at a different electrical potential (such as pipes or tools).
- Only with stroke control motor: Wait 3 minutes after switching off before opening the housing.
- Replace wear parts, such as bearings, when there is an identifiable incidence of unacceptable wear.
- Appropriate diagnostic equipment for bearing damage is recommended for the premature detection of bearing damage.
- Check whether the potential equalisation lines are all sitting correctly with clean contacts. Use the equipotential bonding drawings as an aid – see Appendix.
- Check whether the earth lines are all sitting correctly with clean contacts. Use the equipotential bonding drawings as an aid – see Appendix.
- Only use genuine spare parts as replacements.

ATEX pumps in areas at risk from explosion

- Static electricity can cause ignition sparks
- Always earth the pressure line and suction line first before working on the pump.

Before commencing all work



WARNING!

Danger from hazardous substances!

Possible consequence: Fatal or very serious injuries.

Please ensure when handling hazardous substances that you have read the latest safety data sheets provided by the manufacture of the hazardous substance. The actions required are described in the safety data sheet. Check the safety data sheet regularly and replace, if necessary, as the hazard potential of a substance can be re-evaluated at any time based on new findings.

The system operator is responsible for ensuring that these safety data sheets are available and that they are kept up to date, as well as for producing an associated hazard assessment for the workstations affected.

1. ➤ Disconnect the pump from the power supply.
2. ➤ Depressurise the pump.
3. ➤ Use a suitable flushing medium to flush the pump, referring to the material safety data sheet for the feed chemical.

11.2 Inspection, daily

Check the pump installation for:

- leaks
- abnormal noises or squeaks
- abnormal temperatures
- abnormal odours
- abnormal vibrations
- other anomalies



WARNING!

In the area at risk from explosion: Stop the pump safely and as quickly as possible and rectify these anomalies. ProMinent Service may be needed if required.

11.3 Standard liquid ends

Under heavy loading (e.g. continuous operation) shorter maintenance intervals are recommended than those given.

Third-party spare parts for the pumps can lead to problems when pumping.

- Only use original spare parts.
- Use the correct spare parts kits. If in doubt, refer to the exploded views and order information in the appendix or on our website www.prominent.com.

Interval	Maintenance work	Personnel
Quarterly*	<ul style="list-style-type: none"> ■ Check that the metering lines are tight at the liquid end and check for leak-tightness. ■ Check that the suction valve and discharge valve are firmly fixed in place and tightly sealed. ■ Check the leak-tightness of the entire liquid end - particularly around the leakage hole! With critical applications, check or replace the diaphragm at regular intervals - see  'Check the condition of the metering diaphragm' on page 49. ■ Check that the dosing head screws are tight. ■ Check that the diaphragm rupture sensor is firmly seated. ■ Check whether the diaphragm rupture sensor stops the pump or generates an alarm after it has been triggered. ■ Check that the flow is correct: Allow the pump to prime briefly. Observe the maximum permissible operating pressure! ■ Check the oil level. ■ Check that the electrical connections are intact. ■ Check the tight, clean electrical connection of the earthing wires. ■ Check the tight, clean electrical connection of the potential equalisation wires. 	Technical personnel
After approx. 4000 operating hours	Check the gear ring / double tooth (DZ) element of the coupling as per their operating instructions.	Technical personnel
After approx. 5000 operating hours	Change gear oil - refer to "Changing gear oil" in this chapter.	Instructed personnel
After 18,000 operating hours or 23,500 operating hours (API)	Adhere to the motor manufacturer's recommendations - see operating instructions for the motor.	

* With normal loading (approx. 30% of continuous operation).

Under heavy loading (e.g. continuous operation, aggressive feed chemicals etc.): shorter intervals.

Check the condition of the metering diaphragm

The diaphragm is a wearing part, the service life of which is dependent on the following parameters:

- System back pressure
- Operating temperature
- Feed chemical properties

The diaphragm service life is reduced when using abrasive feed chemicals. In these cases, more frequent checking of the diaphragm is recommended.

Tightening torques

Data	Value	Unit
Tightening torque for screws:	7.5±0.5	Nm

Liquid ends with integral relief valve



WARNING!

Warning of eye injuries

When opening the relief valve, a spring under high tension can jump out.

- Wear protective glasses.

Changing gear oil

Draining gear oil

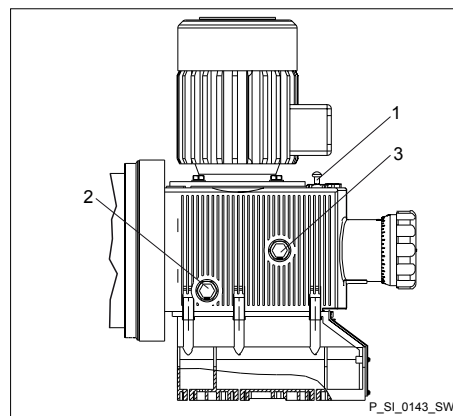

Fig. 21

1. ➤ Unscrew the vent screw (1).
2. ➤ Place an oil trough under the oil drainage plug (2).
3. ➤ Unscrew the oil drainage plug (2) from the power end housing.
4. ➤ Allow the gear oil to drain out of the power end.
5. ➤ Screw in the oil drainage plug (2) with a new seal.

Filling with gear oil

Requirement: Gear oil in line with the "Ordering information" chapter is available.

1. ➤ Slowly pour gear oil through the vent screw (1) opening until the oil inspection window (3) is half covered.
2. ➤ Allow the pump to run for 1... 2 minutes
3. ➤ Replace the vent screw (1).



WARNING!

Only in areas at risk from explosion:

Check after 1 day whether the oil drainage plug (2) is still tight.

12 Repair

12.1 Safety information, repair

ATEX pumps in areas at risk from explosion

- Carry out a general check to ensure that the system is functioning properly, particularly the power end and the bearings, by regular monitoring for leaks, noises, temperatures, smell etc.

Before commencing all work



WARNING!

Danger from hazardous substances!

Possible consequence: Fatal or very serious injuries.

Please ensure when handling hazardous substances that you have read the latest safety data sheets provided by the manufacture of the hazardous substance. The actions required are described in the safety data sheet. Check the safety data sheet regularly and replace, if necessary, as the hazard potential of a substance can be re-evaluated at any time based on new findings.

The system operator is responsible for ensuring that these safety data sheets are available and that they are kept up to date, as well as for producing an associated hazard assessment for the workstations affected.

1. ➤ Disconnect the pump from the power supply.
2. ➤ Depressurise the pump.
3. ➤ Use a suitable flushing medium to flush the pump, referring to the material safety data sheet for the feed chemical.

12.2 Cleaning valves

Third-party spare parts for the pumps can lead to problems when pumping.

- Only use original spare parts.
- Use the correct spare parts kits. If in doubt, refer to the exploded views and order information in the appendix or on our website www.prominent.com.

Only with "Physiologically safe" design:



WARNING!

Product can be dangerously contaminated

Only use the spare parts from the "Physiologically safe" spare parts kits.

Repairing ball valves

Feed chemical may escape from the liquid end, for example, if ball valves are not repaired correctly.

- Only use new components which fit your valve, both in terms of shape and chemical resistance!
- Note the flow direction of the pressure and suction connectors when fitting the valve.



CAUTION!

Warning of feed chemical spraying around

PTFE seals, which have already been used / compressed, can no longer reliably seal a hydraulic connection.

- New, unused PTFE seals must always be used.

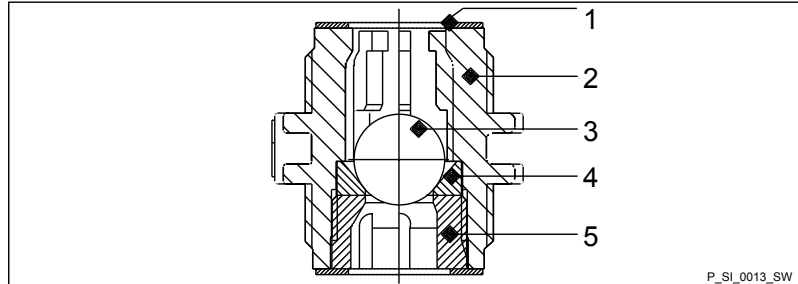

Fig. 22: Ball valve, simple, cross-section

- 1 Flat seal
- 2 Valve body
- 3 Valve ball
- 4 Valve seat
- 5 Valve cap

12.3 Replacing the diaphragm

Third-party spare parts for the pumps can lead to problems when pumping.

- Only use original spare parts.
- Use the correct spare parts kits. If in doubt, refer to the exploded views and order information in the appendix or on our website www.prominent.com.

Personnel: ■ Technical personnel

Requirements:

- Put in place protective measures, if necessary.
 - Note the material safety data sheet for the feed chemical.
 - Ensure that the system is at atmospheric pressure.
1. ➤ Drain the liquid end: turn the liquid end upside down and allow the feed chemical to drain; use a suitable medium to thoroughly flush the liquid end.
 2. ➤ With the pump running, move the stroke adjustment dial to the stop at 0% stroke length.
 - ⇒ The drive axle is now difficult to turn.
 3. ➤ Switch off the pump.
 4. ➤ Unscrew the hydraulic connectors from the discharge and suction side.
 5. ➤ Unscrew the diaphragm rupture sensor from the dosing head.
 6. ➤ Remove the 6 screws on the dosing head.
 7. ➤ Remove the dosing head.
 8. ➤ Check the condition of the diaphragm rupture sensor - see [☞ 'Checking the condition of the diaphragm rupture sensor' on page 54.](#)
 9. ➤ Loosen the diaphragm from the drive axle with a gentle backwards turn in an anti-clockwise direction.
 10. ➤ Completely unscrew the diaphragm from the drive axle.
 11. ➤ Tentatively screw the new diaphragm anticlockwise up to the stop on the drive axle.
 - ⇒ The diaphragm is now seated at the stop of the thread while the diaphragm flap is within the tolerance range.

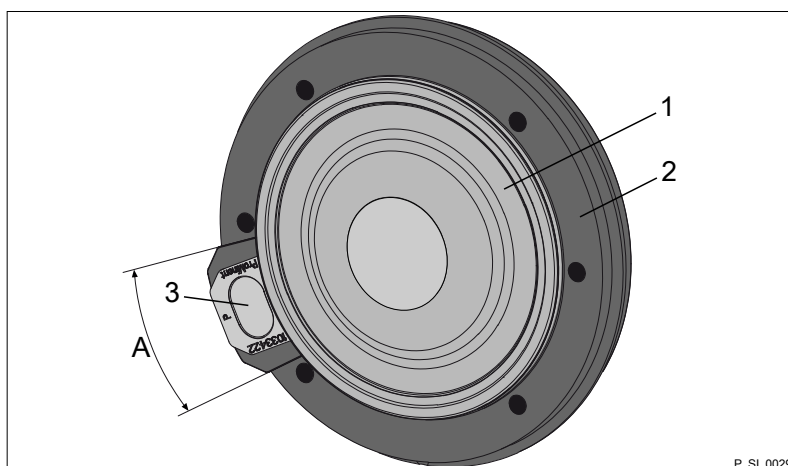

Fig. 23: Tolerance range of the flap on the backplate

- 1 Diaphragm
- 2 Backplate
- 3 Flap
- A Tolerance range

12. ▶ Should this not work, remove dirt or swarf from the thread and screw the diaphragm correctly onto the drive axle this time.
 - ⇒ If this is still unsuccessful, contact ProMinent-ProMaqua Service.
13. ▶ Place the dosing head with the screws onto the diaphragm - the suction connector should be pointing downwards when the pump is subsequently installed.
14. ▶ Tighten the screws gently to start with.
15. ▶ Screw the diaphragm rupture sensor into the dosing head.
16. ▶ Start the pump and adjust the stroke length to 100%.
17. ▶ Stop the pump and tighten the screws crosswise. Tightening torque - see .
18. ▶ Start the pump and check for leaks at maximum pressure.

If the tightening torque of the screws is not checked, the liquid end may leak.

- Check the tightening torque of the screws after 24 hours of operation.
- Re-check the tightening torques quarterly with PP, PC and TT dosing heads.

Checking the condition of the diaphragm rupture sensor

1. ▶ Replace the diaphragm rupture sensor if its inside has become damp or dirt has penetrated it.

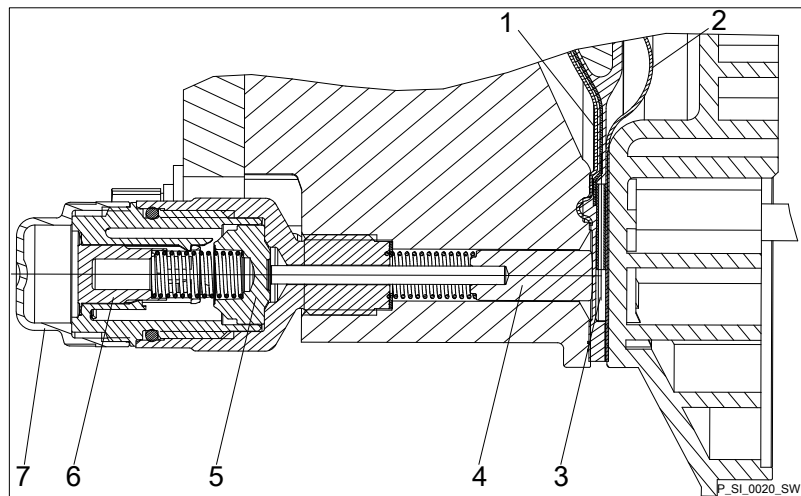

Fig. 24: Section through the Sigma diaphragm rupture warning system ("Visual rupture indicator" design)

- 1 Working layer ($\hat{=}$ operating diaphragm)
 - 2 Safety layer ($\hat{=}$ safety diaphragm)
 - 3 Flap
 - 4 Piston
 - 5 Diaphragm rupture sensor
 - 6 Cylinder, red
 - 7 Cover, transparent
2. ▶ If the piston of the diaphragm rupture sensor - see Fig. 24, item 4 - should have become dirty or damp, clean both it and the hole in which it runs.
 3. ▶ Check whether the piston can move freely in the hole.
 4. ▶ Reassemble the clean diaphragm rupture sensor with the clean piston.
 5. ▶ Test the diaphragm rupture sensor:

Optical diaphragm rupture sensor

1. ➤ Unscrew the transparent cover from the diaphragm rupture sensor.
2. ➤ Press the red cylinder into the diaphragm rupture sensor until the cylinder engages.
3. ➤ Press the piston on the other side of the diaphragm rupture sensor into the dosing head (approximately 4 mm) using a blunt, smooth object until it triggers.

Feed chemical can escape in the event of a diaphragm rupture if the expandable flap of the diaphragm is damaged.

Make sure that the piston is not scratched. It must remain completely smooth so that the piston does not damage the expandable flap of the diaphragm during operation.

4. ➤ Press the red cylinder into the diaphragm rupture sensor again and repeat the test.
5. ➤ If it does not trigger both times, replace the diaphragm rupture sensor.
6. ➤ After a successful test, screw the transparent cover onto the diaphragm rupture sensor and then continue at the top by assembling the diaphragm.

Electrical diaphragm rupture sensor

1. ➤ Press the piston of the diaphragm rupture sensor into the dosing head (approximately 4 mm) using a blunt, smooth object until the monitor triggers an alarm.

Feed chemical can escape in the event of a diaphragm rupture if the expandable flap of the diaphragm is damaged.

Make sure that the piston is not scratched. It must remain completely smooth so that the piston does not damage the expandable flap of the diaphragm during operation.

2. ➤ Repeat the test.
3. ➤ Replace the diaphragm rupture sensor if the monitor does not trigger an alarm both times.
4. ➤ After a successful test, continue at the top by assembling the diaphragm.

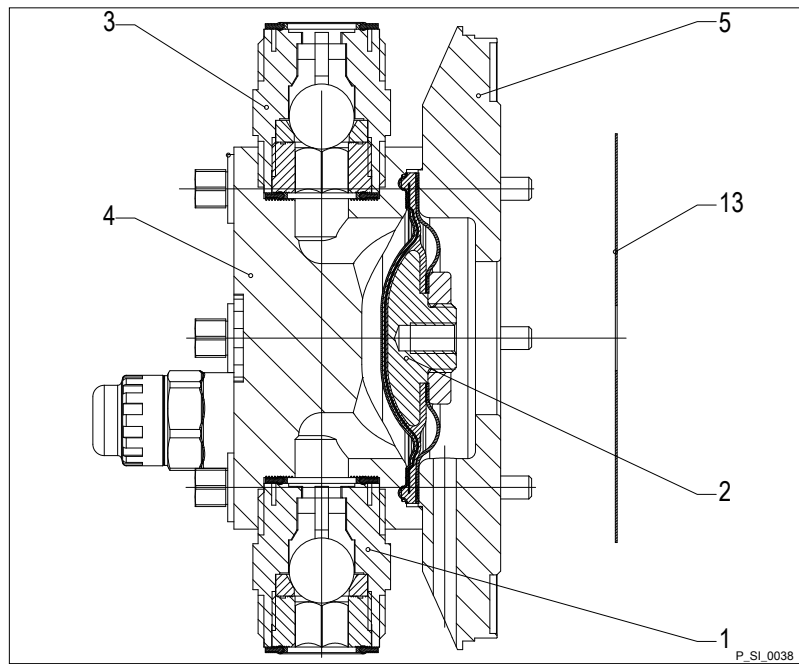

Fig. 25: Cross-section through the liquid end

- 1 Suction valve
- 2 Diaphragm
- 3 Discharge valve
- 4 Dosing head
- 5 Backplate
- 13 Safety diaphragm

13 Troubleshooting

Before commencing all work



WARNING!

Danger from hazardous substances!

Possible consequence: Fatal or very serious injuries.

Please ensure when handling hazardous substances that you have read the latest safety data sheets provided by the manufacture of the hazardous substance. The actions required are described in the safety data sheet. Check the safety data sheet regularly and replace, if necessary, as the hazard potential of a substance can be re-evaluated at any time based on new findings.

The system operator is responsible for ensuring that these safety data sheets are available and that they are kept up to date, as well as for producing an associated hazard assessment for the workstations affected.

1. ➤ Disconnect the pump from the power supply.
2. ➤ Depressurise the pump.
3. ➤ Use a suitable flushing medium to flush the pump, referring to the material safety data sheet for the feed chemical.

Safety information

ATEX pumps in areas at risk from explosion

- Generally ensure that the parts are working properly (no leaks, unusual noises, high temperatures, unusual smell ...) especially the power end/drive and the bearings.
- Do not allow the pump to run hot.
With lubricated metering pumps, regularly check for the presence of lubricant, for example, by checking the liquid level, visual leak control, etc. If oil is leaking, examine the leakage point immediately and eliminate the cause.
- Only use a moist cloth when cleaning plastic parts to avoid electrostatic charge.
- Replace wear parts, such as bearings, when there is an identifiable incidence of unacceptable wear. The nominal service life cannot be calculated with lubricated bearings.



WARNING!

Only motors with a frequency converter: Danger of electric shocks

- The danger of an electric shock remains for 3 minutes after the mains voltage has been switched off on conducting parts of the motor with integrated frequency converter and on the lines themselves.
- After switching off, allow the unit to stand for 3 minutes before opening the terminal box.



CAUTION!

Only motors with a frequency converter: The motor can be damaged

- The input current limiter could be damaged if a motor with integrated frequency converter is restarted within 3 minutes of the mains voltage being switched off.
- After switching off, allow the unit to stand for at least 3 minutes before restarting.

1. ➤ Disconnect the pump from the mains power supply.
2. ➤ Depressurise and bleed the hydraulic environment of the pump.

3. ➤ Use a suitable medium to flush the pump, referring to the relevant material safety data sheet. Thoroughly rinse the dosing head.
4. ➤ Thoroughly clean the pump to ensure that it does not present a risk.

Tasks

Fault description	Cause	Remedy	Personnel
Pump does not prime despite full stroke motion and degassing.	The valves are dirty or worn.	Repair the valves - see "Repair" chapter.	Technical personnel
	The feed chemical has particles larger than 0.3 mm.	Install an appropriate filter in the suction line.	Technical personnel
Pump does not reach high pressure rates.	The valves are dirty or worn.	Repair the valves - see "Repair" chapter.	Technical personnel
	The motor is wired incorrectly.	1. Check the mains voltage and mains frequency. 2. Wire the motor correctly.	Electrician
	The mains voltage has decreased.	Eliminate the cause.	Electrician
Fluid escapes from the back-plate.	The dosing head screws are no longer tight enough.	Tighten the screws crosswise to the specified tightening torque.	Technical personnel
	The diaphragm leaks.**	Replace the diaphragm - refer to the "Repair" chapter.	Technical personnel
Large leaks occur at the relief valve.	The ball or ball seat are dirty or worn.	Clean or replace the ball and ball seat.*	Technical personnel
The diaphragm rupture sensor has triggered.	The operating diaphragm has ruptured.**	Replace the diaphragm - refer to the "Repair" chapter.	Technical personnel
The drive motor is very hot.	The pressure line is seriously constricted.	Remove any constriction of the pressure line.	Technical personnel
All other faults.	Other causes.	Call ProMinent Service.	

* If necessary use the cross-section drawing of the integral relief valve in the "Functional Description" chapter.



WARNING!

Warning of eye injuries

When opening the relief valve, a spring under high tension can jump out.

- Wear protective glasses.

**

Leaking feed chemical

- When dosing combustible feed chemicals or in areas at risk from explosion, under no circumstances must the second diaphragm also rupture.
- If the diaphragm rupture sensor triggers, stop the pump safely and as quickly as possible. Only restart the pump once a new multi-layer safety diaphragm is fitted.



CAUTION!

Warning of inaccurate dosing

Once the operating membrane has ruptured, precise dosing of the pump can no longer be guaranteed.

- Do not continue to use the pump for critical process dosing.
- For uncritical processes, the pump can continue to be operated for some time after the break in emergency service mode at full operating pressure and free from leaks up until replacement of the diaphragm.

Only with "Physiologically safe" design:

Following a diaphragm rupture, the feed chemical is in contact with physiologically harmful materials until the diaphragm is replaced. The feed chemical can become contaminated.

14 Decommissioning

Before commencing all work



WARNING!

Danger from hazardous substances!

Possible consequence: Fatal or very serious injuries.

Please ensure when handling hazardous substances that you have read the latest safety data sheets provided by the manufacture of the hazardous substance. The actions required are described in the safety data sheet. Check the safety data sheet regularly and replace, if necessary, as the hazard potential of a substance can be re-evaluated at any time based on new findings.

The system operator is responsible for ensuring that these safety data sheets are available and that they are kept up to date, as well as for producing an associated hazard assessment for the workstations affected.

1. ➤ Disconnect the pump from the power supply.
2. ➤ Depressurise the pump.
3. ➤ Use a suitable flushing medium to flush the pump, referring to the material safety data sheet for the feed chemical.

Decommissioning



WARNING!

Danger from hazardous substances!

Possible consequence: Fatal or very serious injuries.

Please ensure when handling hazardous substances that you have read the latest safety data sheets provided by the manufacture of the hazardous substance. The actions required are described in the safety data sheet. Check the safety data sheet regularly and replace, if necessary, as the hazard potential of a substance can be re-evaluated at any time based on new findings.

The system operator is responsible for ensuring that these safety data sheets are available and that they are kept up to date, as well as for producing an associated hazard assessment for the workstations affected.

There is normally chemical residue in the liquid end and on the housing after operation. This chemical residue could be hazardous to people.

- It is mandatory that the safety information in the "Storage, transport and unpacking" chapter is read before shipping or transporting the unit.
- Thoroughly clean the liquid end and the housing of chemicals and dirt. Pay attention to the material safety data sheet for the feed chemical.



WARNING!

Warning of eye injuries

When opening the relief valve, a spring under high tension can jump out.

- Wear protective glasses.

The unit may be damaged by incorrect and improper storage and transport.

- Take into account the information in the "Storage, transport and unpacking" chapter if the system is decommissioned for a temporary period.

(Temporary) decommissioning

1. ➤ Disconnect the pump from the mains/power supply.
2. ➤ Depressurise and vent the hydraulic system around the pump.
3. ➤ Drain the liquid end by turning the pump upside down and allowing the feed chemical to run out.
4. ➤ Flush the liquid end with a suitable medium, observing the material safety data sheet. Thoroughly rinse the dosing head.
5. ➤ For possible additional work refer to the Chapter "Storage, transport and unpacking".

Final decommissioning

- Also drain the gear oil - refer to the "Maintenance" chapter.

Disposal

Environmental hazard due to incorrect disposal

- Note the local guidelines currently applicable in your country, particularly with regard to electronic waste.

Environmental hazard due to gear oil

- The pump contains gear oil, which can cause damage to the environment.
- Drain the gear oil from the pump.
- Note the local guidelines currently applicable in your country!

15 Technical data

Only with "M - modified" design:



WARNING!

Risk of personal injuries

Please observe the "Supplement for modified version" at the end of the chapter!

It replaces and supplements the technical data!

15.1 Performance data

S2Ba at 50 Hz operation

Type	Minimum pump capacity at maximum back pressure			Maximum stroke rate	Suction lift	Permissible priming pressure, suction side	Connector size
	bar	l/h	ml/stroke				
16050 PVT	10	50	11.4	73	7	3	1A - 15
16050 SST	16	47	11.4	73	7	3	1A - 15
16090 PVT	10	88	11.4	132	7	3	1A - 15
16090 SST	16	82	11.4	132	7	3	1A - 15
16130 PVT	10	135	10.9	198	7	3	1A - 15
16130 SST	16	124	10.9	198	7	3	1A - 15
07120 PVT	7	126	27.4	73	5	1	20*
07120 SST	7	126	27.4	73	5	1	20*
07220 PVT	7	220	27.7	132	5	1	20*
07220 SST	7	220	27.7	132	5	1	20*
04350 PVT	4	350	29.4	198	5	1	20*
04350 SST	4	350	29.4	198	5	1	20*

Performance data for TTT, see type PVT

Performance data for PVF/SSF, see PVT/SST

All figures apply to water at 20 °C.

The suction lift applies to a filled suction line and filled liquid end - when installed correctly.

* With Sigma types 07120, 07220 and 04350, the valves in the dosing head are configured as DN 25 (G1 1/2A male). As DN 20 is generally sufficient for the pipework for these types (see technical data, suction/discharge side connector), the connector parts that can be ordered with the identity code (e.g. inserts) are already reduced to DN 20, i.e. DN 20 pipework and accessories can be installed.

S2Ba at 60 Hz operation

Type	Minimum pump capacity at maximum back pressure				Maximum stroke rate	Suction lift	Permissible priming pressure, suction side	Connector size
	bar	psi	l/h	gph				
16050 PVT	10	145	60	15.9	87	7	3	1" - 15
16050 SST	16	232	56	14.8	87	7	3	1" - 15
16090 PVT	10	145	106	27.8	158	7	3	1" - 15
16090 SST	16	232	98	26.0	158	7	3	1" - 15
16130 PVT	10	145	163	41.0	238	7	3	1" - 15
16130 SST	16	232	148	39.2	238	7	3	1" - 15
07120 PVT	7	102	150	39.7	87	5	1	20*
07120 SST	7	102	150	39.7	87	5	1	20*
07220 PVT	7	102	264	69.7	158	5	1	20*
07220 SST	7	102	264	69.7	158	5	1	20*
04350 PVT	4	58	420	108.0	238	5	1	20*
04350 SST	4	58	420	108.0	238	5	1	20*

Performance data for TTT, see type PVT

Performance data for PVF/SSF, see PVT/SST

All figures apply to water at 20 °C.

The suction lift applies to a filled suction line and filled liquid end - when installed correctly.

* With Sigma types 07120, 07220 and 04350, the valves in the dosing head are configured as DN 25 (G1 1/2A male). As DN 20 is generally sufficient for the pipework for these types (see technical data, suction/discharge side connector), the connector parts that can be ordered with the identity code (e.g. inserts) are already reduced to DN 20, i.e. DN 20 pipework and accessories can be installed.

Precision

Data	Value	Unit
Reproducibility	±2	% *

* - when installed correctly, under constant conditions, at least 30% stroke length and water at 20 °C

15.2 Viscosity

Tab. 6: The liquid ends are suitable for the following viscosity ranges:

Design	Stroke rate, max.	Viscosity
	Strokes/min	mPas
Standard	200	0 ... 200
With valve springs	130	200 ... 500
With valve springs and suction-side feed	90	500 ... 1000*

* Only when the installation is correctly adjusted.

15.3 Shipping weight

Types	Material version	Shipping weight
		kg
16050 ... 16130	PVT, TTT	15
	SST	20
07120 ... 04350	PVT, TTT	16
	SST	24

15.4 Wetted materials

Material version	Liquid end	Suction/pressure connector	Seals* / ball seat	Balls	Springs	Integral relief valve
PVT	PVDF	PVDF	PTFE / PTFE	Ceramic / glass **	Hastelloy C4	PVDF/FPM or EPDM
TTT	PTFE + 25% carbon	PVDF	PTFE / PTFE	Ceramic	Hastelloy C4	PVDF/FPM or EPDM
SST	Stainless steel 1.4404	Stainless steel 1.4581	PTFE / PTFE	Stainless steel 1.4404	Hastelloy C4	Stainless steel/FPM or EPDM

* Diaphragm is PTFE-coated

** Types 07120, 07220, 04350

15.5 Ambient conditions

15.5.1 Ambient temperatures

Pump, compl.

Data	Value	Unit
Storage and transport temperature	-10 ... +50	°C
Ambient temperature in operation (drive + motor):	-10 ... +45	°C

15.5.2 Media temperatures

Liquid end PVT, PVF

Data	Value	Unit
Max. temperature, long-term at max. operating pressure	65	°C
Max. temperature, for 15 minutes at max. 2 bar	100	°C
Minimum temperature.	-10	°C

TTT liquid end

Data	Value	Unit
Max. temperature, long-term at max. operating pressure	50	°C
Minimum temperature.	-10	°C

Liquid end SST, SSF

Data	Value	Unit
Max. temperature, long-term at max. operating pressure	90	°C
Max temperature, for 15 minutes at max. 2 bar	120	°C*
Minimum temperature.	-10	°C

* not in areas at risk from explosion

15.5.3 Air humidity

Air humidity

Air humidity, max. 92 % relative humidity, non-condensing.

15.6 Installation height

Data	Value	Unit
Maximum installation height*:	1000	m above standard zero

* with standard pumps: Fit at higher installation heights at your own risk.

with ATEX pumps: We urgently advise that you contact a specialist for ATEX motors at higher installation heights!

15.7 Motor data

Electrical data

Identity code specification	Phases, protection	Rated voltage	Mains frequency	Rated output	Remarks
S	3-phase, IP 55	220-240 V / 380-420 V	50 Hz	0.25kW	
		265-280 V / 440-480 V	60 Hz	0.25 kW	
T	3-phase, IP 55	220-240 V / 380-420 V	50 Hz	0.25 kW	With PTC, speed control range 1:5
		265-280 V / 440-480 V	60 Hz	0.25 kW	
R	3-phase, IP 55	230 V/400 V	50/60 Hz	0.37 kW	with PTC, speed control range 1:20, with external fan 1-phase 230 V; 50/60 Hz
V0	1-phase AC, IP 55	230 V ±5 %	50/60 Hz	0.37 kW	Variable speed motor with integrated frequency converter, control range 1:20
M	1-phase AC, IP 55	230 V ±5 %	50/60 Hz	0.18 kW	
N	1-phase AC, IP 55	115 V ±5 %	60 Hz	0.18 kW	

Identity code specification	Phases, protection	Rated voltage	Mains frequency	Rated output	Remarks
L1	3-phase, II 2G Ex h IIC Gb T3 X	220-240 V / 380-420 V	50 Hz	0.18 kW	
L2	3-phase, II 2G Ex h IIC Gb T4 X	220-240 V / 380-420 V	50 Hz	0.18 kW	With PTC, speed control range 1:5
P1	3-phase, II 2G Ex h IIC Gb T3 X	250-280 V / 440-480 V	60 Hz	0.18 kW	
P2	3-phase, II 2G Ex h IIC Gb T4 X	250-280 V / 440-480 V	60 Hz	0.21 kW	With PTC, speed control range 1:5



Motor data sheets, special motors, special motor flanges, external fan, temperature monitoring

- For further information on the motor with identity code specification "S", refer to our website www.prominent.com. Motor data sheets can be requested for all other motors.
- With motors other than those with identity code specifications "S", "M" or "N": Pay special attention to the operating instructions for the motors.
- Special motors or special motor flanges are available on request.

15.8 Stroke actuator

Voltage	Mains frequency	Output
85 ... 265 V AC	50/60 Hz	11.7 W

15.9 Stroke control drive

Voltage	Mains frequency	Output
85 ... 265 V AC	50/60 Hz	6.5 W

15.10 Diaphragm rupture sensor

Install the sensor in accordance with the chapter "Installation, electrical".

a) Contact (standard with identity code specification "Displacement mechanism": A)

Tab. 7: Contact loading, max.

with voltage	Maximum current
30 V DC	1 A

The diaphragm rupture sensor is an N/C.

- For safety reasons we recommend connection to protective low voltage, e.g. in accordance with EN 60335-1 (SELV).
- The cable can be connected as required.

a) Namur sensor (for identity code specification "Displacement mechanism": A)

Install the sensor in accordance with the chapter "Installation, electrical". Refer to its documentation.

Sensor name: NJ1.5-8GM-N.

5–25 V DC, in accordance with Namur or DIN 60947-5-6, potential-free design.

Data	Value	Unit
Nominal voltage *	8	V DC
Power consumption - active surface uncovered	> 3	mA
Power consumption - active surface covered	< 1	mA
Rated switching distance	1.5	mm

* Ri ~ 1 kΩ

Cable colour	Polarity
blue	-
brown	+

15.11 Stroke sensor "Sigma"

Install the sensor in accordance with the chapter "Installation, electrical".

a) Pacing relay (stroke sensor with ...)
(Identity code specification "Stroke sensor": 2)

For more information, see "Pacing relay" in the "Relay" chapter.

b) Namur sensor (identity code specification "Stroke sensor": 3)

Install the sensor in accordance with the chapter "Installation, electrical". Refer to its documentation.

Sensor name: NJ1.5-8GM-N.

5–25 V DC, in accordance with Namur or DIN 60947-5-6, potential-free design.

Data	Value	Unit
Nominal voltage *	8	V DC
Power consumption - active surface uncovered	> 3	mA
Power consumption - active surface covered	< 1	mA
Rated switching distance	1.5	mm

* Ri ~ 1 kΩ

Cable colour	Polarity
blue	-
brown	+

15.12 Relays

The electrical data for the relay is contained in the chapter "Installation, electrical".

15.13 Gear oil

Manufacturer	Name	Viscosity class (ISO 3442)	Order no.	Oil volume, supplied	Oil volume, needed approx.
Mobil	Mobil Gear 634 *	VG 460	1004542	1.0 l	0.55 l

* or comparative gear oil

15.14 Sound pressure level

Sound pressure level

Sound pressure level L_{pA} < 70 dB according to EN ISO 20361

at maximum stroke length, maximum stroke rate, maximum back pressure (water)

15.15 Supplementary information for modified versions

(With identity code specification "Version": "M" - "modified")

Technical data

Technical data of pumps in the modified version can deviate from those of the standard pumps. They can be queried by stating the details of the serial number.

During operation with an automatic stroke length adjustment control together with a variable speed motor, the stroke rate must not fall below 30 strokes / min. Otherwise technical problems occur, because the mechanical resistance of the stroke adjustment spindle becomes too high.

motor

The motor data sheets for the modified version are valid. They may deviate from the standard motor data sheets.

Spare parts

With a modified version, it is absolutely necessary to specify the details of the serial number requesting and ordering the spare and replacement parts.

16 Diagrams for setting the metering capacity

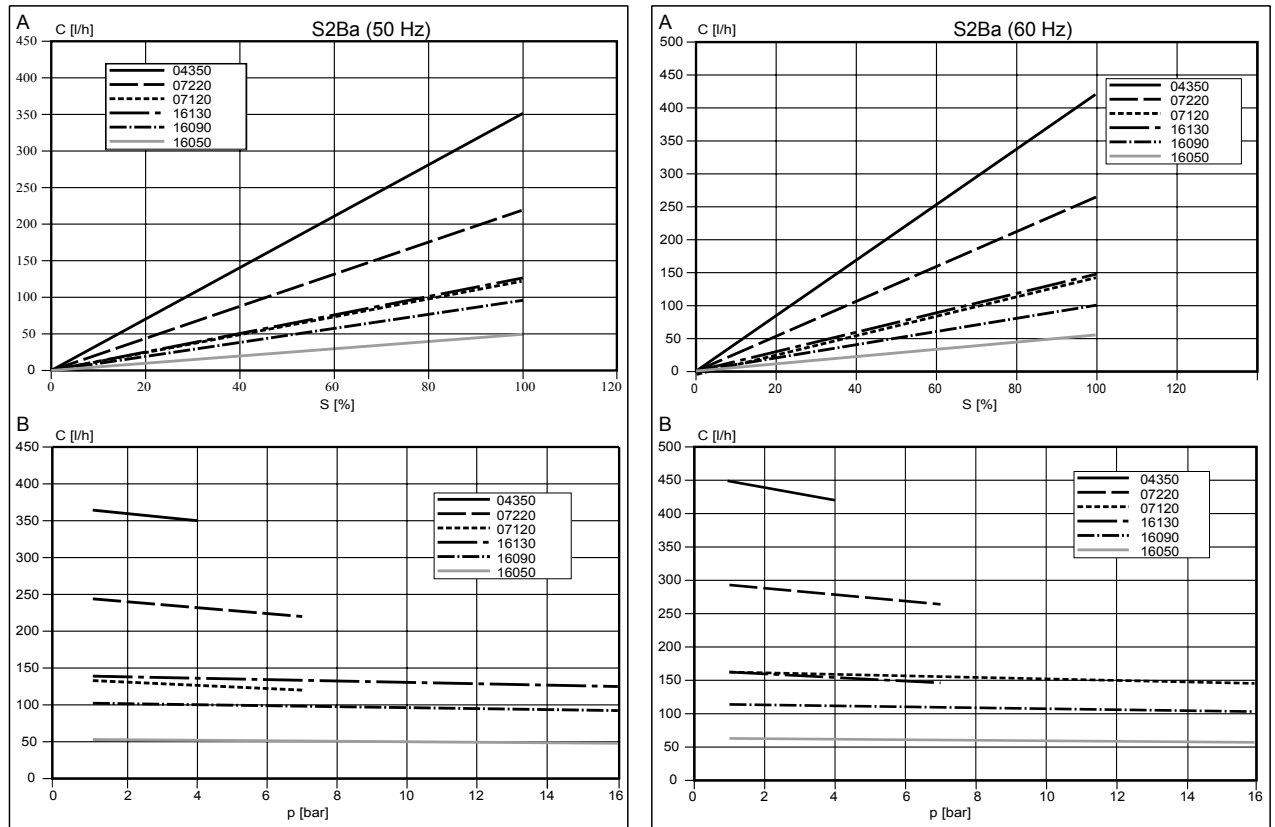

Fig. 26: A) Capacity C at minimum back pressure dependent on the stroke length s . B) Capacity C dependent on the back pressure p .

17 Dimensional drawings

i - Compare the dimensions on the dimension sheet and pump.
 - All dimensions are in mm.

Dimension sheet for S2Ba

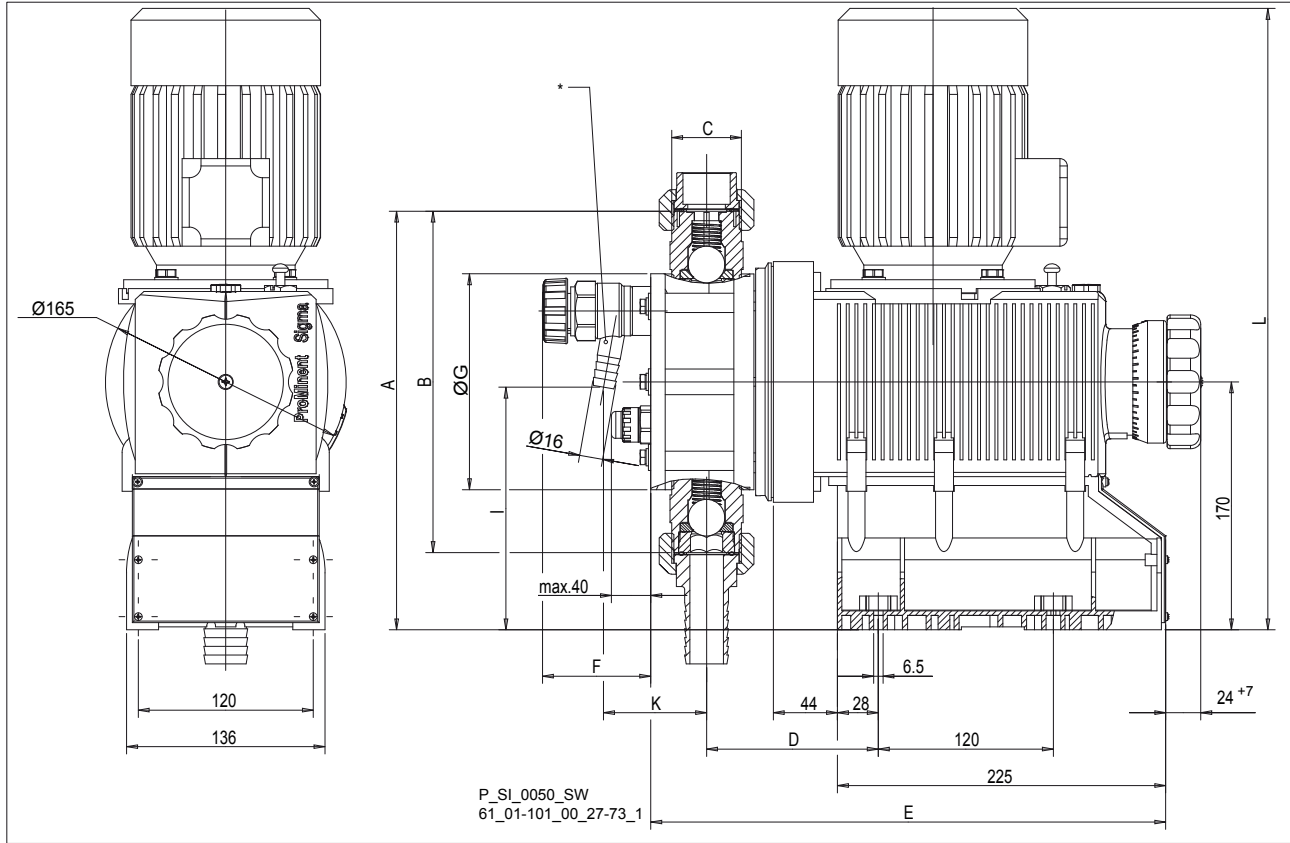

Fig. 27: Dimensions in mm - diagram is not binding.

Tab. 8: Dimensions in mm

Type	Connector	A	B	C	D	E	F	ØG	I	K
Sigma 04350, 07120, 07220 PVT / TTT	DN25	287	234	G 1/2 A	118	353	75	156	166	71
Sigma 04350, 07120, 07220 SST	DN25	287	233	G 1/2 A	118	345	88	159	140	60
Sigma 12050, 12090, 12130, 16050, 16090, 16130 PVT / TTT	DN25	251	162	G 1 A	111	341	72	122	148	63
Sigma 12050, 12090, 12130, 16050, 16090, 16130 SST	DN25	251	162	G 1 A	110	330	88	122	122	53

	Standard motor	Motor, control-lable	EExe motor	EExde motor	Motor with frequency con-verter	1-phase motor
L	426	523	472	448	644	443

Dimension sheet S2Ba, servomotor and motor flange

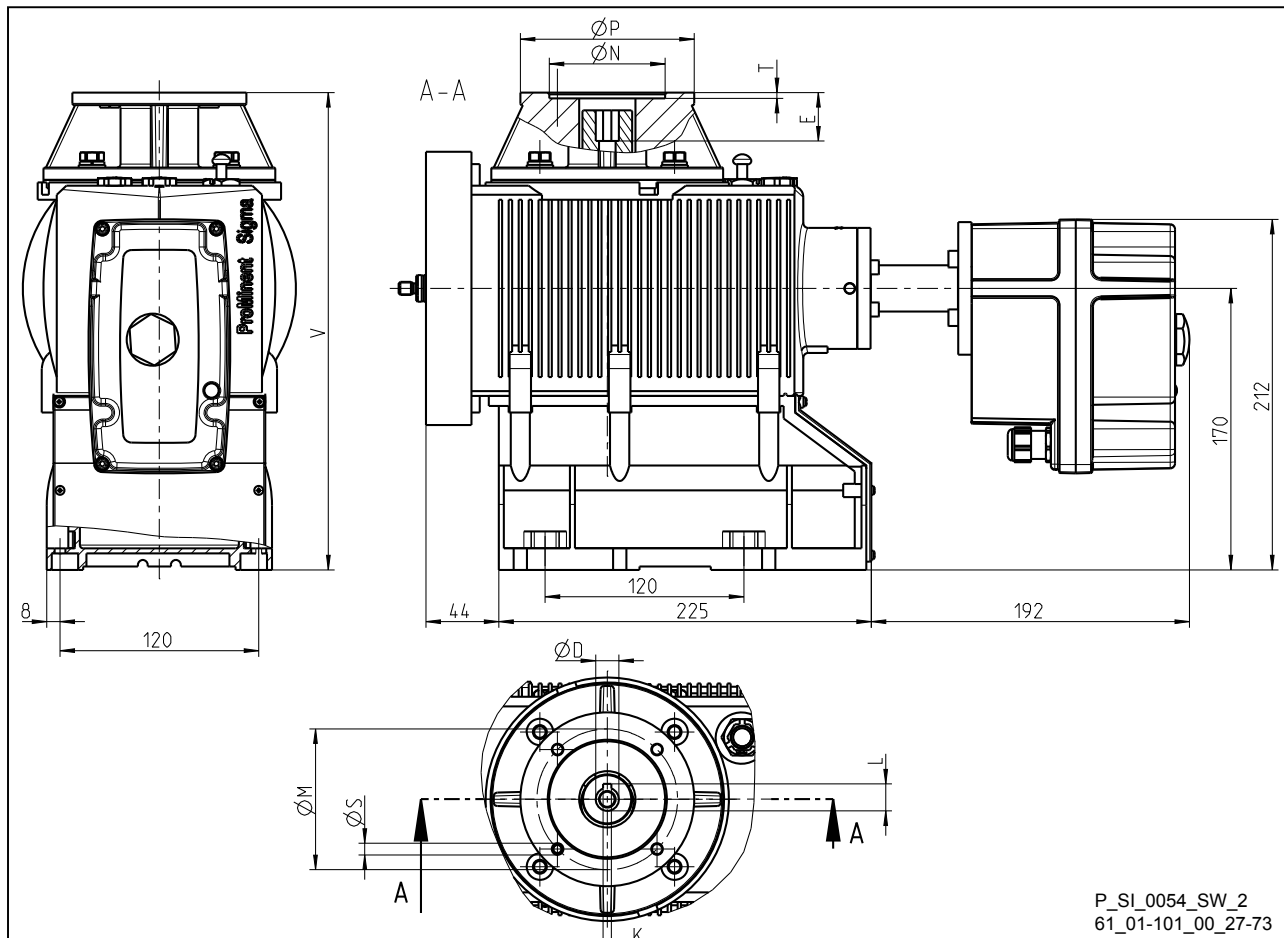

Fig. 28: Dimensions in mm - diagram is not binding.

Br. Sz.	Motorflansch motor flange	ØP	ØM	ØN	ØS	ØD	E	T	K	L	V
71	B 14/105	105	85	70	7	14	29	3.5	5	16.3	288
	56 C/138	5.43"	5.88"	4.5"	0.43"	0.62"	1.14"	0.16"	0.2"	0.72"	12.2"
71	B 14/160	160	130	110	9	14	29	6	5	16.3	290
80	B 14/200	200	165	130	11	19	52.5	6	6	21.8	323
63	B 5/140 *	140	115	95	9.5	11	26	3.5	4	12.8	230

18 Potential equalisation drawings for Sigma Basic Type

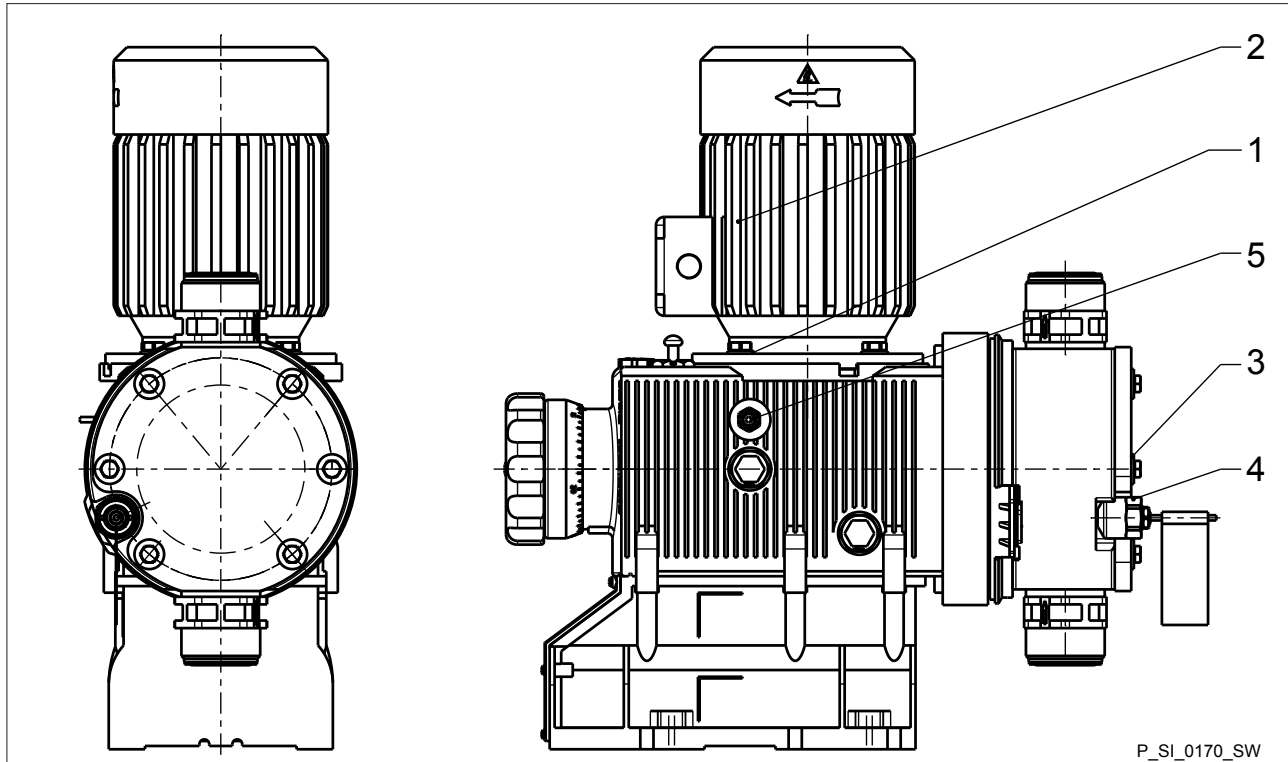

Fig. 29: Potential equalisation drawing for Sigma S2Ba

- 1 Potential equalisation of motor
- 2 Potential equalisation of motor flange
- 3 Potential equalisation of liquid end
- 4 Potential equalisation of diaphragm rupture indicator
- 5 Potential equalisation of stroke sensor

Positions 1, 2 and 5 must be connected to a protective earth cable.

Positions 3 and 4 must be connected to a protective earth cable.

19 Motor data sheet standard motor

Motor Datenblatt / Motor data sheet / Fiche technique pour moteur				
Bestell Nr. order no. / no. de commande	1011036	Hersteller producer / producteur	ATB Mat.Nr.. 376108	
Motor- Typ motor type type du moteur	AF63/4C-7	Leistungsfaktor power factor facteur de puissance	0,64 0,66	
Maschinenart type of machine désignation	3 Ph. Motor	Wirkungsgrad efficiency rendement	66% 69%	
Schutzart degree of protection degré de protection	IP55	Bemessungsfrequenz rated frequency fréquence nominale	50 / 60 Hz	
Bauform mounting construction	IMB5	Bemessungsdrehzahl rated speed vitesse nominale	1380 1680	U/min rpm t/mn
Bemessungsleistung rated output puissance nominale	0,250kW	Wärmeklasse temperature class class d'isolement	F	
Bemessungsspannung rated voltage tension nominale	▲ / Δ 380-420/220-240V 380-480/220-280V	Anzugsstrom starting current courant de démarrage	3,5/4,0	fach fold fois
Bemessungsstrom rated current courant nominale	0,89/1,54A 0,80/1,47A	Anzugsmoment starting torque couple de démarrage	2,3/2,4	fach fold fois
Geprüft nach tested in acc. with contrôlé selon	EN60034	Kippmoment pull-out torque couple de décrochage	2,4/2,7	fach fold fois
ATEX Nr.		Umgebungstemperatur ambient temperature température ambiante	40°C	
Ex-Schutzklasse ex-protective system		Schaltung connection branchement	▲ / Δ	
		Drehzahlregelbereich speed ajustment range		
Anmerkung comments observation	* auf Anfrage beim Hersteller * upon request at manufacturer * sur demande auprès du producteur			
ProMinent				
Pumpentyp	S2BaHM _____ S ____ S2CaHM _____ U _____ SiBa _____ S ____			
Die Daten entsprechen den Angaben der Motorenhersteller. Kenndaten funktionsgleicher Motoren anderer Hersteller ändern sich nur unwesentlich. Angaben ohne Gewähr. The data correspond to the details given by the motor manufacturers. Ratings of motors with the same functions made by other producers show insignificant changes only. This information is supplied without liability. Les données techniques correspondent au descriptif du fabricant des moteurs. Les données techniques des moteurs similaires chez d' autres fabricants varient très peu. Données sont d' ordre général.				

ProMinent®

20 Exploded drawings for Sigma/ 2

Liquid end Sigma/ 2 130-DN 15 and 350-DN 25 PVT

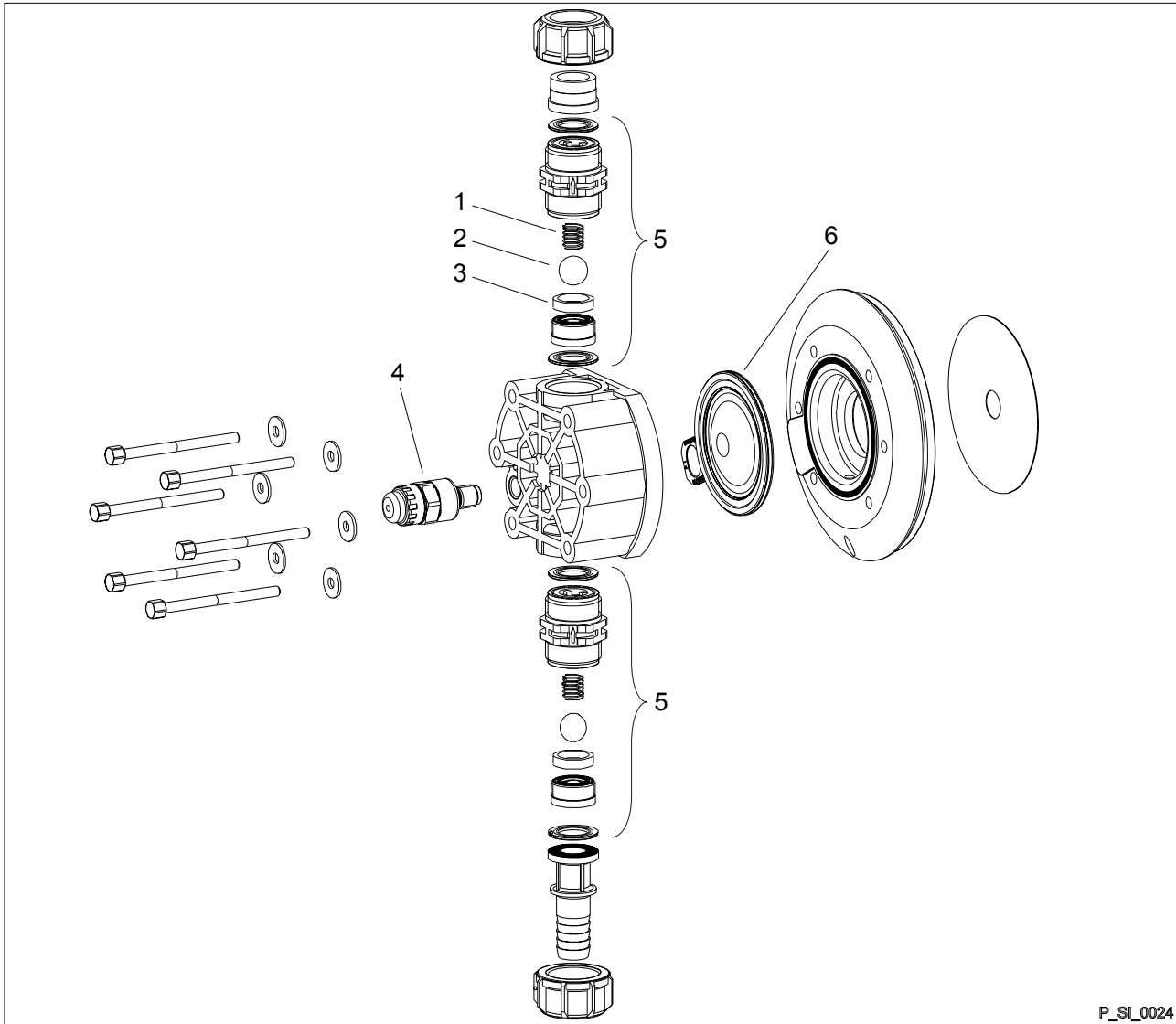

P_SI_0024

Fig. 30: Liquid end Sigma/ 2 130-DN 15 and 350-DN 25 PVT

Pos.	Description	Type 16050, 16090, 16130	Type 04350, 07120, 07220
1	Spring	**	**
2	Ball	*	*
3	Ball seat	-	-
4	Diaphragm rupture sensor, optical	1033323	1033323
5	Valve	792517*	740615*
6	Multi-layer diaphragm	1029771*	1033422*

* The items listed are included in the spare parts kit. ** Special accessories (not included in the spare parts kit). Technical changes reserved.

Sigma/ 2 PVA relief valve-A

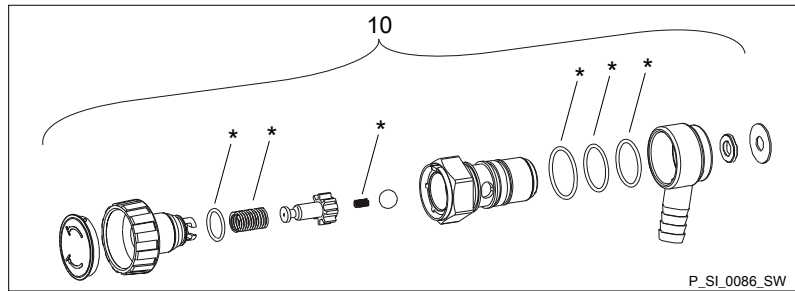
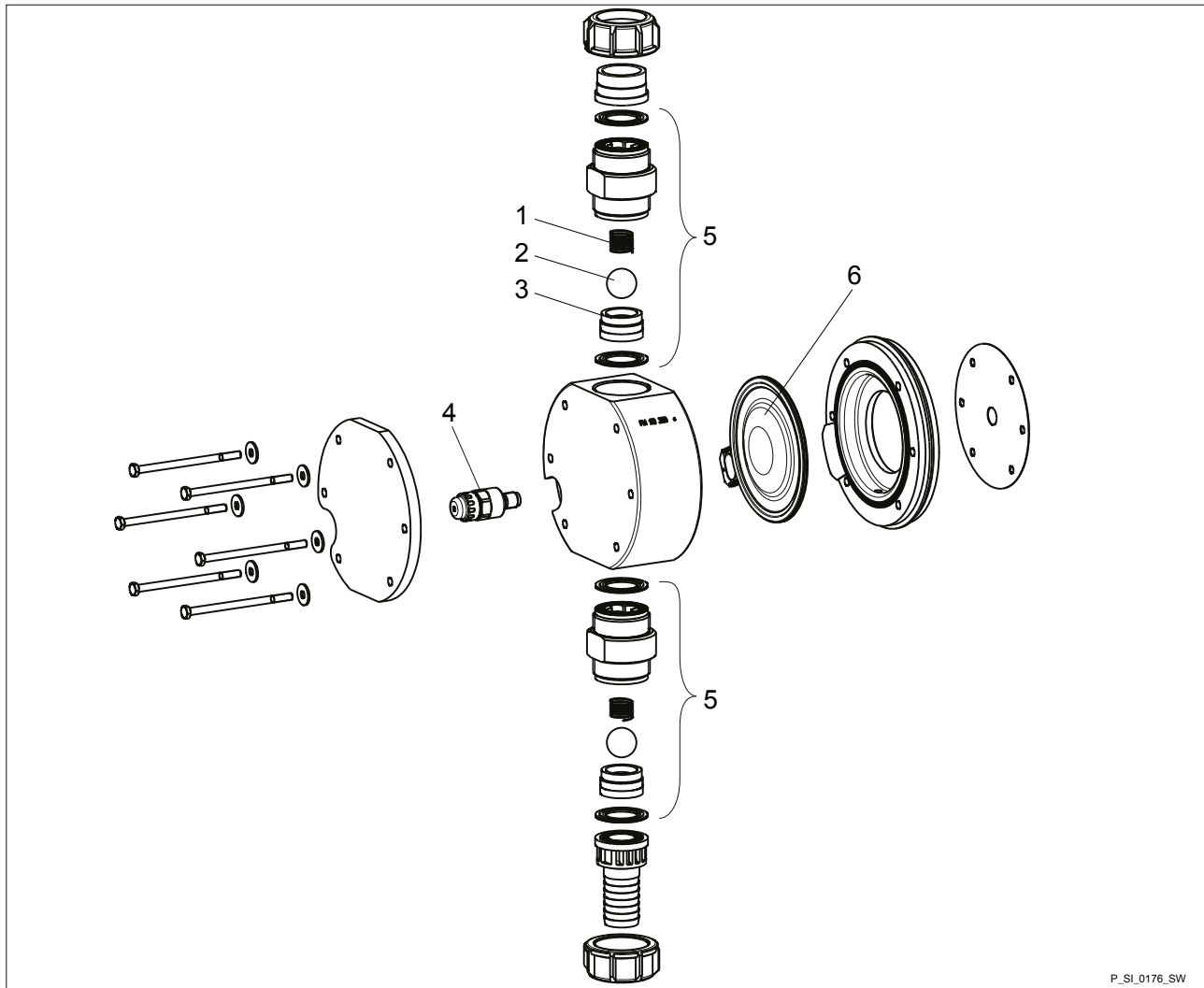

Fig. 31: Sigma/ 2 PVA relief valve-A

Pos.	Description	Type 16050, 16090, 16130	Type 07120, 07220	Type 04350,
10	Relief valve, complete 10 bar PVA	1018947		
10	Relief valve, complete 7 bar PVA		740811	
10	Relief valve, complete 4 bar PVA			740812

* The items listed are included in the spare parts kit. Springs made from Hastelloy C, O-rings from FPM-A and EPDM. Technical changes reserved.

Liquid end for Sigma/ 2 130 and 350 TTT



P_SI_0176_SW

Fig. 32: Liquid end for Sigma/ 2 130 and 350 TTT

Pos.	Description	Type 16050, 16090, 16130	Type 04350, 07120, 07220
1	Spring	*	*
2	Ball	*	*
3	Ball seat	-	-
4	Diaphragm rupture sensor, optical	1033323	1033323
5	Valve	809403	803706
6	Multi-layer diaphragm	1029771*	1033422*

* The items listed are included in the spare parts kit. Technical changes reserved.

Liquid end for Sigma/ 2 130 and 350 SST

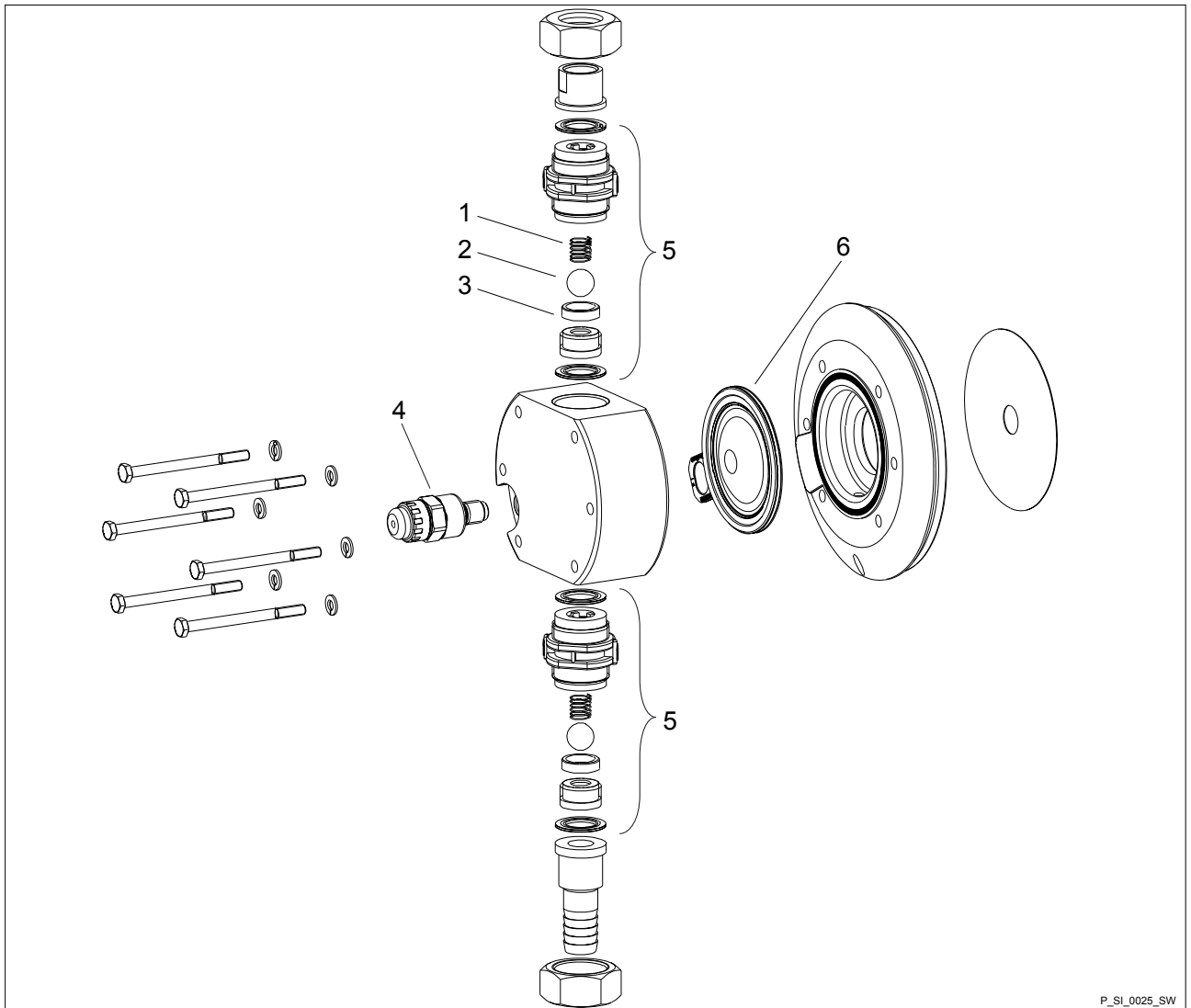

Fig. 33: Liquid end for Sigma/ 2 130 and 350 SST

Pos.	Description	Type 16050, 16090, 16130	Type 04350, 07120, 07220
1	Spring	*	*
2	Ball	*	*
3	Ball seat	-	-
4	Diaphragm rupture sensor, optical	1033323	1033323
5	Valve	809404	803708
6	Multi-layer diaphragm	1029771*	1033422*

* The items listed are included in the spare parts kit. Technical changes reserved.

Sigma/ 2 SSA relief valve-A

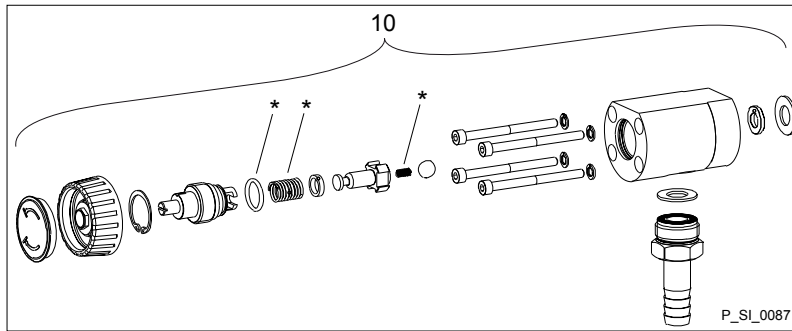

Fig. 34: Sigma/ 2 SSA relief valve-A

Pos.	Description	Type 16050, 16090, 16130	Type 07120, 07220	Type 04350, 04350
10	Relief valve, complete 16 bar SSA	1019246		
10	Relief valve, complete 7 bar SSA		740815	
10	Relief valve, complete 4 bar SSA			740814

* The items listed are included in the spare parts kit. Springs made from Hastelloy C, O-rings from FPM-A and EPDM. Technical changes reserved.

21 Wear parts of Sigma/ 2

Scope of delivery: - see exploded drawings.

21.1 Standard

Tab. 9: Spare parts kits types 16050, 16090, 16130

Liquid ends	Wetted materials	Remark	Order no.
FM 130 - DN15	PVT	-	1046472
FM 130 - DN15	TTT	-	1077573
FM 130 - DN15	SST	-	1046473
FM 130 - DN15	SST	with valve	1046474

Tab. 10: Spare parts kits types 07120, 07220, 04350

Liquid ends	Wetted materials	Remark	Order no.
FM 350 - DN25	PVT	-	1046475
FM 350 - DN25	TTT	-	1077574
FM 350 - DN25	SST	-	1046476
FM 350 - DN25	SST	with valve	1046477

Tab. 11: Spare parts kits for integrated relief valve

Spare parts kit	for material version	Seals	Order no.
ETS relief valve 4 bar	PVT/SST	FPM-A / EPDM	1031199
ETS relief valve 7 bar	PVT/SST	FPM-A / EPDM	1031200
ETS relief valve 10 bar	PVT	FPM-A / EPDM	1031201
ETS relief valve 16 bar	SST	FPM-A / EPDM	1031203

21.2 Physiological safety

Spare parts kits

Tab. 12: Scope of delivery with PVF material version

1 x diaphragm, 2 x valve balls, 1 x suction valve complete, 1 x discharge valve complete
1 x elastomer sealing set (EPDM)
2 x ball seat housings, 2 x ball seat discs, 4 x composite seals
1x sealing washer (for bleed valve or relief valve)

Tab. 13: Scope of delivery with SSF material version

1 x diaphragm, 2 x valve balls
2 x cover rings
4 x composite seals
1x sealing washer (for bleed valve or relief valve)

Ordering information

Wear parts of Sigma/ 2

Tab. 14: Spare parts kits PVF (liquid ends)

Liquid end	Types 16050, 16090, 16130	Types 07120, 07220, 04350
FM 130 - DN 15	1046472	-
FM 350 - DN 25	-	1046475

Tab. 15: Spare parts kits SSF (liquid ends)

Liquid end	Types 16050, 16090, 16130	Types 07120, 07220, 04350
FM 130 - DN 15	1046473	-
FM 130 - DN 15 with 2 complete valves	1046474	-
FM 65 - DN 10	-	1046476
FM 65 - DN 10 with 2 complete valves	-	1046477

Wetted materials

Tab. 16: Wetted materials – "Physiologically safe with regard to wetted materials" design

Material version	Liquid end	Suction / pressure connector	Seals* / ball seat	Balls	Integrated bleed valve or relief valve
PVF	PVDF	PVDF	PTFE / PVDF	Ceramic / glass **	PVDF / EPDM
SSF	Stainless steel 1.4404	Stainless steel 1.4581	PTFE / PVDF	Stainless steel 1.4404	Stainless steel / EPDM

* Diaphragm is PTFE-coated; seals are PTFE composite seals

PTFE: FDA No. 21 CFR §177.1550

PVDF: FDA No. 21 CFR §177.2510

** with 07120, 07220, 04350

22 Declaration of Conformity for Machinery

For pumps without explosion protection:

In accordance with DIRECTIVE 2006/42/EC OF THE EUROPEAN PARLIAMENT AND OF THE COUNCIL, Appendix I, BASIC HEALTH AND SAFETY REQUIREMENTS, section 1.7.4.2. C.

We,

- ProMinent GmbH
- Im Schuhmachergewann 5 - 11
- D - 69123 Heidelberg, Germany,

hereby declare that the product specified below complies with the relevant basic health and safety requirements of the Directive, on the basis of its functional concept and design and in the version distributed by us.

Any modification to the product not approved by us invalidates this declaration.

Tab. 17: Excerpt from the Declaration of Conformity

Designation of the product:	Metering pump, Sigma product range
Product type:	S2Ba _____ § 0 ____ with characteristics § = "M" or "N" or "R" or "S" or "T" or "V" or "Z"
Serial number:	see nameplate on the unit
Relevant directives:	Machinery Directive (2006/42/EC) Compliance with the protection targets of the Low Voltage Directive 2014/35/EU according to Appendix I, No. 1.5.1 of the Machinery Directive 2006/42/EC EMC Directive (2014/30/EU)
Harmonised standards applied, in particular:	EN ISO 12100:2010 EN 809:1998 + A1:2009 + AC:2010 EN 61000-6-2:2005 + AC:2005, EN 61000-6-4:2007 + AC:2011+ AC:2012
Date:	20.04.2016

You can download the Declaration of Conformity from www.prominent.com.

23 Declaration of Incorporation for Machinery

For pumps without explosion protection:

In accordance with DIRECTIVE 2006/42/EC OF THE EUROPEAN PARLIAMENT AND OF THE COUNCIL, Appendix I, BASIC HEALTH AND SAFETY REQUIREMENTS, section 1.7.4.2. C.

We,

- ProMinent GmbH
- Im Schuhmachergewann 5 - 11
- D - 69123 Heidelberg, Germany,

hereby declare that the product specified below complies with the relevant basic health and safety requirements of the Directive, on the basis of its functional concept and design and in the version distributed by us. Technical documents were produced in line with Appendix VII Part B.

Any modification to the product not approved by us invalidates this declaration.

Tab. 18: Excerpt from the Declaration of Conformity

Designation of the product:	Metering pump without motor, product range Sigma
Product type:	S2Ba _____ § 0__ with characteristics § = "1" or "2" or "3" or "4" or "5"
Serial number:	see nameplate on the unit
Relevant directives:	Machinery Directive (2006/42/EC) Compliance with the protection targets of the Low Voltage Directive 2014/35/EU according to Appendix I, No. 1.5.1 of the Machinery Directive 2006/42/EC
Harmonised standards applied, in particular:	EN ISO 12100:2010 EN 809:1998 + A1:2009 + AC:2010
Only start up the pump when it has been established that the machine into which the pump has been installed corresponds to the provisions of the Machine Directive.	
Date:	20.04.2016

You can download the Declaration of Conformity from www.prominent.com.

24 Declaration of Conformity for ATEX Machinery

For pumps with explosion protection:

We,

- ProMinent GmbH
- Im Schuhmachergewann 5 - 11
- DE - 69123 Heidelberg, Germany,

hereby declare that the product specified below complies with the relevant basic health and safety requirements of the Directive, on the basis of its functional concept and design and in the version distributed by us.

Any modification to the product not approved by us invalidates this declaration.

Tab. 19: Excerpt from the Declaration of Conformity

Designation of the product:	Metering pump, Sigma product range, Design for use in areas at risk of explosion in accordance with the ATEX Directive (2014/34/EU)
Product type:	S2Ba_____ § \$ __ with characteristics § = "L" or "P" and \$ = "1" or "2"
Serial number:	see nameplate on the unit
Relevant directives:	ATEX Directive (2014/34/EC) Machinery Directive (2006/42/EC) Compliance with the protection targets of the Low Voltage Directive 2014/35/EU according to Appendix I, No. 1.5.1 of the Machinery Directive EMC Directive (2014/30/EU)
Harmonised standards applied, in particular:	EN ISO 80079-36:2016, EN ISO 80079-37:2016, EN ISO 12100:2010, EN 809:1998 + A1:2009 + AC:2010 EN 61000-6-2:2005 + AC:2005, EN 61000-6-4:2007 + AC:2011
Ex specification of the entire system:	II 2G Ex h IIC T3 Gb X for \$ = "1" II 2G Ex h IIC T4 Gb X for \$ = "2" X*: max. media temperature 90 °C Ambient temperature -10 °C ... +40 °C
Date:	16.11.2018

* With regard to "Special conditions" - refer also to the "Safety chapter" - "Safety information for ATEX designs" - "Special conditions for ATEX".

You can download the Declaration of Conformity from www.prominent.com.

The Declarations of Conformity, the EC type-examination certificates and the operating instructions for the individual components are also enclosed with the pump.

25 Declaration of Conformity for ATEX Machinery

For pumps with explosion protection:

In accordance with DIRECTIVE 2006/42/EC OF THE EUROPEAN PARLIAMENT AND OF THE COUNCIL, Appendix I, BASIC HEALTH AND SAFETY REQUIREMENTS, section 1.7.4.2. C.

We,

- ProMinent GmbH
- Im Schuhmachergewann 5 - 11
- D - 69123 Heidelberg, Germany,

hereby declare that the product specified below complies with the relevant basic health and safety requirements of the Directive, on the basis of its functional concept and design and in the version distributed by us. Technical documents were produced in line with Appendix VII Part B.

Any modification to the product not approved by us invalidates this declaration.

Tab. 20: Extract from the Declaration of Incorporation

Designation of the product:	Metering pump without motor, product range Sigma Design for use in areas at risk of explosion in accordance with the ATEX Directive (2014/34/EC)
Product type:	S2Ba _____ § A ____ with characteristics § = "1" or "2" or "3" or "4" or "5"
Serial number:	see nameplate on the unit
Relevant directives:	ATEX Directive (2014/34/EU) Machinery Directive (2006/42/EC) Compliance with the protection targets of the Low Voltage Directive 2014/35/EU according to Appendix I, No. 1.5.1 of the Machinery Directive 2006/42/EC
Harmonised standards applied, in particular:	EN ISO 80079-36:2016 EN ISO 80079-37:2016 EN ISO 12100:2010 EN 809:1998 + A1:2009 + AC:2010
Only start up the pump when it has been established that the machine into which the pump has been installed corresponds to the provisions of the Machine Directive.	
EX-designation:	II 2G Ex h IIC T4 Gb X X: max. medium temperature 90 °C Ambient temperature -10 °C ... + 40 °C
Assess the ignition risk when combining the pump and motor.	
Date:	16.11.2018

* "Special conditions" - also refer to the chapter entitled "Special conditions for ATEX".

You can download the Declaration of Conformity from www.prominent.com.

The Declarations of Conformity, the EC type-examination certificates and the operating instructions for the individual components are also enclosed with the pump.

26 Index

A

Actuator	66
Ambient conditions	64
Applied harmonised standards	83, 84
Assembly	30
ATEX designs	14

C

Capacity	69
Cleaning valves	51
Climate	65
Connector size	62, 63
Contact	66
Control drive	66
Control elements	26

D

Declaration of Conformity	81, 83
Declaration of Incorporation	82, 84
Decommissioning	60
Diagrams	69
Diaphragm	28
Diaphragm rupture sensor	26, 66
Dimensional drawings	70
Direction of rotation	38
Discharge valve	28
Disposal	61
Dosing head	28
Dosing rate	62, 63
Draining the liquid end	61

E

Electrical data	65
Emergency	13
EU Declaration of Conformity	83
EU Declaration of Incorporation	84
External fan	38, 65

F

Form	68
------	----

G

Gear oil	68
Guard plate	65

H

Hygienic pump head	32
--------------------	----

I

Identification of safety notes	9
--------------------------------	---

Identity code	5
Identity code versions for areas at risk from explosion	83, 84
Information in the event of an emergency	13
Installation	33
Installation height	65
IP	65

L

Leakage hole	48
Liquid end	28

M

Maintenance	47
Materials	64
Metering pumps without integral relief valve	36
Modified	68
motor	68
Motor	38

N

Namur sensor	20, 66, 67
--------------	------------

O

Overview of equipment	26
-----------------------	----

P

Pacing relay	40, 67
PCT	65
Potential equalisation	72
Precision	63
Pump capacity	62, 63

Q

Qualification of personnel	10
----------------------------	----

R

Relief valve	26, 34
Repair	51
Replacing the diaphragm	53
Reproducibility	63
Return pipe	36

S

Safety chapter	9
Safety information for ATEX designs	14
Scope of delivery	25
Shipping weight	64
Sound pressure level	14, 68
Spare parts	68
Special conditions	14

Index

Start up	42
Storage	25
Storage and transport temperature	64
Stroke actuator	66
Stroke control drive	66
Stroke length	44
Stroke length adjustment control	68
Stroke sensor	40, 67
Suction lift	62, 63
Suction valve	28

T

Technical data	62, 68
Temperature monitoring	65
Temperatures	64
Transport	25
Troubleshooting	57

U

Unpacking	25
---------------------	----

W

Warning sign	9
Weight	64
Wetted materials	64



ProMinent GmbH
Im Schuhmachergewann 5-11
69123 Heidelberg
Germany
Telephone: +49 6221 842-0
Fax: +49 6221 842-419
Email: info@prominent.com
Internet: www.prominent.com

985908, 5, en_GB