

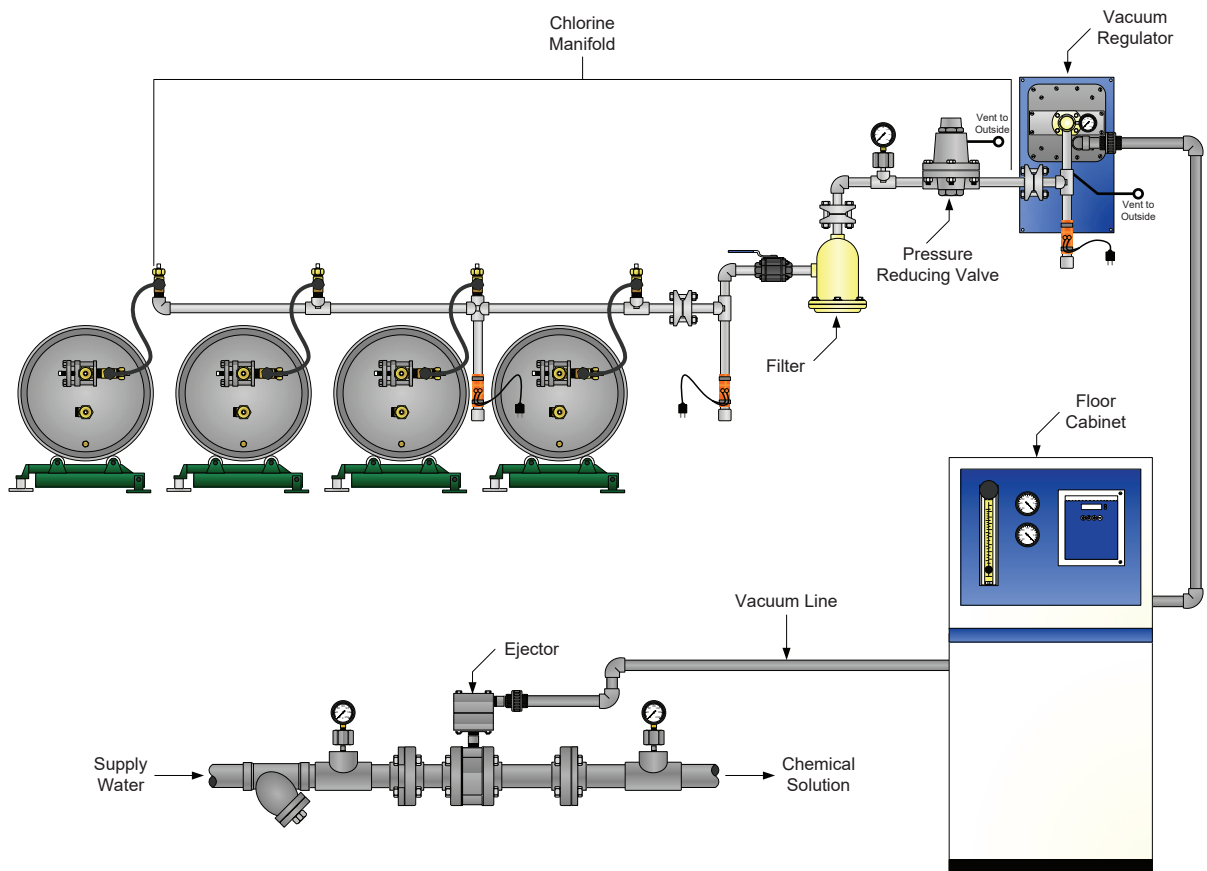

Gas Chlorination Systems Series 3000 High Capacity and Floor Cabinets

Instruction Manual



The information contained in this manual was current at the time of printing. The most current versions of all Hydro Instruments manuals can be found on our website: www.hydroinstruments.com

Hydro Instruments Series 3000 High Capacity

Table of Contents

I. Safety Information (Ton Containers)	3
II. Design and Installation Notes	4
III. System Installation.....	5
IV. Chlorination System Vacuum Test	9
V. Start Up of Chlorination.....	9
VI. Shut Down Procedure.....	9
VII. Rate Valve Operation.....	10
VIII. Troubleshooting	10
APPENDIX: Repair and Preventative Maintenance	12
A-1. Servicing the Vacuum Regulator.....	12
A-2. Remote Meter	13
A-3. Ejector Nozzle and Throat	13
A-4. Ejector Check Valve.....	14
A-5. Switchover Module.....	14
Tables:	
1. Gas Chlorination Equipment Torque Specifications	2
2. Vacuum Line Piping	6
Figures:	
1A. System Example: Automatic Feed Control	3
1B. Gas Flow Direction.....	4
2. System Example: Manual Feed Control	7
3. System Example: Vacuum Switchover with Automatic Feed Control	7
4. System Example: Electronic Changeover.....	8
5. Example Flow Meter: RMH-1000-CL2	34
6. Reading Edge for Various Float Shapes.....	34
Exploded Views and Bills of Material.....	15-55

Table 1

Hydro Instruments Gas Feed Equipment Torque Specifications

Item	Min. Inch/lbs.	Max. Inch/lbs.
Yoke bolts	20	25
Body bolts	20	25
Vacuum fittings	15	20
Item	Min. Foot/lbs.	Max. Foot/lbs.
Inlet assembly flange bolts	20	25

SECTION I: SAFETY INFORMATION (TON CONTAINERS)

TAKE CARE WITH CHLORINE!

1. Valve protection covers must be on ton container valves **before they are ever moved**.
2. The ton container should be levelly placed on a pair of trunions.
3. Always place container so valves are in vertical alignment and use only the top valve (which is the gas valve).
BOTTOM VALVE IS LIQUID—DO NOT USE.
4. For best operation and safety, the ton container and vacuum regulator should be protected from the elements and direct sunlight.
5. **NEVER** apply heaters or heat lamps directly on a chlorine container.

IMPORTANT NOTE:

Whenever possible, the use of chlorine gas manifolds should be avoided. Because manifolds contain pressurized chlorine gas, they pose an increased risk of a chlorine gas leak. When the system design necessitates the use of manifolds extreme care should be taken with regards to their installation, operation and maintenance.

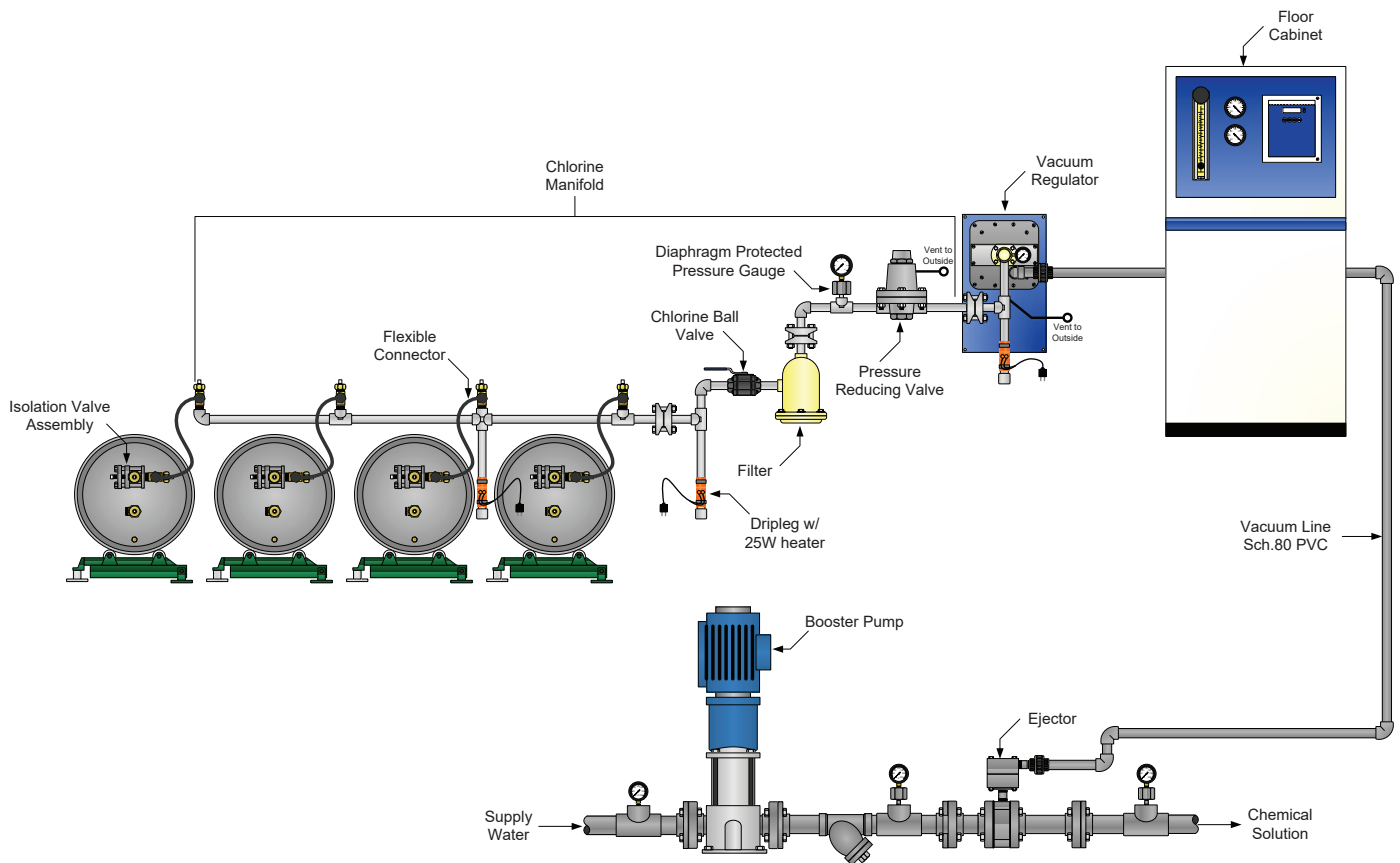

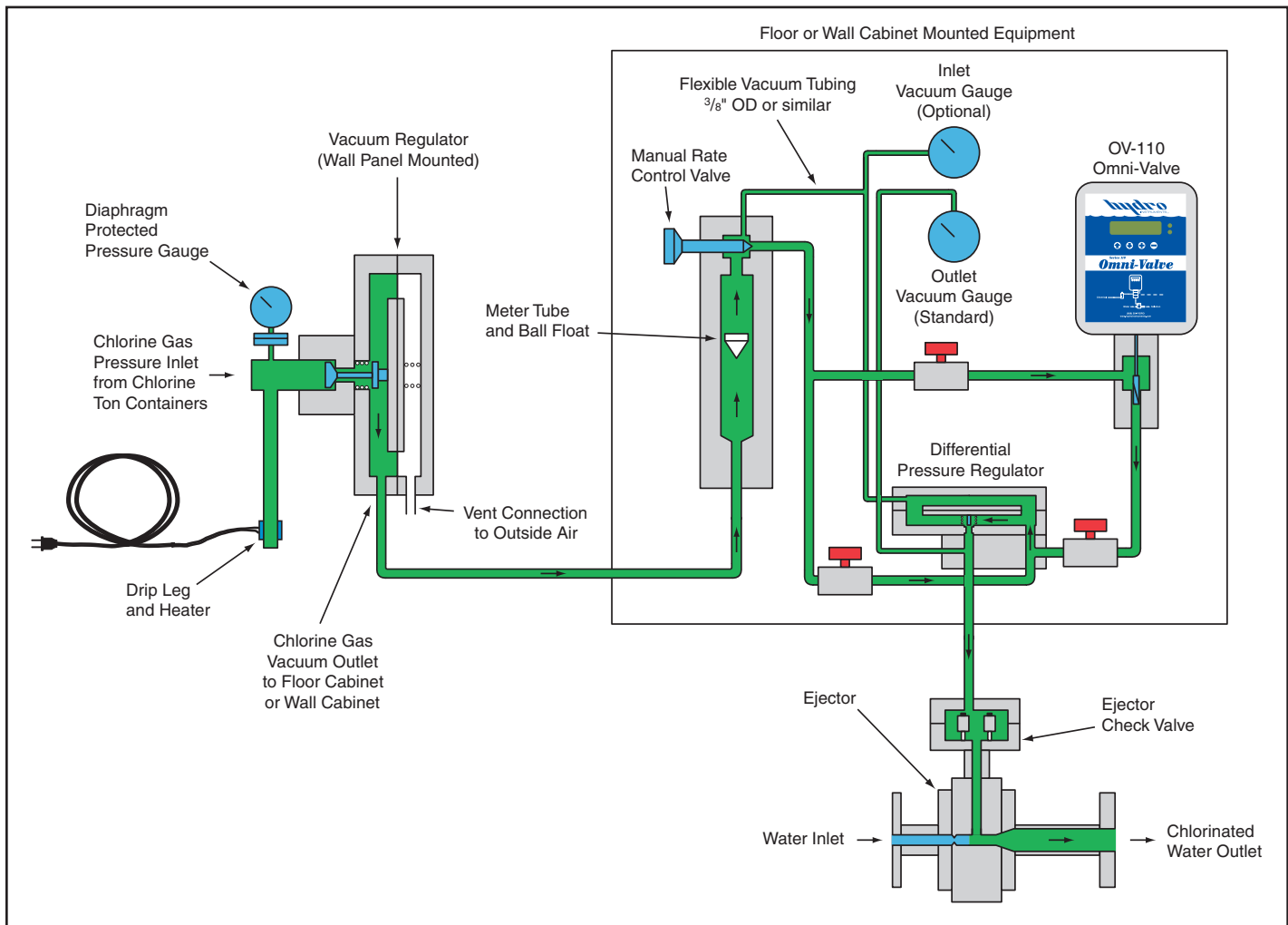

FIGURE 1A – SYSTEM EXAMPLE: AUTOMATIC FEED CONTROL
 FIGURE 1B – GAS FLOW DIRECTION

SECTION II: DESIGN AND INSTALLATION NOTES

1. The **“all vacuum” system** means that system will shut off at the vacuum regulator inlet valve, should the vacuum line be broken, if water is stopped for any reason, or if the vacuum regulator is physically damaged.

2. Choosing a **vacuum regulator feed capacity:**

VACUUM REGULATOR SIZE SHOULD BE ON MAXIMUM POSSIBLE FLOW.

Imperial Units:

$$\begin{array}{rclcl} \text{GPM} & \times & 0.012 & \times & (\text{PPM}) \text{ Dosage} & = & \text{PPD} \\ \text{Gallons Per Minute} & & & & \text{Parts Per Million} & & \text{Pounds Per Day (Cl}_2\text{)} \end{array}$$

Example: 30,000 GPM x 0.012 x 3 PPM = 1080 PPD

In this example a 2000 PPD vacuum regulator would be adequate.

Metric Units:

$$\begin{array}{rcccl} \text{M}^3/\text{Hr} & \times & \text{(PPM) Dosage} & = & \text{Gr/Hr} \\ \text{Cubic Meters Per Hour} & & \text{Parts Per Million} & & \text{Grams Per Hour (Cl}_2\text{)} \end{array}$$

3. **TOTAL BACK PRESSURE** is the pressure in the pipeline to be chlorinated plus the friction losses in the solution line between the ejector and the point of injection at the pipeline. Ejectors capable of operating with back pressures up to 150 PSIG (10 bar) are available depending on the ejector model and capacity.
4. It is preferable that the ejector be located near the point of solution injection in order to eliminate the need for **solution lines**. Friction losses in the solution line will **increase the ejector back pressure**. Friction losses can be reduced by increasing the solution line internal diameter and limiting the number of flow restrictions and turns. Also, be sure that the solution line material is resistant to **the highly concentrated chlorine mixture**. **Avoid solution lines wherever possible**.
5. Schedule 80 PVC pipe is recommended to carry the chlorine under vacuum from the vacuum regulator to the ejector.

SECTION III: SYSTEM INSTALLATION

(I) INSTALLATION OF FLANGED EJECTOR (Refer to Figure 1A)

1. Installation of Ejectors:
 - a. The water inlet and outlet connections are 2" or 3" flanged, four bolt, 150 lb., Van Stone style in Schedule 80 PVC.
 - b. The shorter end is the water inlet (nozzle side) and the longer end is the chlorinated solution outlet.
 - c. Install both flanges carefully with new flange gaskets from Hydro Instruments.
2. Testing of ejector. (*Note: The vacuum regulator should not be connected and the chlorine container valves should remain closed.*)
 - i. Piping hook up to ejector (Refer to Figure 1A):
 - a. Ejector should be installed down stream at a sufficient distance so that chlorinated water is not re-circulated through the booster pump.
 - b. On the water inlet side to the ejector nozzle the following should be installed: a water inlet valve, Y-strainer, and a pressure gauge.
 - ii. Testing for sufficient pump pressure to operate ejector. Also checking that booster pump (if applicable) operating in the proper direction.

Note 1: Ejector must have some back pressure to prevent jetting. (Jetting causes loss of vacuum)

Note 2: When injecting into a contact chamber a tee should be installed on the solution line with a vacuum breaker to prevent siphoning.

 - a. If operating with city water pressure (no booster pump), open the water inlet valve to the

- ejector and feel for suction (with your hand) at the gas intake of the ejector.
- b. If using a booster pump, open the water inlet valve to the ejector and the pressure gauge should indicate a sufficient boost. (See ejector curves at the end of this manual.) If pump is operating in proper direction there should be a strong vacuum at the gas intake of the ejector. Feel for suction (with your hand) at the gas intake of the ejector.
 - c. If the ejector has tested satisfactorily continue on to the next step (Installation of Floor Cabinet and/or Vacuum Regulator).

(II) INSTALLATION OF FLOOR CABINET

1. **Location:** Select a location for installation of the floor cabinet where it will be protected from unauthorized personnel. The location should be selected to permit easy access to both the front and rear of the cabinet for operation and maintenance procedures. The cabinet is not suitable for outdoor installation.
2. **Connections:** Schedule 80 PVC union connections are provided with all Hydro Instruments floor cabinets for the vacuum inlet from the vacuum regulator and vacuum outlet to the ejector. The size of the union is dependant on the capacity of the floor cabinet. Refer to Table 2 for connection sizing. Threaded connections should be prepared with PTFE (Teflon) tape prior to assembly.
3. **Wiring:** For wiring installation consult the Series OV-110 or CV-230 operation and maintenance manual.

(III) INSTALLATION OF VACUUM REGULATOR

1. **Mounting:** Install the vacuum regulator panel vertically on a wall in a location convenient to the

TABLE 2: Vacuum Line Piping

Capacity (Max)	Piping Size
2,000 PPD (40 kg/hr)	1"
8,000 PPD (160 kg/hr)	1½"
10,000 PPD (200 kg/hr)	2"

NOTE: Ensure threaded connections are clean and prepared with adequate PTFE (Teflon) tape or other suitable thread sealant. Do not over tighten PVC threaded connections.

gas manifold piping. The drip leg must extend downward.

2. **Manifolds:** A ¾" forged steel union is provided for connection to the gas manifolds. Ensure this union is tightened evenly but not excessively after connections have been made.
3. **Vacuum Connections:** The size of the vacuum connection is determined by the capacity of the vacuum regulator. Schedule 80 PVC piping is recommended for vacuum lines of 1,000 PPD (20 kg/hr) or higher.
A threaded Schedule 80 PVC union is provided with the vacuum regulators in the appropriate size. Connect vacuum outlet on vacuum regulator to either the remote meter panel bottom union, a gas inlet union on the switchover module or the gas inlet on the floor cabinet (depending on the system arrangement). See Figures 2 and 3 for details.

FIGURE 2 – SYSTEM EXAMPLE: MANUAL FEED CONTROL

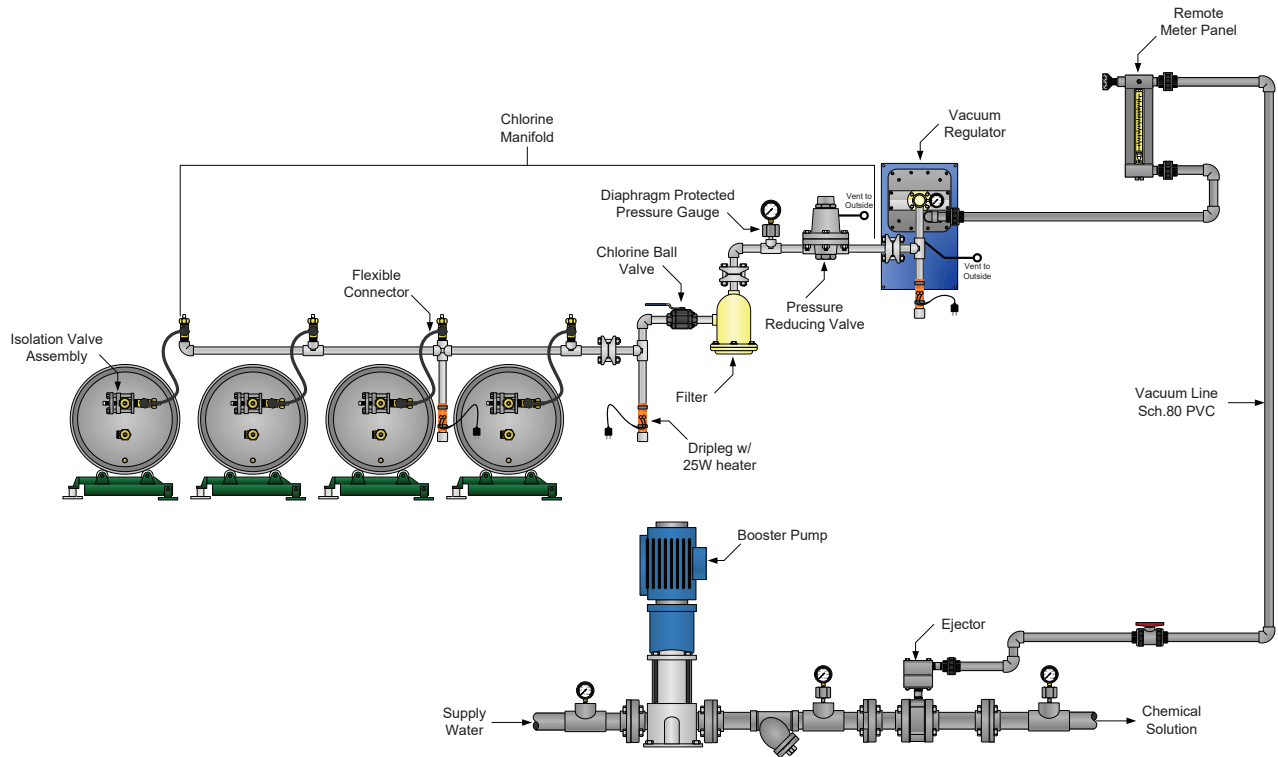
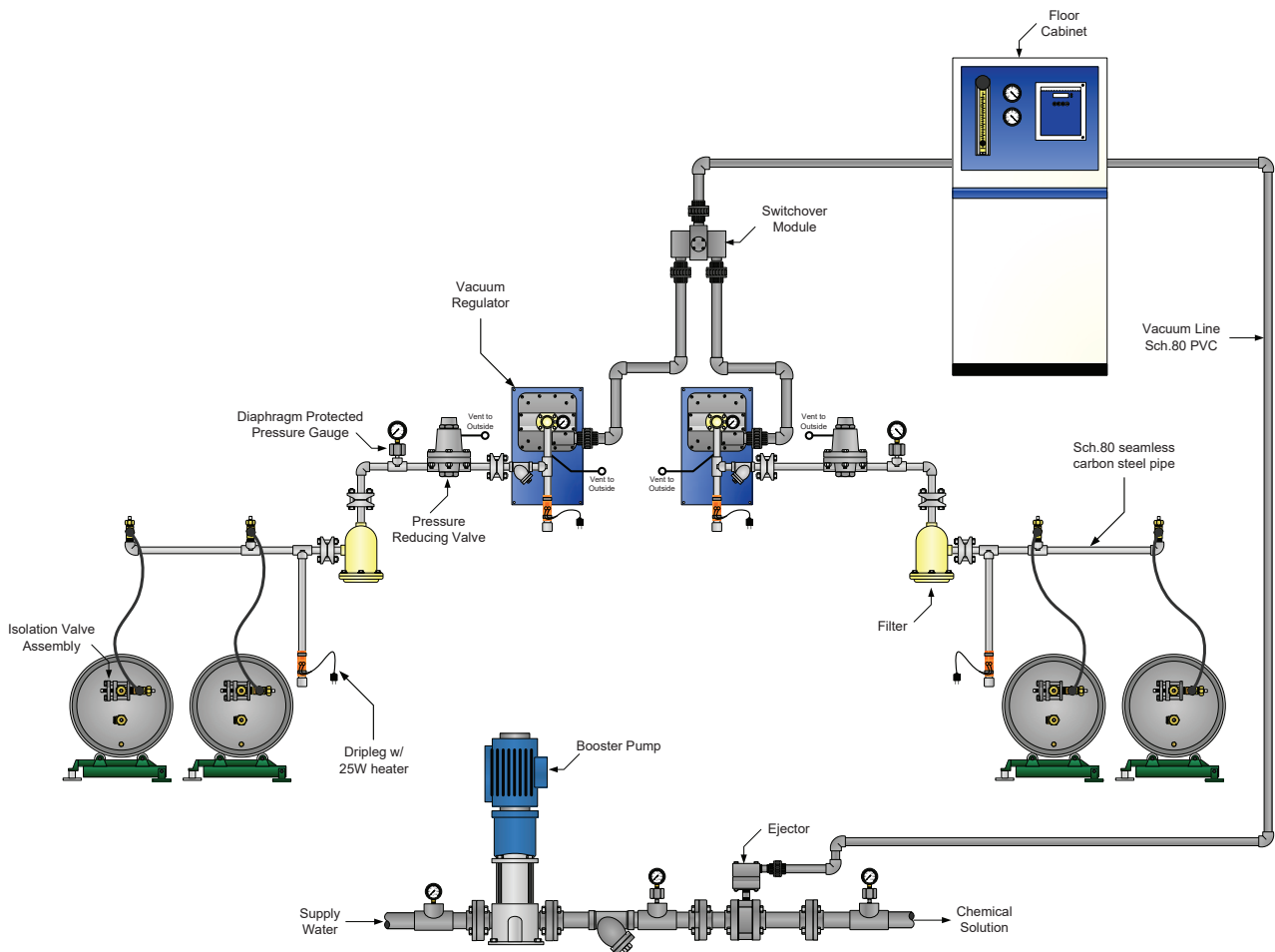
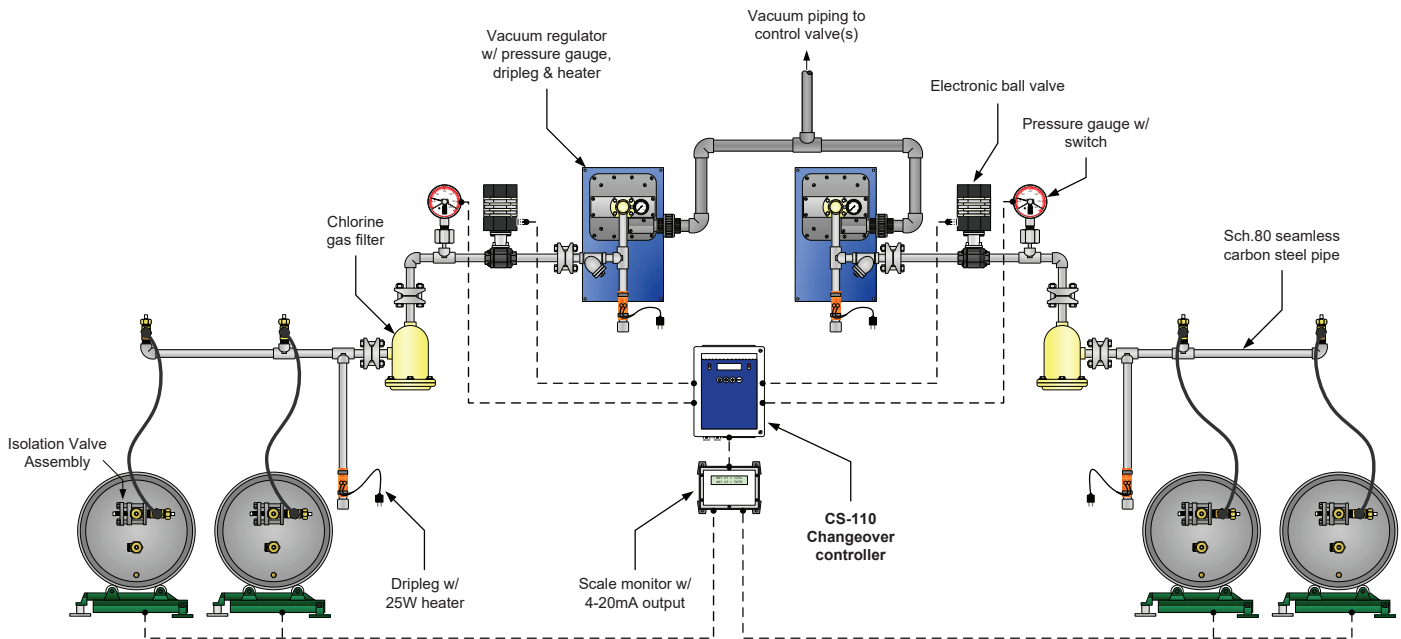

FIGURE 3 – SYSTEM EXAMPLE: VACUUM SWITCHOVER WITH AUTOMATIC FEED CONTROL



4. **Vent Tubing Connections:** All Hydro vacuum regulators are equipped with a vent tubing connection for directing and venting chlorine gas to a safe location. Tubing is also provided. Connect the appropriate tubing (provided) to the vent connection on the vacuum regulator vent fitting. Run the vent tubing to a safe location (outside the building). Whenever possible, avoid low spots in the vent tubing and direct the tubing down from the vacuum regulator to keep moisture from accumulating or entering the vacuum regulator. Install an insect screen (provided) on the outside end of the vent tubing.
5. **Drip Leg Heater:** Prior to startup of the system or prior to placing any new ton container on suction, the drip leg heater(s) must be powered for at least 15 minutes. This will ensure proper evapo-

FIGURE 4 – SYSTEM EXAMPLE: ELECTRONIC CHANGEOVER



ration of trapped chlorine liquid takes place. This heater must always be powered during operation.

(IV) SWITCHOVER MODULES AND REMOTE METERS (Refer to Figure 3)

1. **Switchover modules:** (Gas flow is from bottom/side to top from one side only at a time)
 - a. Connect the two lines from the vacuum regulators to the side unions.
 - b. Connect the single line out to the remote meter(s) to the top union.

2. **Remote Meters:** (Gas flow is from bottom to top through the tube)
 - a. Connect the input line (from the vacuum regulator or switchover module) to the lower union.
 - b. Connect the output line (to the ejector) to the upper union.

Figure 4: Electronic changeover system. Pressure switches indicate when the pressure falls in the supply containers in use indicating that they are nearly empty. Then the controller closes the valve in the line for that set of containers and opens the other valve. Before removing the empty containers, the container valves must be closed and the valves opened to allow the full evacuation of the depleted manifold.

SECTION IV: CHLORINATION SYSTEM VACUUM TEST

1. **Do Not** open chlorine container valve until vacuum test is satisfactorily completed.
 - a. Vacuum Test
With the chlorine container(s) still closed, start the ejector booster pump and the meter tube float should drop to the bottom within about ten seconds. If the float continues to bounce there is a leak. At this time the rate valve on the remote meter should be open two or three turns. If a leak is indicated, inspect all piping connections and gaskets.
 - b. Turn off water supply to ejector.
 - c. Wait 5 to 10 minutes with water supply off. The vacuum gauge should maintain the indicated vacuum.
 - d. If the system is vacuum tight proceed to the next step.
 - e. Disconnect a union in the vacuum line to allow air to enter the system. Reconnect union.

SECTION V: START UP OF CHLORINATION

Material necessary: A small plastic squeeze bottle (provided), 1/3 full of household ammonia, for detecting chlorine leaks. When ammonia fumes contact chlorine gas a visible white smoke-like gas is produced. (Wipe up any splashed liquid ammonia.)

1. Open chlorine container valves 1/4 turn and **close immediately**.
2. Squeeze ammonia bottle (ammonia fumes, not liquid) at all pressurized areas. If no fumes appear the seals are tight and it is OK to proceed to the next step. (*NOTE: The fumes are best observed against a dark background.*)
3. Open chlorine container valve(s) 1 turn, leave open, and **recheck for chlorine leaks**. (1 turn open of the container valve is all that's required. In an emergency you can shut it off quickly and safely. The wrench should always remain on the container valve while container valve is open.)
4. Turn remote meter rate valve knob to the right (clockwise) until shut (for startup). This will prevent the float from "jumping" during startup.
5. Turn on water supply or booster pump to ejector and set rate valve to desired flow rate. Refer to page 23 for the proper float reading edge.
6. Rate valve is not a shut off valve: it is a flow rate control only. **To shut off chlorine feed close the chlorine container valves.**
7. For automatic control valve start-up refer to the OV-110 or CV-230 O & M Manual.

SECTION VI: SHUT DOWN PROCEDURE

1. Close the chlorine container valves while the water supply to the ejector is still on.
2. Wait for the float to rest at bottom of meter tube.
3. Break vacuum by loosening a union (preferably nearest the vacuum regulator) in the vacuum line and retighten. (Repeat at least 2 times for more complete removal of gas from the system.)
4. Shut down the water supply to the ejector.

This procedure of shut down must be followed before any connections to the manifold are opened.

SECTION VII: RATE VALVE OPERATION

PREVENTATIVE MAINTENANCE NOTE: Rate valves that are not exercised frequently may experience a build up of a white powdery substance which precipitates out of the chlorine gas. In order to avoid this build up, which can cause the rate valve to become stuck in place, it is recommended that the rate valve be periodically exercised. See Appendix Section A-II for rate valve maintenance instructions.

MANUAL OPERATION OF SYSTEM

Two true union ball valves are used to isolate the automatic control valve for manual feed rate control when maintenance or repair is necessary. These valves are accessible from the rear of the floor cabinet.

SECTION VIII: TROUBLESHOOTING

(I) PRESSURIZED LEAKS

1. Pressurized chlorine leaks are a safety hazard to life and equipment and should be corrected immediately. When searching for this type of leak there are basic safety rules to follow.
 - a. Air breathing pack should be readily available and personnel should know how to use it properly.
 - b. Exhaust fan switch should be located near outside entrance with an additional alternate outside switch appropriately located.
 - c. Chlorine valve wrenches should remain on the container valves whenever they are open.
 - d. Plastic squeeze bottle $\frac{1}{3}$ full of household ammonia.
 - e. Buddy system used (two people capable of operating system).
2. If a leak is detected the following should be checked first:
 - a. The **inlet section** of the vacuum regulator.
 - i. Tighten the hex filter cap.
 - b. The **chlorine gas manifold pipe system** from vacuum regulators back to the ton containers.
 - c. **Chlorine container valve packing.**
 - i. Tighten the container valve with care, not excessively! Close the valve if problem persists

- and notify your chlorine supplier.
- ii. If valve is the problem try to move container with a high degree of safety to an outside location. (**Never** attempt to place container in water as this will only increase the leak and the container may float to the surface.)
- d. Chlorine leaking out the vent due to **the inlet safety shut off valve** having dirt or damage on the valve seat.
- i. Close the **chlorine container valves**.
 - ii. Wait until the metering float drops to zero on the flow tube.
 - iii. Turn off water supply to ejector.
 - iv. Now remove the vacuum regulator inlet valve assembly.
 - v. See Appendix Section A-I for inlet safety shut off valve servicing instructions.
 - vi. After servicing and remounting vacuum regulator with a new lead gasket, pull a vacuum test **before** you turn on the chlorine container valves. **See “Chlorination System Vacuum Test” (Section IV).**

(II) NO CHLORINE FEED

Possible causes:

1. No vacuum being produced by ejector.
 - a. Disconnect piping at the ejector intake and place your hand on it; you should feel a suction.
 - b. If you feel no suction (vacuum) check in this order:
 - i. **Nozzle (See Appendix Section A-III):** Turn off water supply and remove nozzle from ejector.
 - (1) It may be clogged with a stone or other foreign matter. Flush out or run pipe cleaner through only.
 - (2) If there is a build-up of rust, iron, or manganese, place the nozzle in a Muriatic acid for five minutes and rinse with water. If you see any buildup inside, you may find it necessary to clean the nozzle on a preventative maintenance schedule.
 - ii. **Inlet Water Supply.**
 - iii. Reduced city water pressure.
 - iv. Y strainer requires cleaning.
 - v. Booster pump cavitating (lost its prime).
 - vi. Booster pump insufficient boost due to wear or single phasing due to loss of one leg of power.
2. Chlorine flow blocked at vacuum regulator inlet assembly.

- a. The **chlorine gas filter could be clogged.**
- 3. **Out of chlorine.**
 - a. The scale would read 2000 lbs. (1000 kg) lighter than when container was new.
 - b. Meter tube float would be at zero.

(III) CHECK VALVE FAILURE (Water in flow tube and vacuum lines)

- 1. Cause – Ejector check valve failure. Possible causes of ejector check valve failure:
 - a. Objects or material preventing closure of ejector check valve.
 - b. Failure of ejector check valve o-ring.
 - c. Failure of ejector check valve diaphragm.
- 2. Corrective Action
 - a. Follow Appendix Section A-IV to repair ejector check valve.
 - b. Disassemble and dry vacuum regulator(s), remote meter(s), and switchover module.
 - c. Follow Section IV vacuum test procedure before resuming chlorination.

APPENDIX: REPAIR AND PREVENTATIVE MAINTENANCE

Hydro Instruments vacuum regulators require little service when operated according to instructions. The following are recommended maintenance instructions.

NOTE: All Hydro Instruments systems come with a three year limited warranty. Hydro Instruments does repair and refurbish used units at the factory. The repaired and retested units are shipped within 48 hours of arrival at the factory with a one year warranty.

Guidelines for Preventative Maintenance: See below for detailed instructions.

- 1. Service Rate Valves every 4 months. (See Section A-II)
- 2. Replace Rate Valve O-ring every 12 months. (See Section A-II)
- 3. Service Flow Meter every 12 months. (See Section A-II)
- 4. Service Ejector every 12 months. (See Sections A-III and A-IV)
- 5. Inspect and clean vacuum piping every 12-18 months. Replace as needed.
- 6. Thoroughly inspect and clean chlorine gas pressure manifold piping every 12 months. Replace any corroded or damaged parts as needed.

CAUTION: Use all recommended precautions when using chemicals of any kind, including goggles, gloves, face shields, etc.

After any of the listed repair procedures, it is necessary to go through the Start-Up (including vacuum test) again!

SECTION A-I: SERVICING THE VACUUM REGULATOR

- 1. **Inlet Filter:** The inlet filter consists of a Silver filter screen (VRH-133-000) located under the hexagonal filter cap (VRH-229-000) in the inlet assembly. This cap is sealed to the inlet assembly by means of a lead inlet gasket (GAH-LED-124).
 - a. Remove the filter cap and pull the inlet filter out of the assembly.

- b. Clean the screen by submerging and agitating in hot soapy water.
 - c. Dry the screen thoroughly with compressed air prior to reassembly.
 - d. The lead inlet gasket should be replaced whenever servicing or replacing the inlet filter Silver screen.
 - e. Tighten the filter cap to seal the lead gasket. Test carefully to ensure there is no leak before resuming operation.
2. **Venting Gas:** Venting gas is caused by the inlet safety valve failing to completely isolate the pressurized chlorine gas during stand-by operation. It is indicated by chlorine gas leaking from the end of the vent tubing. This can occur in a switchover system to the unit not on suction or in a single-regulator layout when the system is idle.

The inlet safety valve can leak because of debris or buildup on the stem or seat preventing the valve from fully shutting or by damage to the stem or seat caused by passing debris. Maintaining gas filters is the best way to prevent venting.

3. **Servicing the Inlet Safety Valve:** To repair a venting vacuum regulator, it is necessary to disassemble the inlet capsule, clean the Valve Plug (VRH-141-000) and replace the inlet seat and adapter (VRH-15082-000). O-rings should be replaced whenever maintenance is performed on the inlet capsule.
- a. To service the inlet safety valve, remove the inlet assembly (VRH-1841-000) from the vacuum regulator back-plate by unscrewing the four hex bolts (BTH-STA-139). This will expose the inlet capsule.
 - b. Once the inlet capsule has been removed, carefully disassemble by unscrewing the Valve Plug (VRH-141-000) from the vent screw (VRH-182-000). This will require two flathead screwdrivers. Take care when disassembling, as the inlet capsule is spring-loaded.
 - c. Replace the inlet seat and adapter (VRH-15082-000), o-rings and clean the inlet plug prior to reassembly.
See drawing on page 15.

4. **Inspection of the Inlet Assembly and Drip Leg:** As with pressurized manifolds, it is necessary to periodically inspect the drip leg and inlet assembly for corrosion and damage. Because these parts contain pressurized chlorine gas, extreme care should be taken with regards to their maintenance.

The interior surfaces of the inlet assembly (VRH-1841-000) should be carefully inspected whenever the inlet capsule is serviced. If wear or corrosion is found, this part should be replaced.

If a leak is found on the drip leg piping, the piping should be disassembled, cleaned and inspected. If wear or corrosion is found, the damaged part should be replaced. Extreme care should be taken when assembling threaded piping connections.

NOTE: After performing any maintenance on pressurized piping connections, a pressure test should be conducted with air prior to reinstalling in the chlorine gas system.

SECTION A-II: REMOTE METER

NOTE: Carefully follow shutdown procedures before performing this repair.

1. Rate Valve

- a. Fully unscrew and remove the rate valve from the meter assembly.
- b. Inspect and clean the two Rate Valve O-Rings and replace them if necessary.
- c. Clean out any visible debris or corrosion found in the meter or on the rate valve.

2. Meter Tube Assembly

- a. Carefully remove the protective covers.
- b. While carefully preventing the flow tube from falling, unscrew the meter inlet plug to allow the meter tube to be removed.

NOTE: For the RMH-4000-CL2 the bottom water block must be removed to remove the meter tube.

- c. Inspect and clean the top and bottom o-rings or gaskets. Replace them if necessary.
- d. Clean the tube, float and stops carefully before reassembly.

SECTION A-III: EJECTOR NOZZLE AND THROAT

NOTE: Carefully follow shutdown procedures before performing this repair.

1. Be sure to isolate the ejector on both intake and outlet sides to prevent leakage of water or gases.
2. Disconnect the vacuum intake connection.
3. Disassemble both the intake and outlet water connection flanges and remove it from the water pipeline.
4. Remove the flanges from the Ejector Body.
5. Unthread the nozzle and throat from the Ejector Body. Take care not to damage the threaded portion.
6. Inspect and clean the nozzle and throat interior. Soaking in Muriatic Acid is recommended if scale build-up is present. Replace them if necessary.

SECTION A-IV: EJECTOR CHECK VALVE

NOTE: Carefully follow shutdown procedures before performing this repair.

1. Remove the four bolts holding the two Check Valve Body parts together.
2. Lift the Check Valve Top Body away from the Check Valve Bottom Body.
3. The Check Valve O-Ring should be replaced. When installing a new Check Valve O-Ring, carefully ensure it is evenly seated in the groove. Lubricating the new O-Ring with Fluorolube is recommended.
4. Inspect the Check Valve Diaphragm for damage (holes, cracking, etc.). If necessary, unscrew the diaphragm nut and bolt, preferably using a Spanner wrench and tongue and groove pliers. Use care not to snap the nut. The Check Valve Diaphragm should be replaced every 12 to 24 months.
5. Replace the spring only if it is damaged.
6. Replace any parts necessary and reassemble.

SECTION A-V: SWITCHOVER MODULE

NOTE: Carefully follow shutdown procedures before performing this repair.

1. Disconnect all three vacuum connections and remove the switchover module.
2. Unscrew the BTH-STA-125 screws that hold the Body Flanges to the Center Body.
3. Inspect and clean the DIH-116-000 Diaphragms. If any imperfections are found or if these have been in place for 12 months or longer, they should be replaced.
4. Inspect and clean the OH-VIT-217 O-Rings. Replace if necessary.
5. Remove and clean out any debris or corrosion.
6. Manually check to ensure that the mechanism can be switched in both directions without excessive force and without binding.

Inlet Capsule Assembly
VRH-5919-000

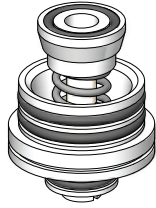

Requires this matching part:
Diaphragm Bolt
VRH-335-000

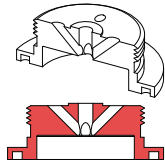

Inlet Capsule Assembly
VRH-5919-000-1

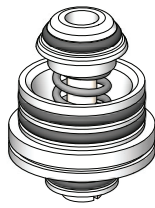

Requires this matching part:
Diaphragm Bolt
VRH-335-000-1

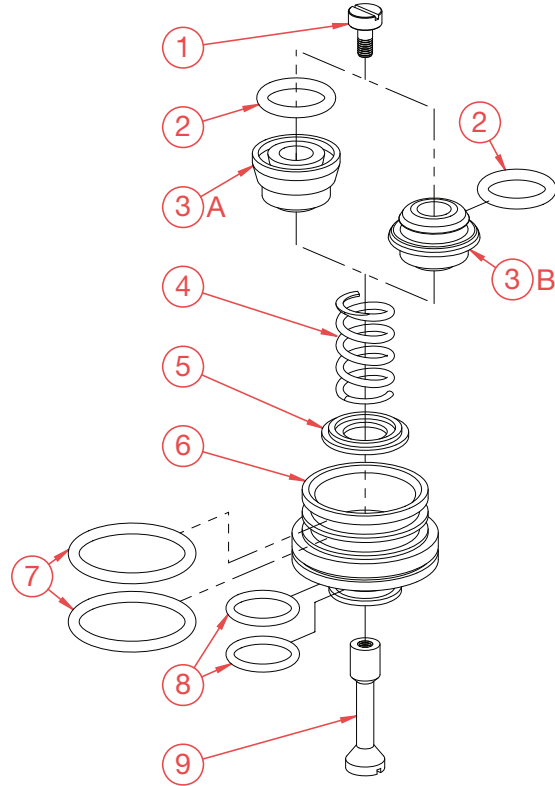
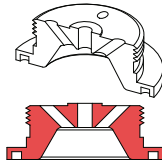

Item No.	Description	Quantity	Part No.
1	Vent Screw (Silver)	1	VRH-182-000
2	^{PM} O-Ring	1	OH-VIT-209
3A	Vent Plug (included in VRH-5919-000)	1	VRH-2318-000
3B	Vent Plug (included in VRH-5919-000-1)	1	VRH-2318-000-1
4	Spring (Tantalum)	1	SPH-109-000
5	Spring Retainer (Hastelloy)	1	VRH-181-000
6	^{PM} Seat and Adapter	1	VRH-15082-000
7	^{PM} O-Ring	2	OH-VIT-220
8	^{PM} O-Ring	2	OH-VIT-116
9	Valve Stem (Silver)	1	VRH-141-000
^{PM}	Part & Maintenance Kit	1	Refer to table below

PM components included with other parts in the following PM Kits:

Vacuum Regulator	PM Kit No.
VRH-2000-CL2	KTH-2000-VRW
VRH-8000-CL2	KTH-8000-VRW
VRH-10000-CL2	KTH-10000-VRW
WR-10000-CL2	KTH-10000-WR



Date: 2022-12-02-v1
EXPLODED VIEW & BOM
Dwg. No. VRH-5919-000
and VRH-5919-000-1

INLET CAPSULE ASSEMBLY

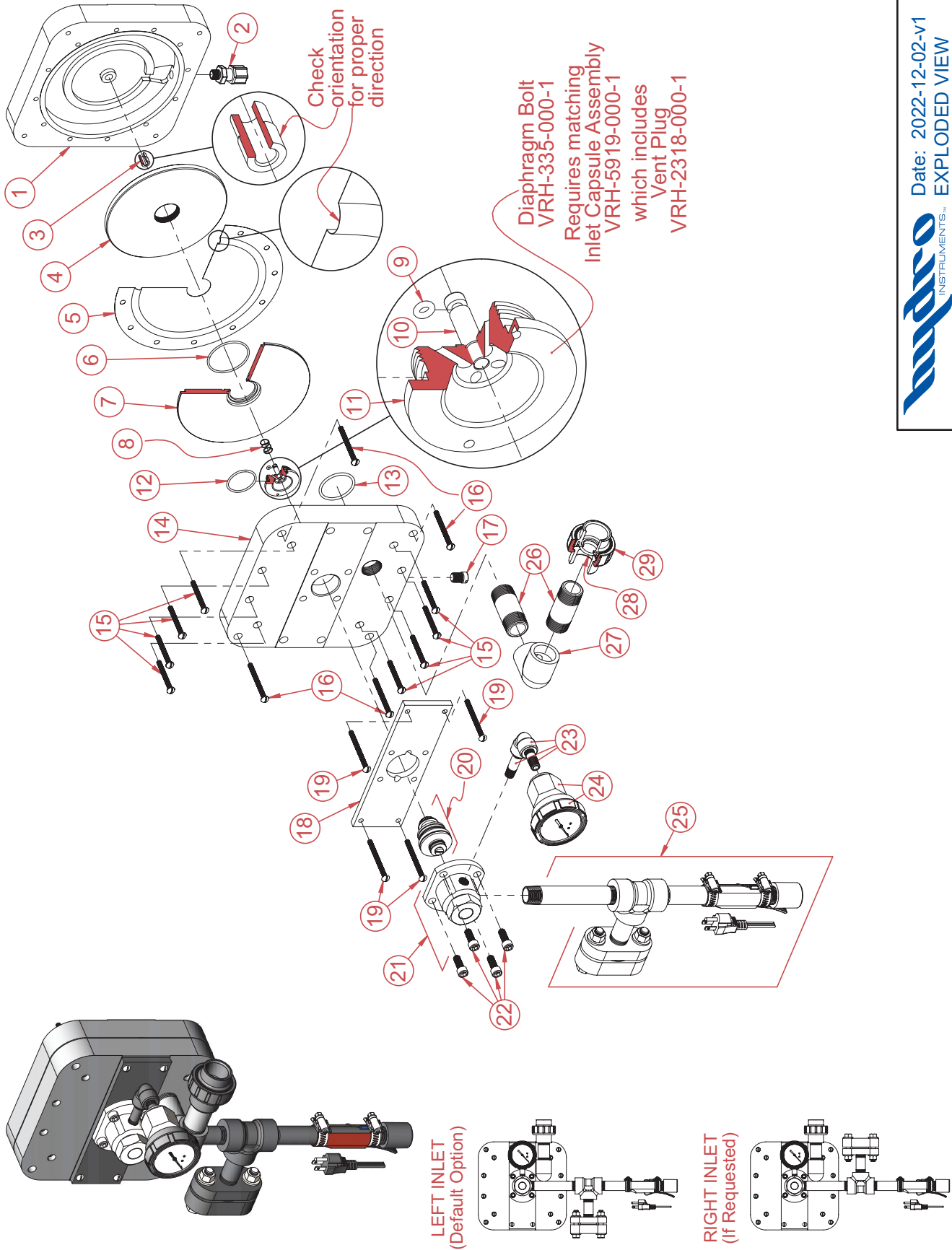

Item No.	Description	Quantity	Part No.	Item No.	Description	Quantity	Part No.
1	Front Body	1	VRH-12704-000	21	* Inlet Adapter Assembly	1	*VRH-5968-000
2	^{PM} 1/4" NPT 1/2" Tube Tubing Connector	1	BKF-84	22	3/8-16 x 1" Socket Head Cap Screw	4	BTH-STA-139
3	‡ Pin Guide	1	VRH-12664-001	23	Gauge Tube Assembly	1	VRH-1150-000
4	Diaphragm Front Plate	1	VRH-333-000		Nipple, 1/4" x 2" (Carbon Steel)		
5	Set of Two Diaphragms	1	DIH-110-000		Nipple, 1/4" x 1 1/2" (Carbon Steel)		
					Elbow, 1/4" (Carbon Steel)		
6	^{PM} O-Ring	1	OH-VIT-141	24	Diaphragm Protected Pressure Gauge Assembly	1	PVR-300-EW
7	Diaphragm Back Plate	1	VRH-764-000				
8	Relief Spring	1	SPH-100-000	25	* Inlet Drip Leg and Union Assembly	1	*VRH-1091-000
9	^{PM} O-Ring	1	OH-VIT-006	26	1" NPT 3" PVC Nipple	2	RH-306-000
10	Guide Pin	1	DM-201	27	1" NPT 90° PVC Elbow	1	
				28	^{PM} O-Ring (for 1" PVC Union)	1	OH-VIT-215
11	Diaphragm Bolt	1	VRH-335-000-1	29	1" PVC Union Assembly	1	U-4475
12	^{PM} O-Ring	1	OH-VIT-128				
13	^{PM} O-Ring	1	OH-VIT-224	^{PM}	Part & Maintenance Kit	1	KTH-2000-VRW
14	Back Body	1	VRH-311-000	*	See separate drawings for Exploded View and BOM		
15	1/4-20 x 2 1/4" RHMS (Monel)	8	BTH-STA-129	‡	VRH-12664-001 must be installed in the correct orientation. Smaller outside diameter into the front body first. Incorrect installation could cause venting.		
16	1/4-20 x 2 3/4" RHMS (Monel)	4	BTH-STA-125				
17	1/4" NPT Plug	1	PLH-108-250				
18	Back Plate	1	VRH-1397-000				
19	1/4-20 x 3" RHMS (Monel)	4	BTH-STA-279				
20	* Inlet Capsule Assembly	1	*VRH-5919-000-1				

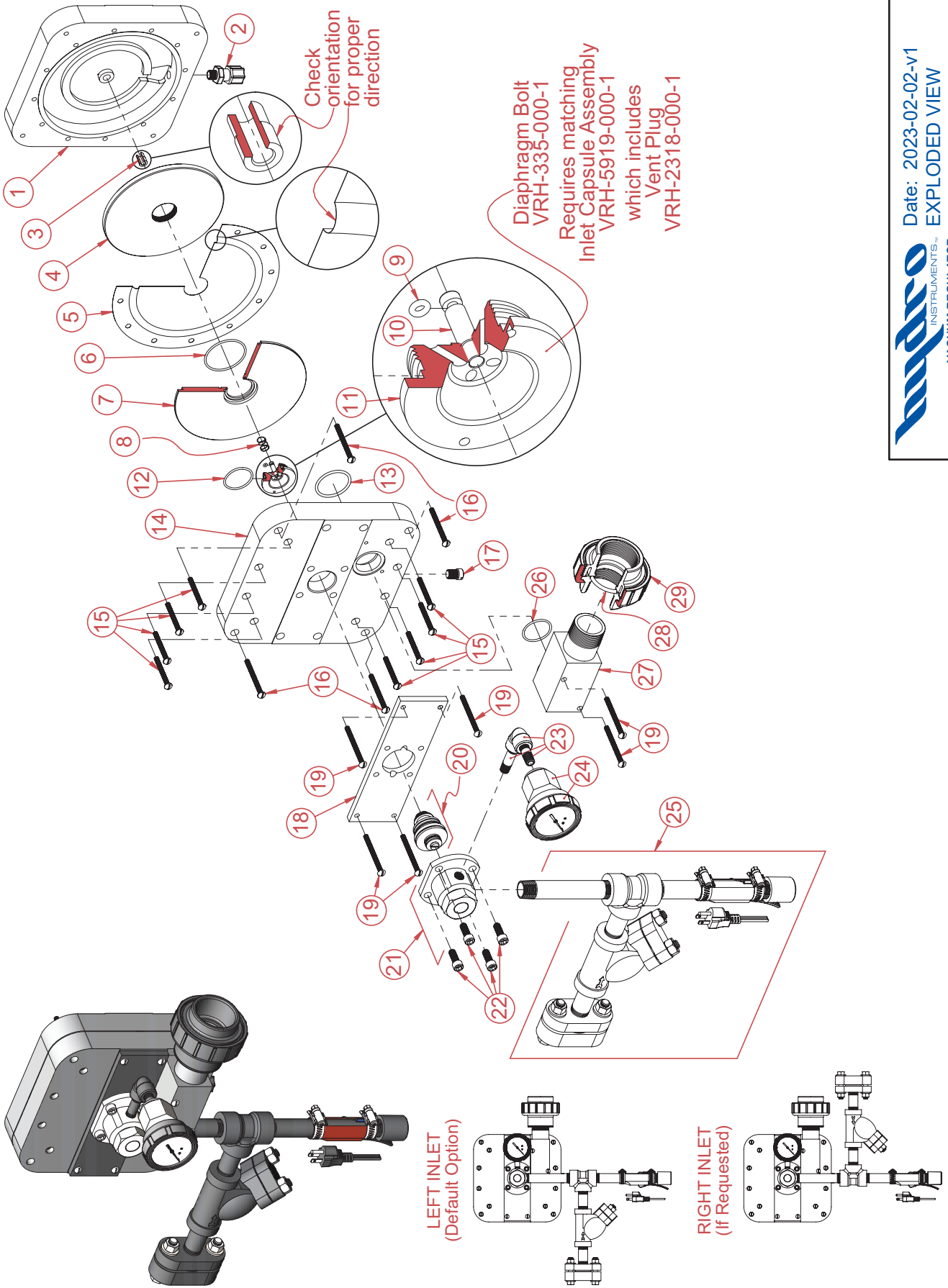

Item No.	Description	Quantity	Part No.	Item No.	Description	Quantity	Part No.
1	Front Body	1	VRH-12704-000	21	* Inlet Adapter Assembly	1	*VRH-5968-000
2	^{PM} 1/4" NPT 1/2" Tube Tubing Connector	1	BKF-84	22	3/8"-20-16 x 1" Socket Head Cap Screw	4	BTH-STA-139
3	‡ Pin Guide	1	VRH-12664-001	23	Gauge Tube Assembly	1	VRH-1150-000
4	Diaphragm Front Plate	1	VRH-333-000		Nipple, 1/4" x 2" (Carbon Steel)		
5	Set of Two Diaphragms	1	DIH-110-000		Nipple, 1/4" x 1 1/2" (Carbon Steel)		
					Elbow, 1/4" (Carbon Steel)		
6	^{PM} O-Ring	1	OH-VIT-141	24	Diaphragm Protected Pressure Gauge Assembly	1	PVR-300-EW
7	Diaphragm Back Plate	1	VRH-764-000				
8	Relief Spring	1	SPH-100-000	25	* Inlet Drip Leg and Union Assembly with Y-Strainer	1	*VRH-1191-000
9	^{PM} O-Ring	1	OH-VIT-006	26	^{PM} O-Ring	1	OH-VIT-130
10	Guide Pin	1	DM-201	27	Outlet Block	1	VRH-273-000
11	Diaphragm Bolt	1	VRH-335-000-1	28	^{PM} O-Ring (for 1.5" PVC Union)	1	OH-VIT-328
12	^{PM} O-Ring	1	OH-VIT-128	29	1.5" PVC Union Assembly	1	U-4298
13	^{PM} O-Ring	1	OH-VIT-224				
14	Back Body	1	VRH-391-000	^{PM}	Part & Maintenance Kit	1	KTH-8000-VRW
15	1/4-20 x 2 1/4" RHMS (Monel)	8	BTH-STA-129	*	See separate drawings for Exploded View and BOM		
16	1/4-20 x 2 3/4" RHMS (Monel)	4	BTH-STA-125	‡	VRH-12664-001 must be installed in the correct orientation. Smaller outside diameter into the front body first. Incorrect installation could cause venting.		
17	1/4" NPT Plug	1	PLH-108-250				
18	Back Plate	1	VRH-1397-000				
19	1/4-20 x 3" RHMS (Monel)	6	BTH-STA-279				
20	* Inlet Capsule Assembly	1	*VRH-5919-000-1				



Date: 2023-02-02-v1
 BILL OF MATERIALS
 DWG. No. VRH-8000-CL2, BOM

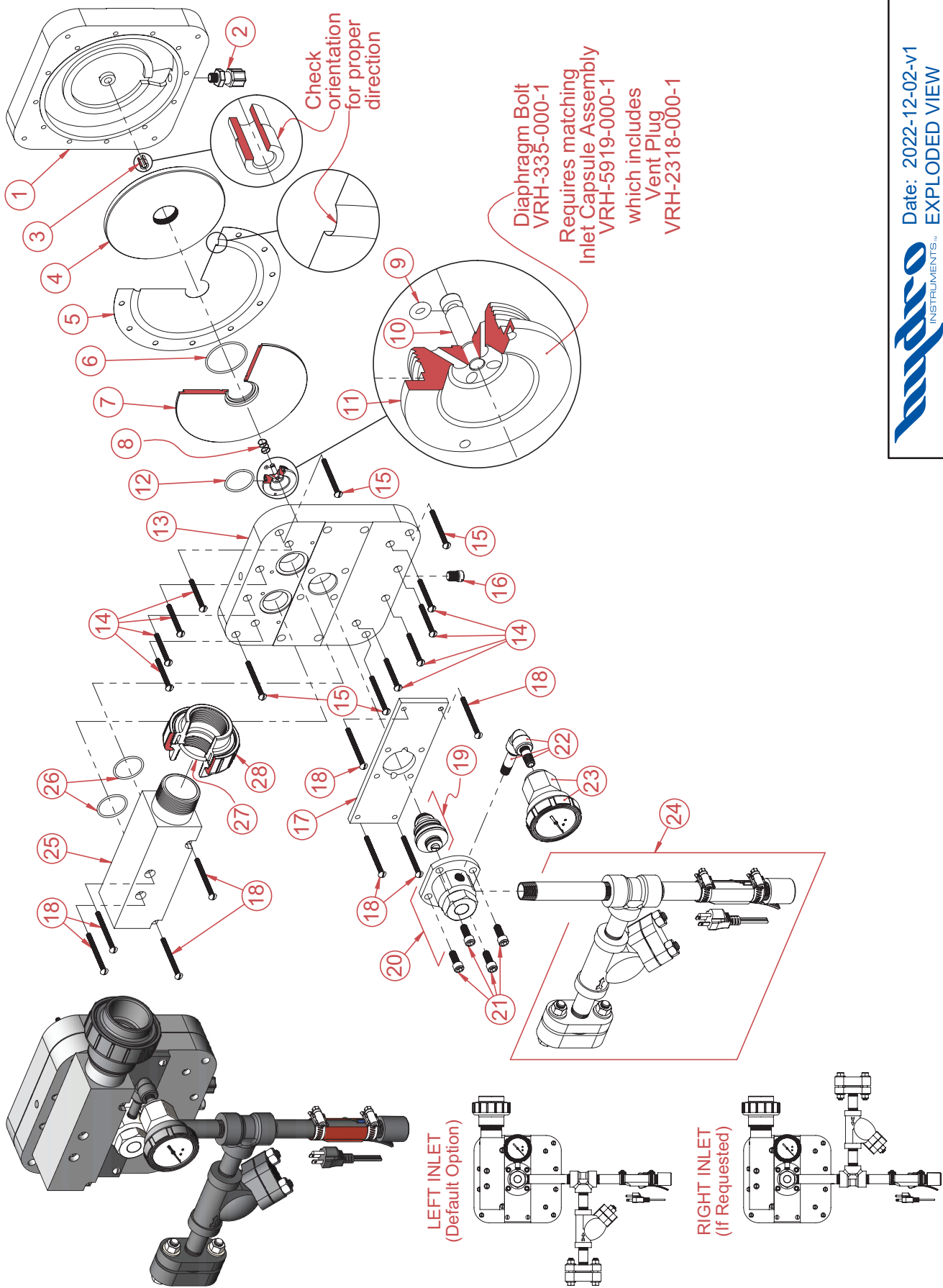

Item No.	Description	Quantity	Part No.	Item No.	Description	Quantity	Part No.
1	Front Body	1	VRH-12704-000	25	Outlet Flow Tube Assembly	1	VRH-1429-000
2	^{PM} ¼" NPT ½" Tube Tubing Connector	1	BKF-84	26	^{PM} O-Ring	2	OH-VIT-130
3	‡ Pin Guide	1	VRH-12664-001	27	^{PM} O-Ring (for 2" PVC Union)	1	OH-VIT-330
4	Diaphragm Front Plate	1	VRH-333-000	28	2" PVC Union Assembly	1	BM-4993
5	Set of Two Diaphragms	1	DIH-110-000	^{PM}	Part & Maintenance Kit	1	KTH-10000-VRW
6	^{PM} O-Ring	1	OH-VIT-141	*	See separate drawings for Exploded View and BOM		
7	Diaphragm Back Plate	1	VRH-764-000	‡	VRH-12664-001 must be installed in the correct orientation. Smaller outside diameter into the front body first. Incorrect installation could cause venting.		
8	Relief Spring	1	SPH-100-000				
9	^{PM} O-Ring	1	OH-VIT-006				
10	Guide Pin	1	DM-201				
11	Diaphragm Bolt	1	VRH-335-000-1				
12	^{PM} O-Ring	1	OH-VIT-128				
13	Back Body	1	VRH-1409-000				
14	¼-20 x 2¼" RHMS (Monel)	8	BTH-STA-129				
15	¼-20 x 2¾" RHMS (Monel)	4	BTH-STA-125				
16	¼" NPT Plug	1	PLH-108-250				
17	Back Plate	1	VRH-1397-000				
18	¼-20 x 3" RHMS (Monel)	4	BTH-STA-279				
19	* Inlet Capsule Assembly	1	VRH-5919-000-1				
20	* Inlet Adapter Assembly	1	VRH-5968-000				
21	¾-16 x 1" Socket Head Cap Screw	4	BTH-STA-139				
22	Gauge Tube Assembly Nipple, ¼" x 2" (Carbon Steel) Nipple, ¼" x 1½" (Carbon Steel) Elbow, ¼" (Carbon Steel)	1	VRH-1150-000				
23	Diaphragm Protected Pressure Gauge Assembly	1	PVR-300-EW				
24	* Inlet Drip Leg and Union Assembly with Y-Strainer	1	VRH-1191-000				

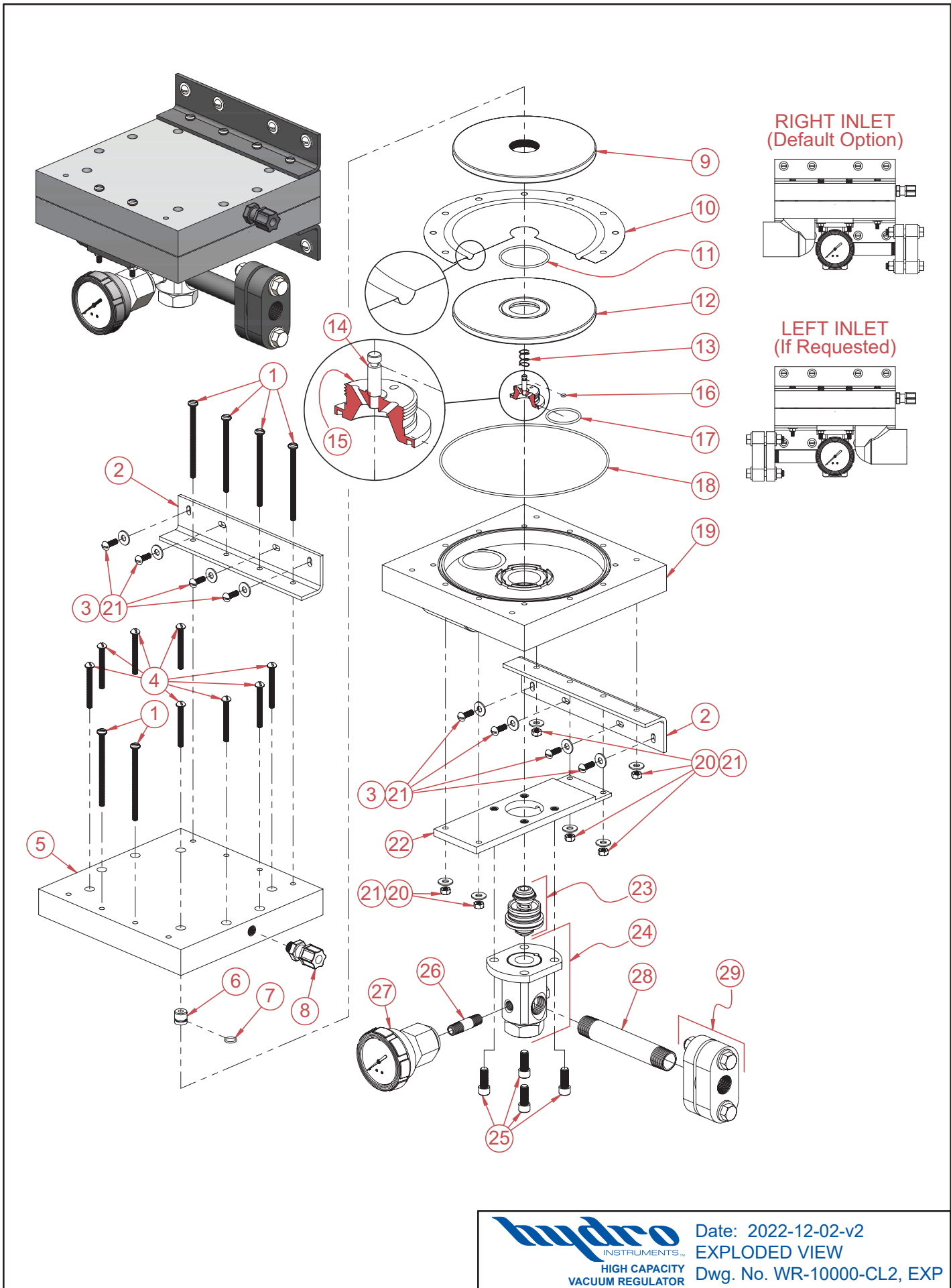

Item No.	Description	Quantity	Part No.
1	¼-20 x 4" PHMS (Monel)	6	BTH-STA-414
2	Wall Bracket	2	VRH-1399-000
3	¼-20 x ¾" RHMS (Monel)	8	BTH-STA-189
4	¼-20 x 2¼" RHMS (Monel)	8	BTH-STA-129
5	Front Body	1	VRH-12705-000
6	Pin Guide	1	FB-204
7	^{PM} O-Ring	1	OH-VIT-014
8	^{PM} ¼" x ½" Tubing Vent Fitting	1	BKF-84
9	Diaphragm Front Plate	1	VRH-333-000
10	Set of Two Diaphragms	1	DIH-110-000
11	^{PM} O-Ring	1	OH-VIT-141
12	Diaphragm Back Plate	1	VRH-764-001
13	Relief Spring	1	SPH-100-000
14	Guide Pin	1	DM-201
15	Diaphragm Bolt	1	VRH-335-000-1
16	^{PM} O-Ring	1	OH-VIT-006
17	^{PM} O-Ring	1	OH-VIT-128
18	^{PM} O-Ring	1	OH-VIT-172
19	Back Body	1	VRH-312-000
20	¼-20 Finished Hex Nut (Monel)	6	BTH-STA-412
21	¼" Flat Washer (Monel)	14	BTH-STA-413
22	Back Plate	1	VRH-1398-000
23	* Inlet Capsule Assembly	1	*VRH-5919-000-1
24	* Inlet Adapter Assembly	1	*VRH-5978-000
25	⅜-16 x 1" Socket Head Cap Screw	4	BTH-STA-139
26	2" Gauge Tube (¼" NPT 2" Nipple, Monel)	1	VRH-1140-000
27	Diaphragm Protected Compound Gauge	1	PVR-300-EW
28	¾" NPT 6" Seamless Carbon Steel Pipe Nipple (Schedule 80, ASTM A 106 Grade B)	1	
29	¾" NPT Steel Union	1	AH-1461
29	¾" to 1" NPT Steel Union	1	
29	1" NPT Steel Union	1	AH-1462
^{PM}	Part & Maintenance Kit	1	KTH-10000-WR
	PM Kit includes additional components, shown in drawings VRH-5919-000-1 and VRH-5978-000		
*	See separate drawings for Exploded View and BOM		



Date: 2022-12-02-v2
 BILL OF MATERIALS
 Dwg. No. WR-10000-CL2, BOM

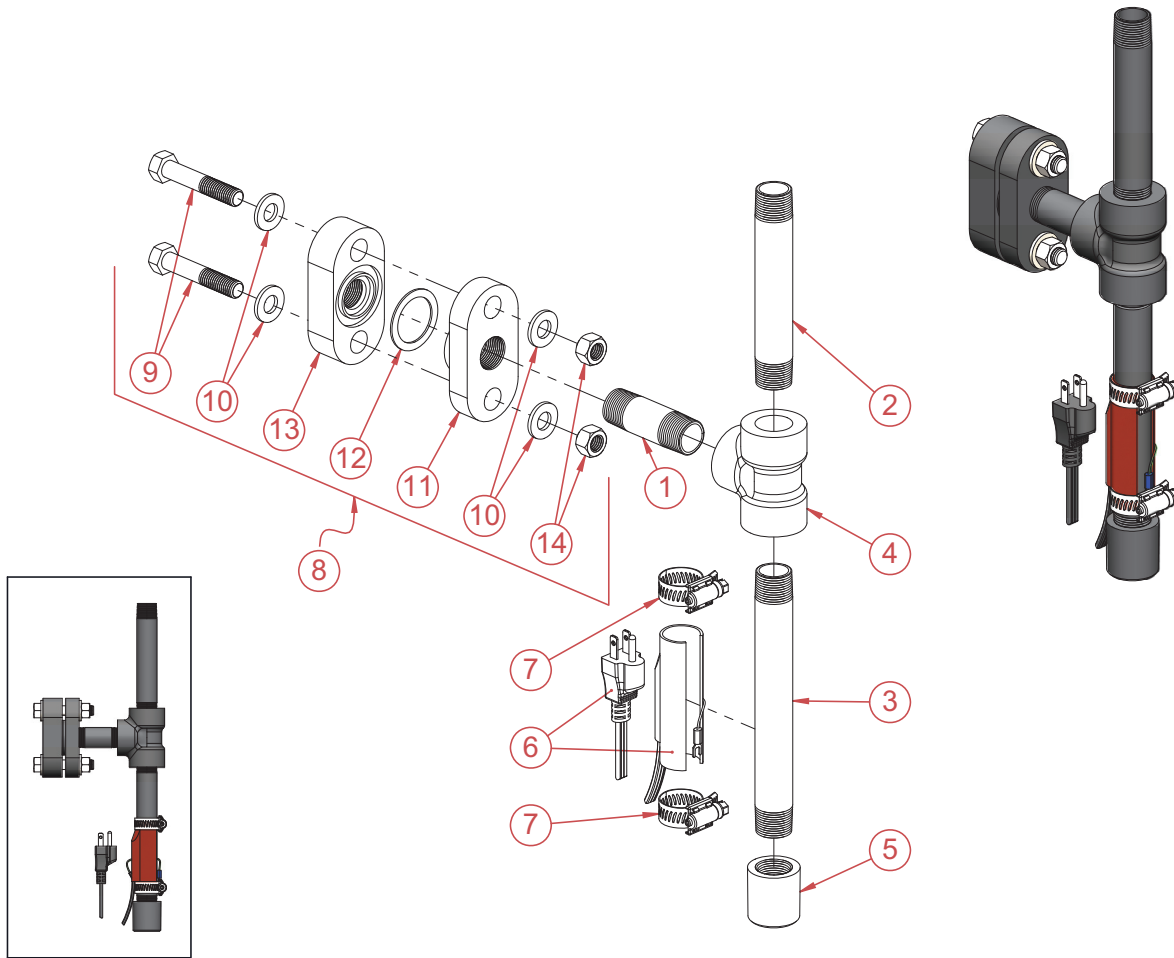

Item No.	Description	Quantity	Part No.	Item No.	Description	Quantity	Part No.
1	3/4" NPT 3" Seamless Carbon Steel Pipe Nipple (Schedule 80, ASTM A 106 Grade B)	1		7	Heater Clamp (two included with heater)	2	C-12
2	3/4" NPT 6" Seamless Carbon Steel Pipe Nipple (Schedule 80, ASTM A 106 Grade B)	1		8	3/4" NPT Steel Union	1	AH-1461
3	3/4" NPT 8" Seamless Carbon Steel Pipe Nipple (Schedule 80, ASTM A 106 Grade B)	1		8	3/4" to 1" NPT Steel Union	1	
4	3/4" NPT Seamless Carbon Steel Pipe Tee (Schedule 80, ASTM A 106 Grade B)	1		9	HC Union Bolt	2	
5	3/4" NPT Seamless Carbon Steel Pipe End Cap (Schedule 80, ASTM A 106 Grade B)	1		10	HC Union Washer	4	
6	Drip Leg Heater with Clamps (25W, 115VAC)	1	HTH-111-115	11	Steel Union Bottom (3/4")	1	AH-1461-2
6	Drip Leg Heater with Clamps (25W, 230VAC)	1	HTH-111-230	11	Steel Union Bottom (1")	1	AH-1462-2
6	Drip Leg Heater with Clamps (25W, 24VDC)	1	HTH-111-024	12	Lead Gasket, Union (1.8" [45.72mm] OD x 1.35" [34.29mm] ID)	1	GAH-LED-1010
				13	Steel Union Top (3/4")	1	AH-1461-1
				14	HC Union Nut	2	



Date: 2022-04-19-v1
 EXPLODED VIEW AND BOM
 Dwg. No. VRH-1091-000

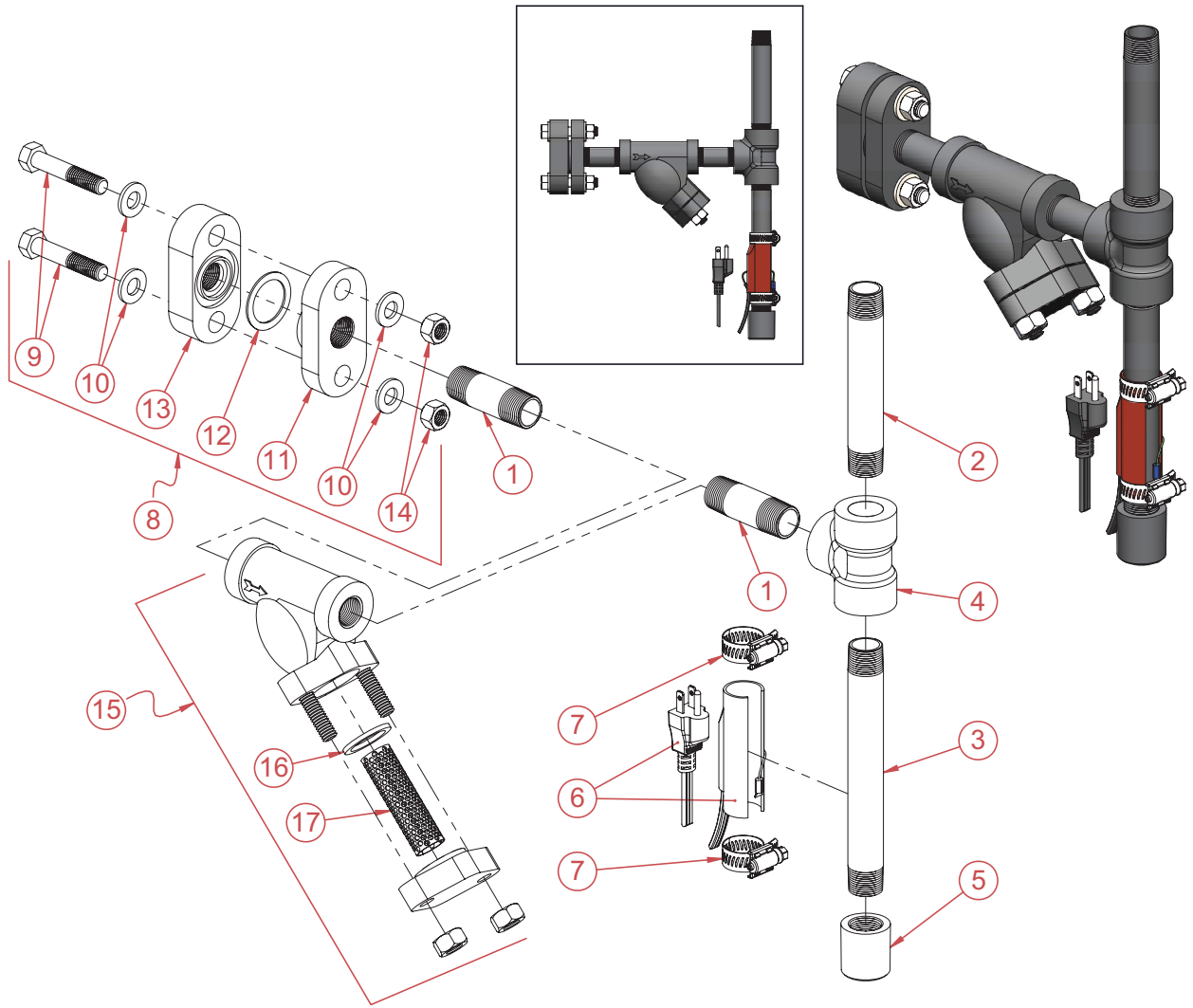

Item No.	Description	Quantity	Part No.	Item No.	Description	Quantity	Part No.
1	3/4" NPT 3" Seamless Carbon Steel Pipe Nipple (Schedule 80, ASTM A 106 Grade B)	2		7	Heater Clamp (two included with heater)	2	C-12
2	3/4" NPT 6" Seamless Carbon Steel Pipe Nipple (Schedule 80, ASTM A 106 Grade B)	1		8	3/4" NPT Steel Union	1	AH-1461
3	3/4" NPT 8" Seamless Carbon Steel Pipe Nipple (Schedule 80, ASTM A 106 Grade B)	1		8	3/4" to 1" NPT Steel Union	1	
4	3/4" NPT Seamless Carbon Steel Pipe Tee (Schedule 80, ASTM A 106 Grade B)	1		9	HC Union Bolt	2	
5	3/4" NPT Seamless Carbon Steel Pipe End Cap (Schedule 80, ASTM A 106 Grade B)	1		10	HC Union Washer	4	
6	Drip Leg Heater with Clamps (25W, 115VAC)	1	HTH-111-115	11	Steel Union Bottom (3/4")	1	AH-1461-2
6	Drip Leg Heater with Clamps (25W, 230VAC)	1	HTH-111-230	11	Steel Union Bottom (1")	1	AH-1462-2
6	Drip Leg Heater with Clamps (25W, 24VDC)	1	HTH-111-024	12	Lead Gasket, Union (1.8" [45.72mm] OD x 1.35" [34.29mm] ID)	1	GAH-LED-1010
				13	Steel Union Top (3/4")	1	AH-1461-1
				14	HC Union Nut	2	
				15	3/4" NPT Y-Strainer	1	RH-6786
				16	Y-Strainer Lead Gasket	1	RH-6787
				17	Monel Y-Strainer Screen	1	RH-2157



Date: 2022-04-19-v1
 EXPLODED VIEW AND BOM
 Dwg. No. VRH-1191-000

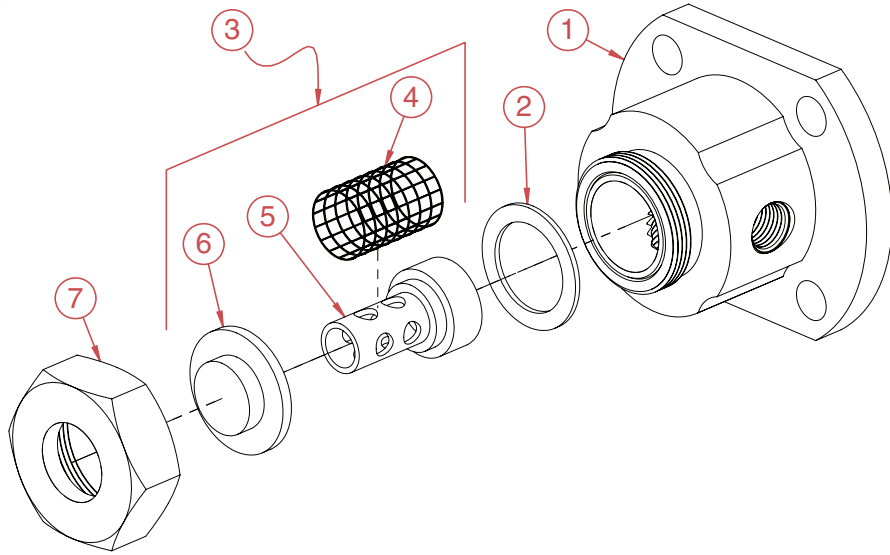
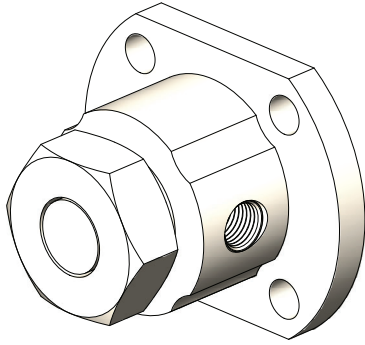

Item No.	Description	Quantity	Part No.
1	Inlet Assembly	1	VRH-1841-000
2	^{PM} Lead Gasket, Inlet	1	GAH-LED-124
3	Filter Assembly	1	VRH-187-000
4	^{PM} Filter Screen	1	VRH-133-000
5	Filter Holder	1	VRH-547-000
6	Filter Plug	1	VRH-230-000
7	Filter Cap	1	VRH-229-000
^{PM}	Part & Maintenance Kit	1	Refer to table below

PM components included with other parts in the following PM Kits:

Vacuum Regulator
 VRH-2000-CL2
 VRH-8000-CL2
 VRH-10000-CL2

PM Kit No.
 KTH-2000-VRW
 KTH-8000-VRW
 KTH-10000-VRW



Date: 2018-01-10-v1
 EXPLODED VIEW & BOM
 Dwg. No. VRH-5968-000

Inlet Adapter
Assembly
VRH-5978-000

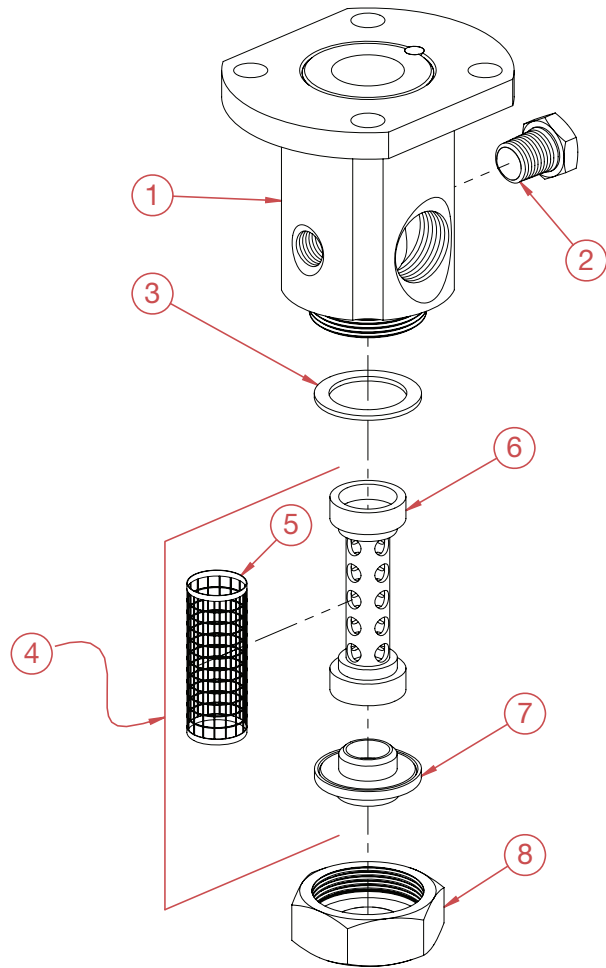
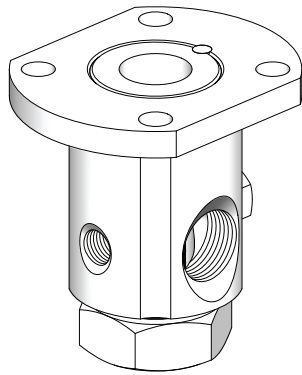

Item No.	Description	Quantity	Part No.
1	Inlet Assembly	1	VRH-1842-000
2	1/4" NPT Plug	1	PLH-105-004
3	^{PM} Lead Gasket, Inlet	1	GAH-LED-124
4	Filter Assembly	1	VRH-188-000
5	^{PM} Filter Screen	1	VRH-134-000
6	Filter Holder	1	VRH-548-000
7	Filter Plug	1	VRH-230-000
8	Filter Cap	1	VRH-229-000
^{PM}	Part & Maintenance Kit	1	Refer to table below

PM components included with other parts in the following PM Kits:

Vacuum Regulator	PM Kit No.
VRH-2000-CL2	KTH-2000-VRW
VRH-8000-CL2	KTH-8000-VRW
VRH-10000-CL2	KTH-10000-VRW
WR-10000-CL2	KTH-10000-WR



Date: 2019-04-17-v1
EXPLODED VIEW & BOM
Dwg. No. VRH-5978-000

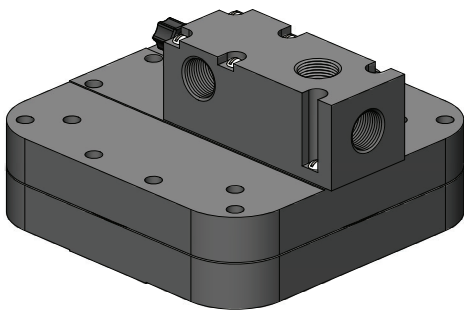

ALTERNATE VIEW -
OUTLET BLOCK
VERSIONS

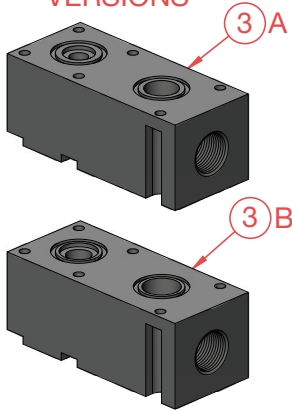

ORTHOGRAPHIC VIEWS

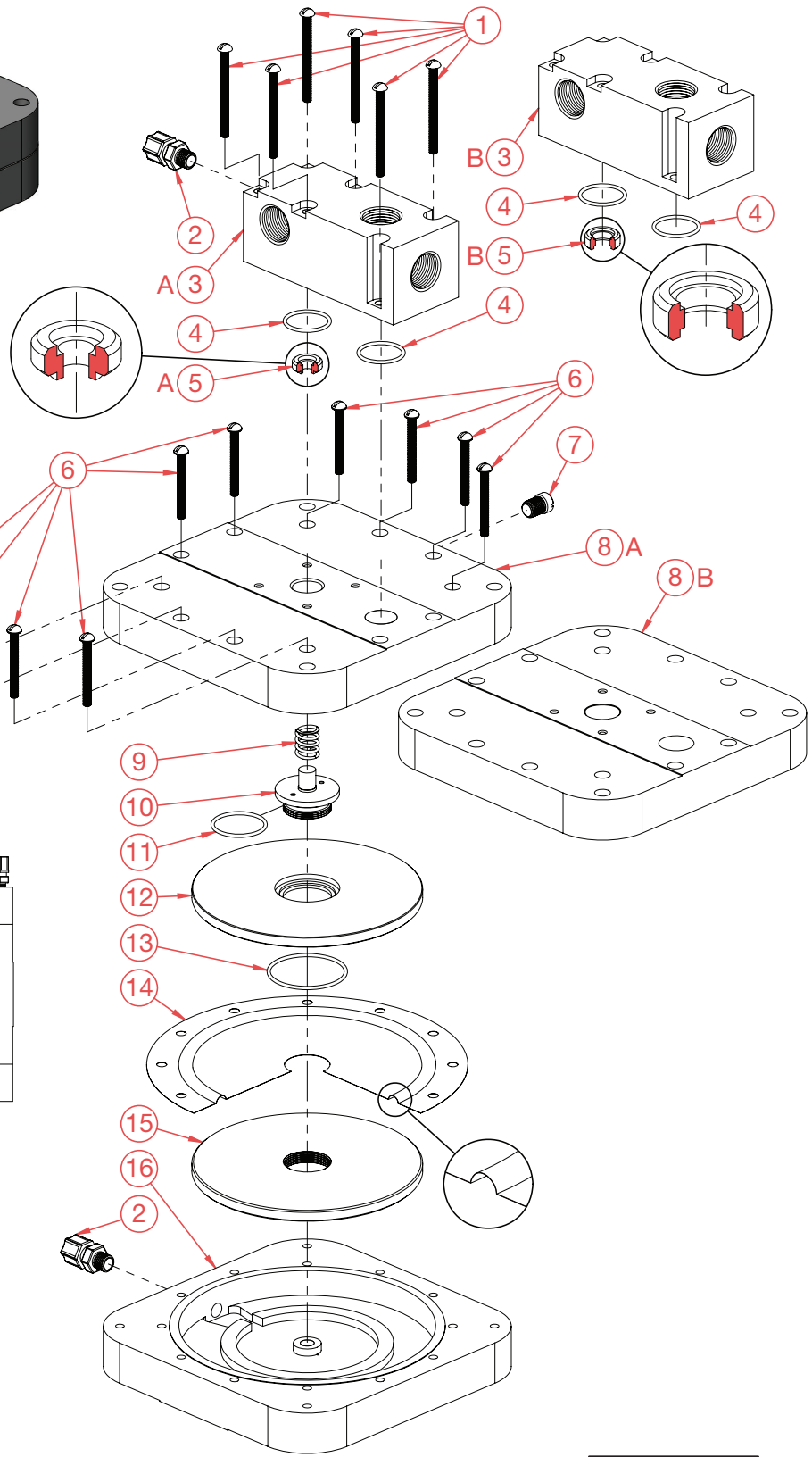
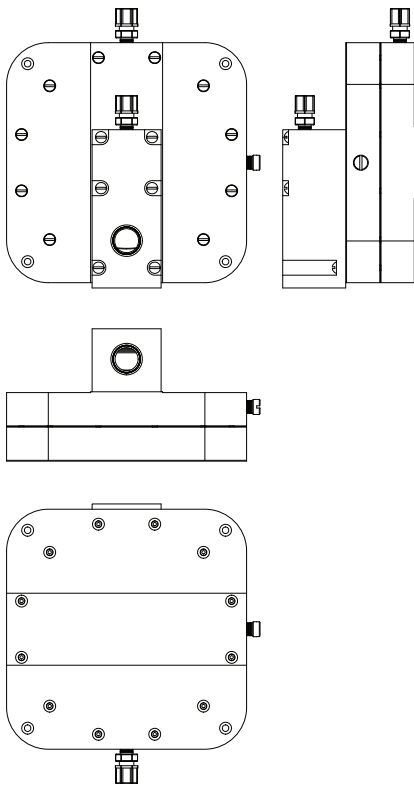

XXXX = 2000
6000

Item No.	Description	Quantity	Part No.
1	¼-20 x 3" RHMS (Monel)	6	BTH-STA-279
2	PM1, PM2 ¼" NPT ¾" Tube Tubing Connector	2	BKF-64
3A	Outlet Block (for DPH-2000-CL2)	1	DPH-2349-000
3B	Outlet Block (for DPH-6000-CL2)	1	DPH-2349-6000
4	PM1, PM2 O-Ring	2	OH-VIT-125
5A	PM1 Seat (for DPH-2000-CL2)	1	DPH-139-000
5B	PM2 Seat (for DPH-6000-CL2)	1	DPH-1139-6000
6	¼-20 x 2¼" RHMS (Monel)	10	BTH-STA-129
7	¼" NPT Plug	1	PLH-108-250
8A	Back Body (for DPH-2000-CL2)	1	DPH-1336-000
8B	Back Body (for DPH-6000-CL2)	1	DPH-1336-6000
9	Spring	1	SPH-109-000-HC
10	Diaphragm Bolt	1	DPH-334-000
11	PM1, PM2 O-Ring	1	OH-VIT-128
12	Diaphragm Back Plate	1	DPH-332-000
13	PM1, PM2 O-Ring	1	OH-VIT-141
14	Set of Two Diaphragms	1	DIH-110-000
15	Diaphragm Front Plate	1	VRH-333-000
16	Front Body	1	DPH-12704-000
PM1	Part & Maintenance Kit	1	KTH-2000-DPW
PM2	Part & Maintenance Kit	1	KTH-6000-DPW

XXXX = 2000 6000



Date: 2022-12-02-v1
BILL OF MATERIALS
Dwg. No. DPH-XXXX-CL2, BOM

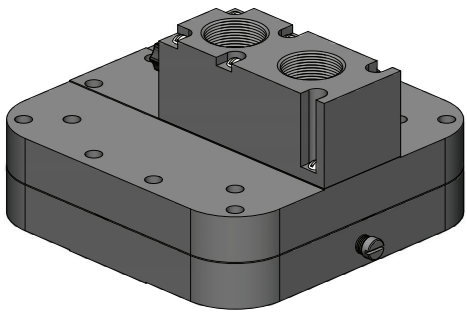

ALTERNATE VIEW -
OUTLET BLOCK

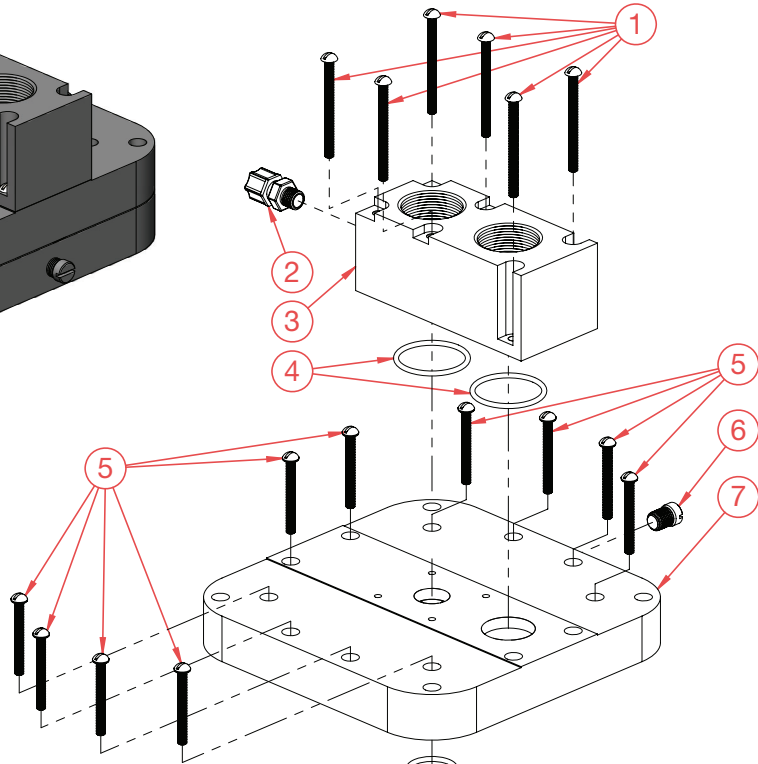
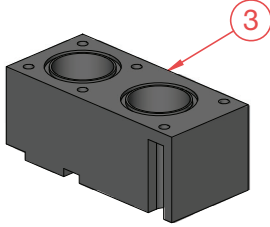

ORTHOGRAPHIC VIEWS

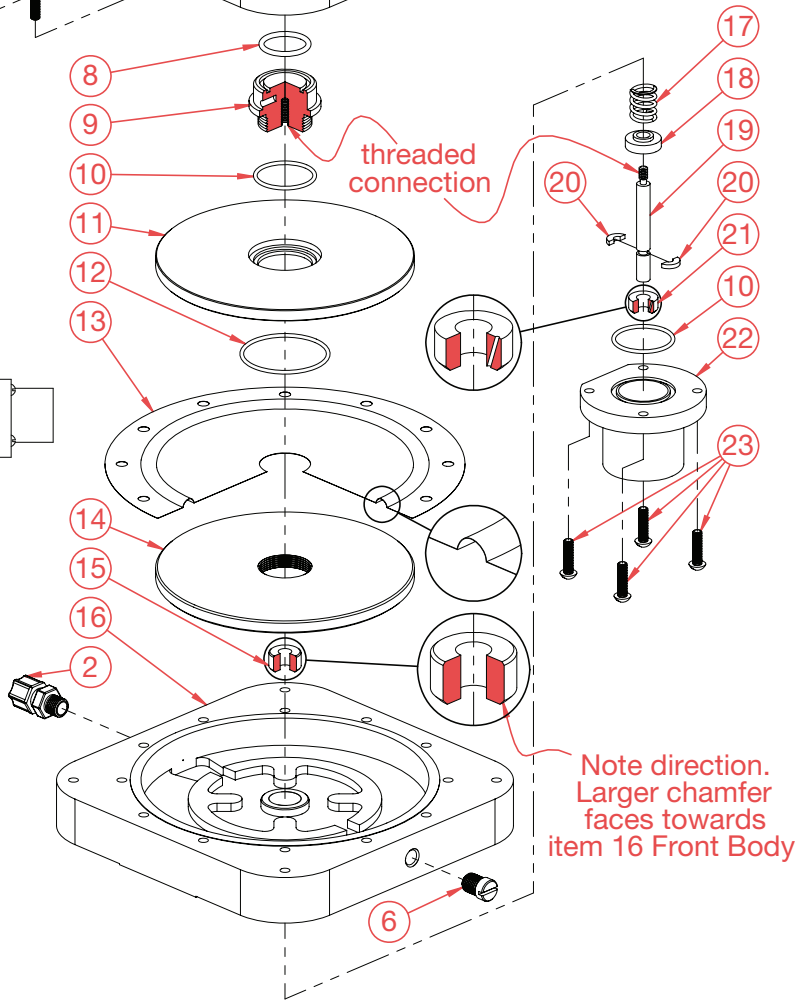
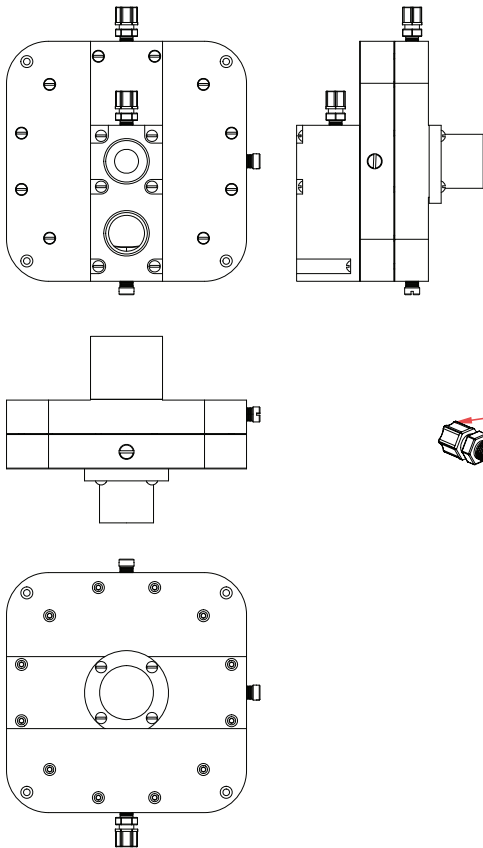

Item No.	Description	Quantity	Part No.
1	¼-20 x 3" RHMS (Monel)	6	BTH-STA-279
2	^{PM} ¼" NPT ¾" Tube Tubing Connector	2	BKF-64
3	Outlet Block	1	DPH-555-002
4	^{PM} O-Ring	2	OH-VIT-225
5	¼-20 x 2¼" RHMS (Monel)	10	BTH-STA-129
6	¼" NPT Plug	2	PLH-108-250
7	Back Body	1	DPH-548-000
8	^{PM} O-Ring	1	OH-VIT-217
9	Diaphragm Bolt	1	DPH-550-000
10	^{PM} O-Ring	2	OH-VIT-128
11	Diaphragm Back Plate	1	DPH-332-000
12	^{PM} O-Ring	1	OH-VIT-141
13	Set of Two Diaphragms	1	DIH-110-000
14	Diaphragm Front Plate	1	VRH-333-000
15	^{PM} Pin Guide	1	DPH-551-000
16	Front Body	1	DPH-549-000
17	Spring	1	SPH-109-000-HC
18	Spring Retainer	1	DPH-552-000
19	Guide Pin	1	DPH-184-000
20	Split Ring (set of 2)	1	DPH-185-000
21	^{PM} Guide	1	DPH-553-000
22	Guide Cap	1	DPH-554-000
23	¼-20 x 1" RHMS (Monel)	4	BTH-STA-126
^{PM}	Part & Maintenance Kit	1	KTH-10000-DPW



Date: 2022-12-02-v1
 BILL OF MATERIALS
 Dwg. No. DPH-10000-CL2, BOM

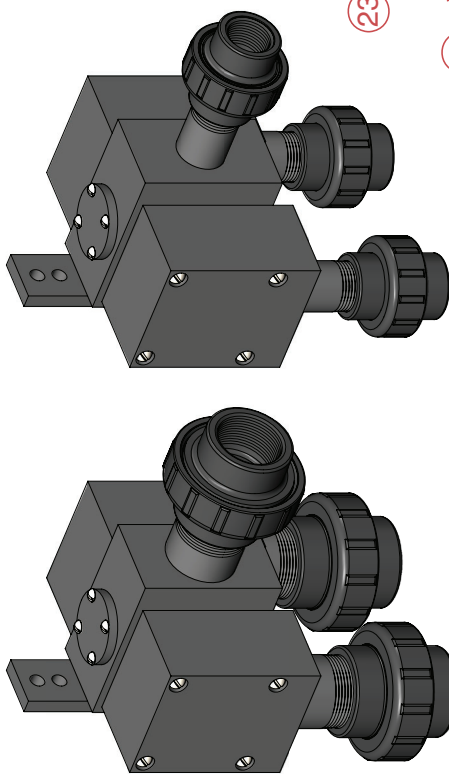

SOH-2000-CL2

SOH-4000-CL2

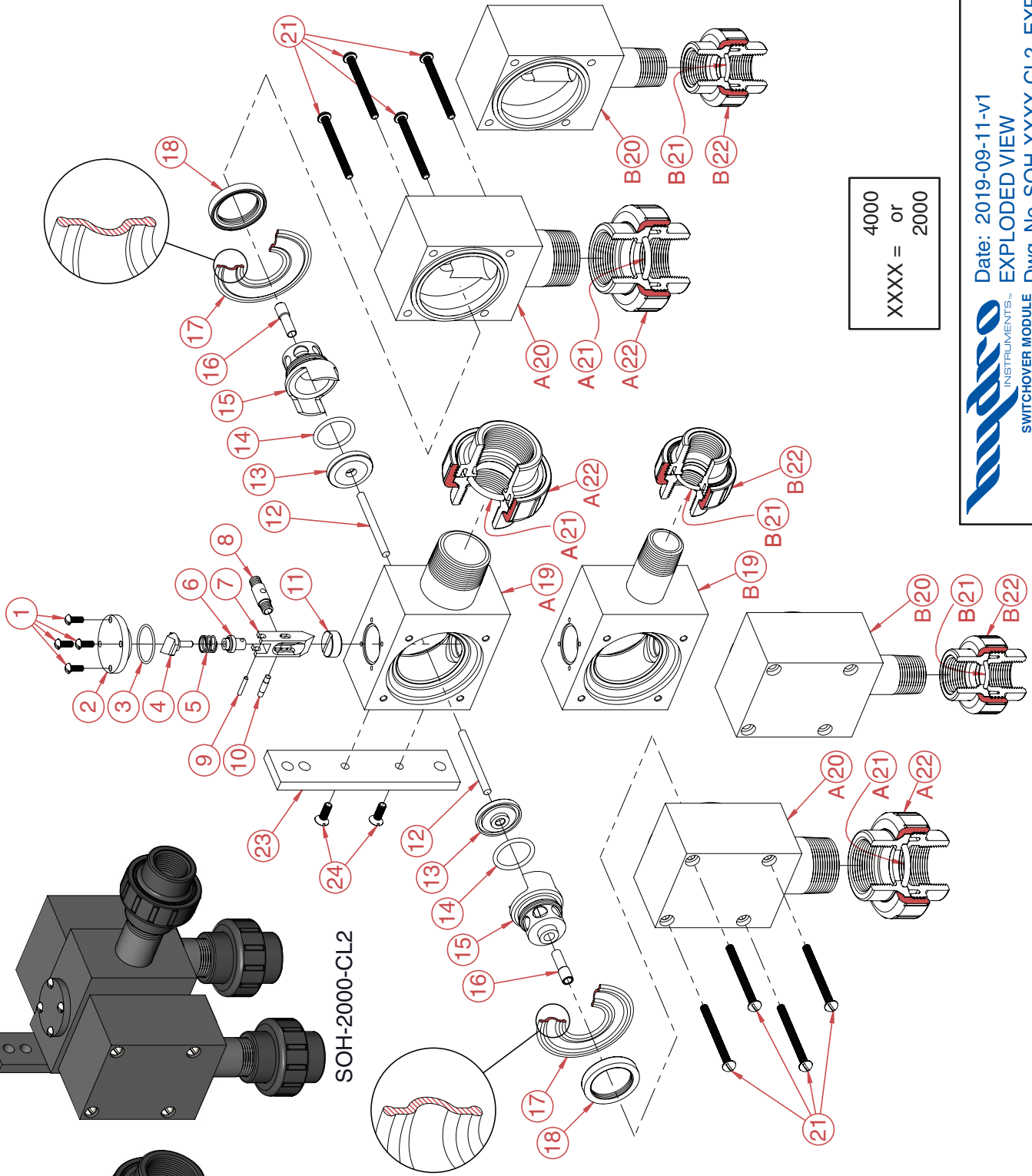

4000
XXXX = or
2000

Item No.	Description	Quantity	Part No.
1	Screw, 10-24, 1/2" Fill HD	4	BTH-STA-138
2	Toggle Cap	1	SOH-419-000
3	PM4, PM2 O-Ring	1	OH-VIT-025
4	Spring Pivot Assembly (with pin)	1	SOH-277-500
5	Spring	1	YM-103-HC-1
6	Pin Pivot	1	SOH-513-500
7	Toggle Spindle	1	SOH-855-000
8	Valve Stud	1	SOH-141-000
9	Pin	1	SOH-176-500
10	Toggle Pin	1	SOH-168-500
11	Toggle Plate	1	SOH-854-000
12	Guide Pin	2	SOH-169-000
13	Valve	2	SOH-184-000
14	PM4, PM2 O-Ring	2	OH-VIT-217
15	Diaphragm Bolt	2	SOH-183-000
16	Guide Sleeve	2	SOH-170-000
17	PM4, PM2 Diaphragm	2	DIH-116-000
18	PM4, PM2 Diaphragm Nut	2	SOH-163-000
19 A	Center Body 1.5" (4,000 PPD)	1	SOH-139-015
19 B	Center Body 1" (2,000 PPD)	1	SOH-139-010
20 A	Body Flange 1.5" (4,000 PPD)	2	SOH-128-015
20 B	Body Flange 1" (2,000 PPD)	2	SOH-128-010
21	Screw, 1/4-20, 2 3/4" RH	8	BTH-STA-125
21 A	PM4 O-Ring (4,000 PPD)	3	OH-VIT-328
21 B	PM2 O-Ring (2,000 PPD)	3	OH-VIT-215
22 A	1 1/2" PVC Union (4,000 PPD)	3	U-4298
22 B	1" PVC Union (2,000 PPD)	3	U-4475
23	Mounting Bracket	1	SOH-396-000
24	Mounting Plate Screws, 1/4-20, 3/4" FH	2	BTH-STA-555
PM4	Part & Maintenance Kit (4000 PPD)	1	KTH-4000-SOM
PM2	Part & Maintenance Kit (2000 PPD)	1	KTH-2000-SOM

XXXX = 4000
or
2000

FIGURE 5 – EXAMPLE FLOW METER: RMH-1000-CL2

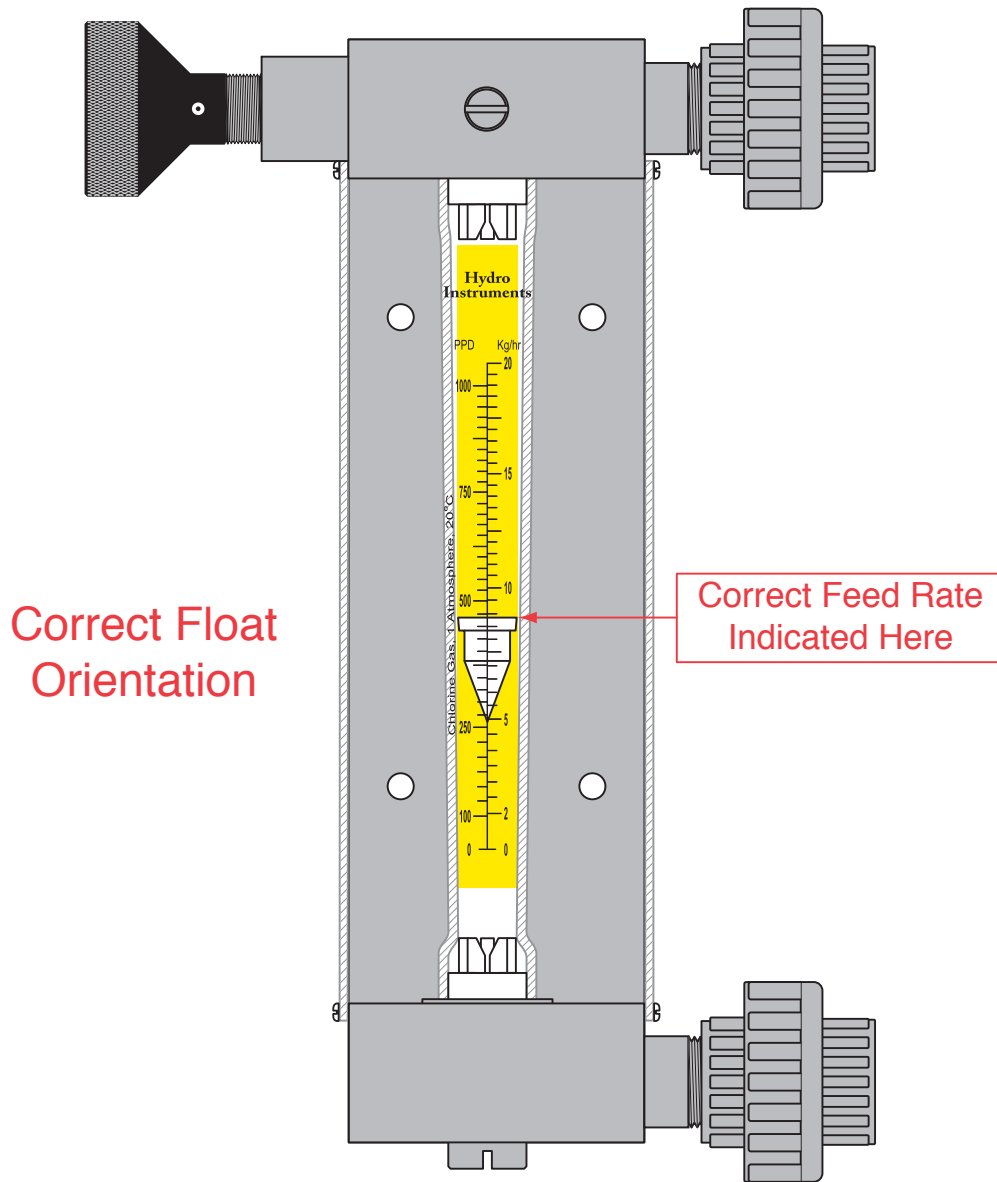
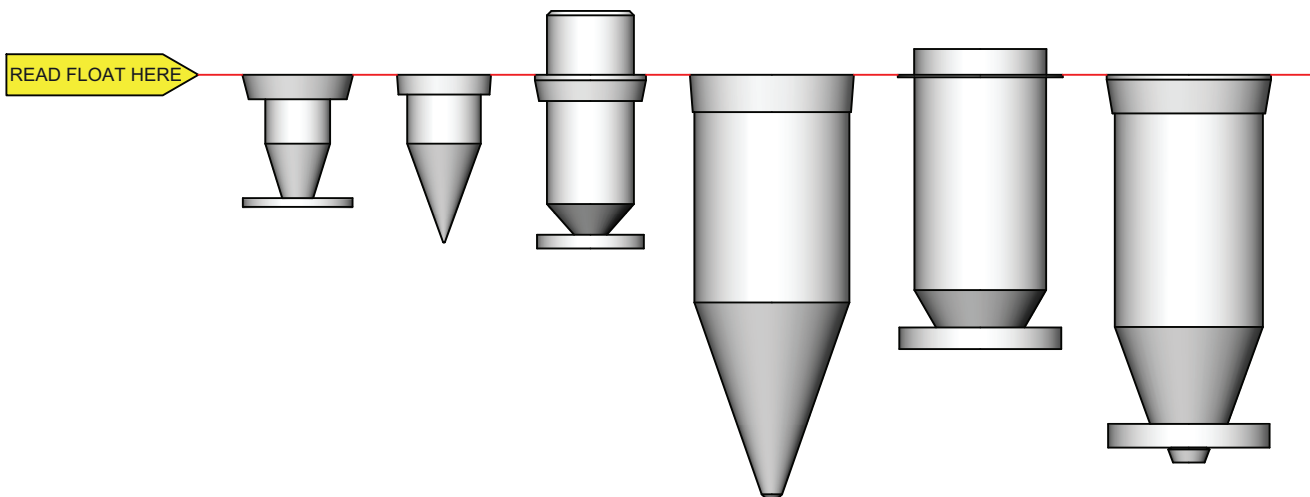
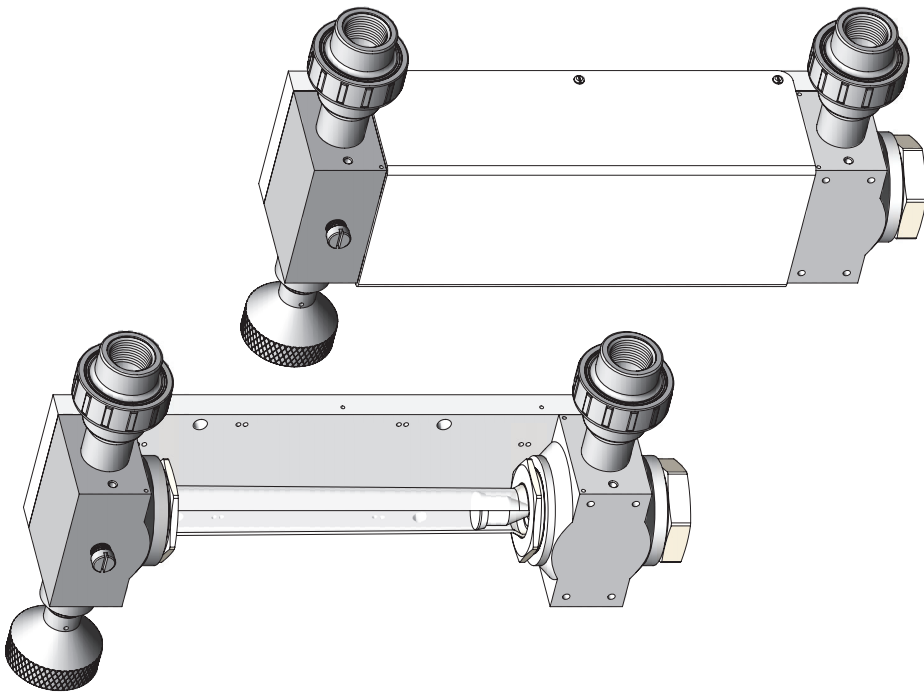
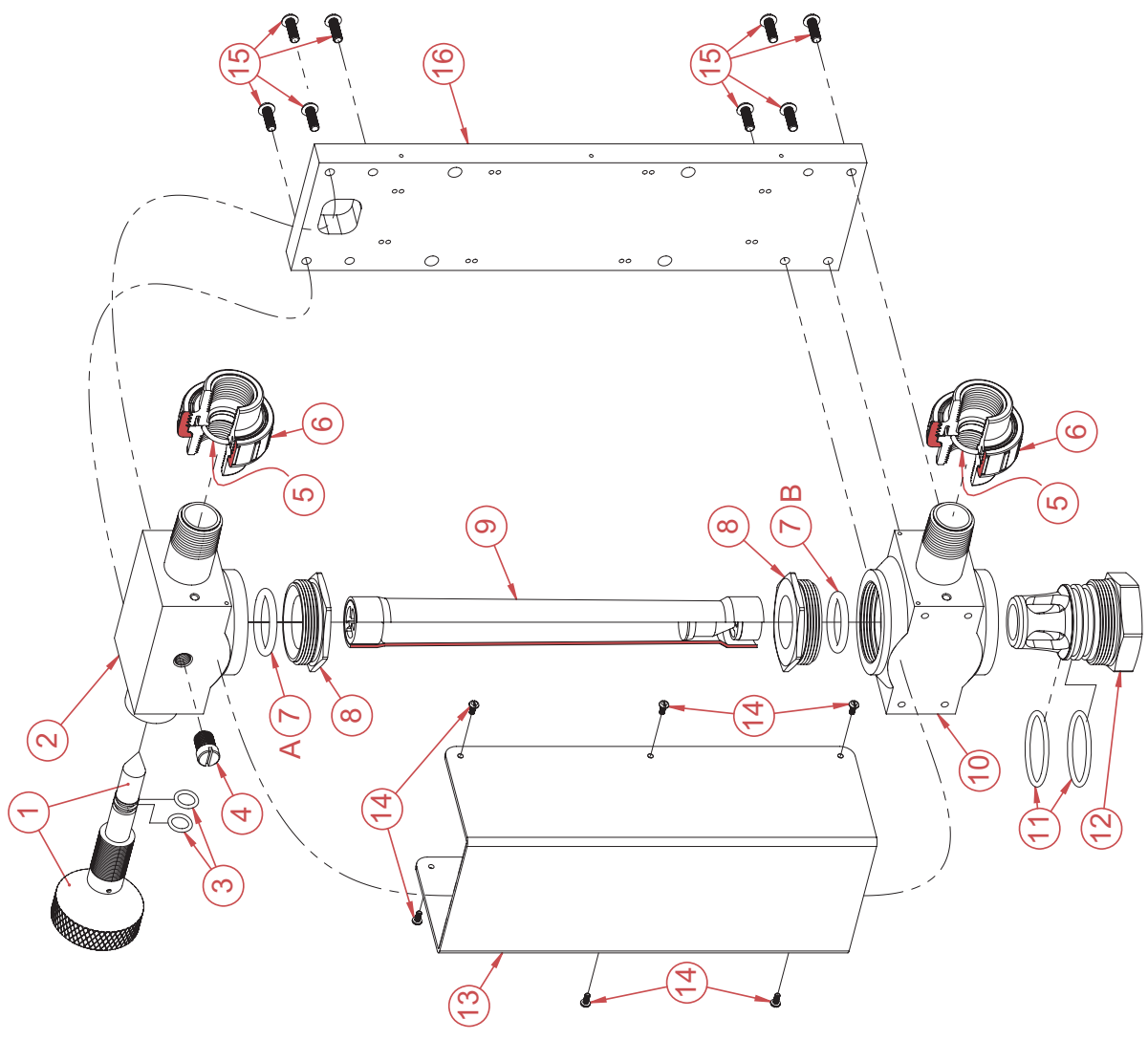

FIGURE 6 – READING EDGE FOR VARIOUS FLOAT SHAPES





0125
0250
0500
0800
1000
1500
2000
3000
XXXX =



 Date: 2022-04-19-v1
 INSTRUMENTS™
 EXPLODED VIEW
 12" REMOTE METER, Dwg. No. RMH-XXXX-CL2, EXP

Item No.	Description	Quantity	Part No.	Item No.	Description	Quantity	Part No.
1	Rate Valve Stem with Knob & Pin	1	RVH-411-000	13	Meter Shield	1	MSU-12T-THN
2	Top Meter Block	1	MBH-UB2-300	14	Meter Shield Screws	6	#6-32 x 5/16"
3	^{PM} O-Ring	2	OH-VIT-112	15	Meter Block Screws	8	BTH-STA-189
4	1/4" NPT Plug	1	PLH-108-250	16	Meter Base	1	MBU-12T-THN
5	^{PM} O-Ring (for 1" PVC Union)	2	OH-VIT-215				
6	1" PVC Union	2	U-4475				
7A	^{PM} O-Ring	1	OH-VIT-324				
7B	^{PM} O-Ring	1	OH-VIT-322				
8	Meter Tube Hex Nut	2	MBH-THN-300				
9A	Meter Tube (125 PPD / 2.5 Kg/h)	1	MT-025				
9B	Meter Tube (250 PPD / 5.0 Kg/h)	1	MT-05				
9C	Meter Tube (500 PPD / 10 Kg/h)	1	MT-10				
9D	Meter Tube (800 PPD / 15 Kg/h)	1	MT-15				
9E	Meter Tube (1,000 PPD / 20 Kg/h)	1	MT-20				
9F	Meter Tube (1,500 PPD / 30 Kg/h)	1	MT-30				
9G	Meter Tube (2,000 PPD / 40 Kg/h)	1	MT-40				
9H	Meter Tube (3,000 PPD / 60 Kg/h)	1	MT-60				
10	Bottom Meter Block	1	MBH-LB3-300				
11	^{PM} O-Ring	2	OH-VIT-224				
12	Meter Inlet Plug	1	MIH-300-000				
					PM Parts & Maintenance Kit	1	KTH-3000-RMS

0125	
0250	
0500	
XXXX =	0800
	1000
	1500
	2000
	3000

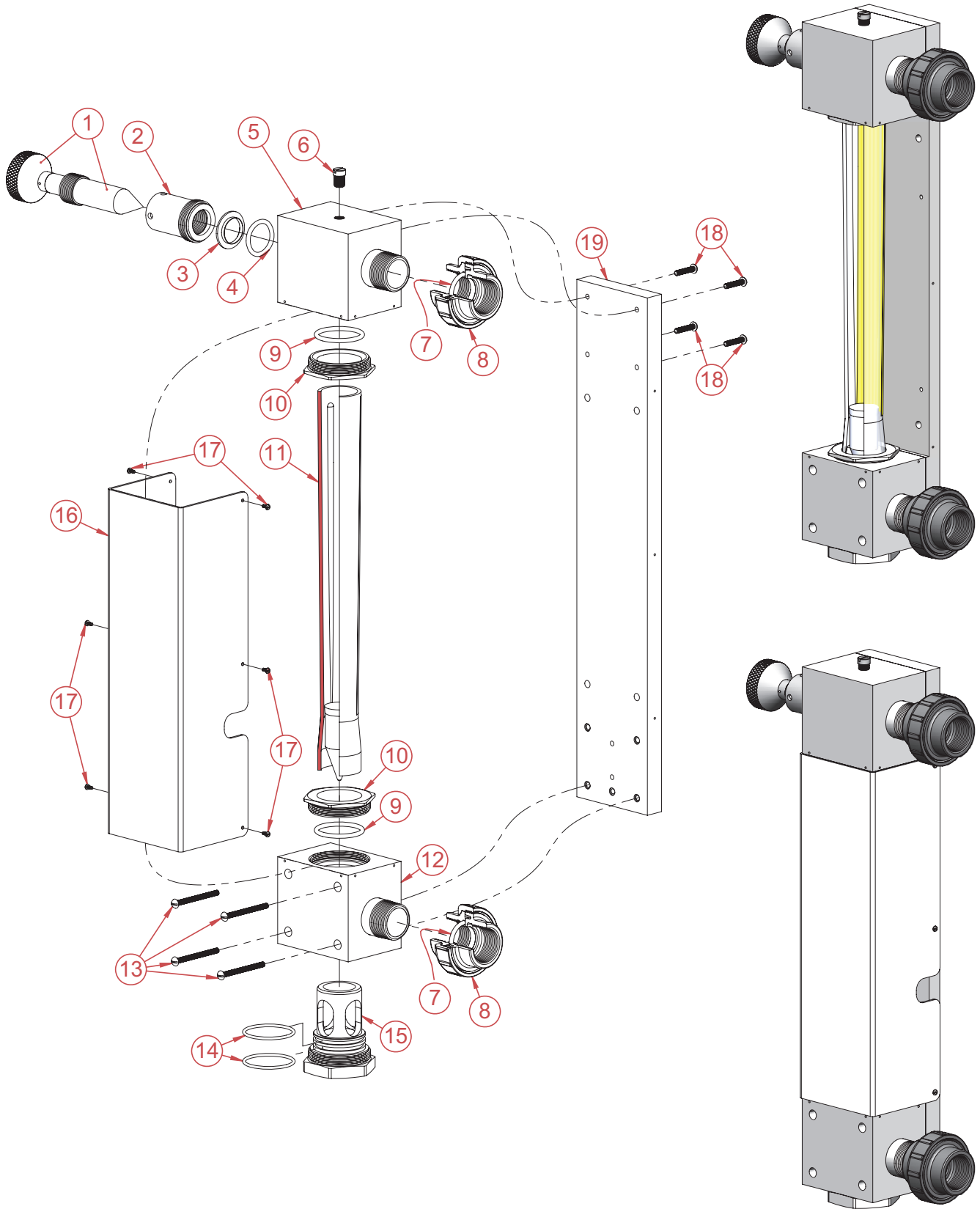

XXXX =	4000
	6000
	8000
	10000

hydro
INSTRUMENTS™
20" HIGH CAPACITY REMOTE METER
(4,000 - 10,000 PPD)

Date: 2022-12-02-v1
EXPLODED VIEW
Dwg. No. MPH-XXXXX-CL2, EXP

Item No.	Description	Quantity	Part No.
1	Rate Valve Stem & Knob	1	RVH-412-10000
2	Valve Bonnet	1	MBH-VB-10000
3	^{PM} Shaft Seal	1	RVH-852-SEAL
4	^{PM} O-Ring (for Rate Valve)	1	OH-VIT-324
5	Top Meter Block (for 1.5" Union)	1	MBH-UB2-10000
6	¼" NPT Plug	1	PLH-108-250
7	^{PM} O-Ring (for 1.5" Union)	2	OH-VIT-328
8	1.5" Union	2	U-4298
9	^{PM} O-Ring (for Meter Tube)	2	OH-VIT-330
10	Meter Tube Hex Nut	2	MBH-THN-10000
11	Meter Tube (4000 PPD / 80 kg/hr)	1	MTB-80KG-20
11	Meter Tube (6000 PPD / 120 kg/hr)	1	MTB-120KG-20
11	Meter Tube (8000 PPD / 160 kg/hr)	1	MTB-160KG-20
11	Meter Tube (10,000 PPD / 200 kg/hr)	1	MTB-200KG-20
12	Bottom Meter Block (for 1.5" Union)	1	MBH-LB3-10000
13	¼-20 x 3" Bolt	4	BTH-STA-279
14	^{PM} O-Ring	2	OH-VIT-229
15	Meter Inlet Plug	1	MIH-500-000
16	Meter Shield	1	MSU-20T-THN
17	Shield Screws	6	#6-32 x 5/16"
18	¼-20 x 1¼" Bolt	4	BTH-STA-130
19	Meter Base	1	MBH-MB-10000
^{PM}	Part & Maintenance Kit	1	KTH-10000-MPS

XXXX =	4000
	6000
	8000
	10000



Date: 2022-12-02-v1
EXPLODED VIEW
 20" HIGH CAPACITY REMOTE METER (4,000 - 10,000 PPD)
 Dwg. No. MPH-XXXXX-CL2, BOM

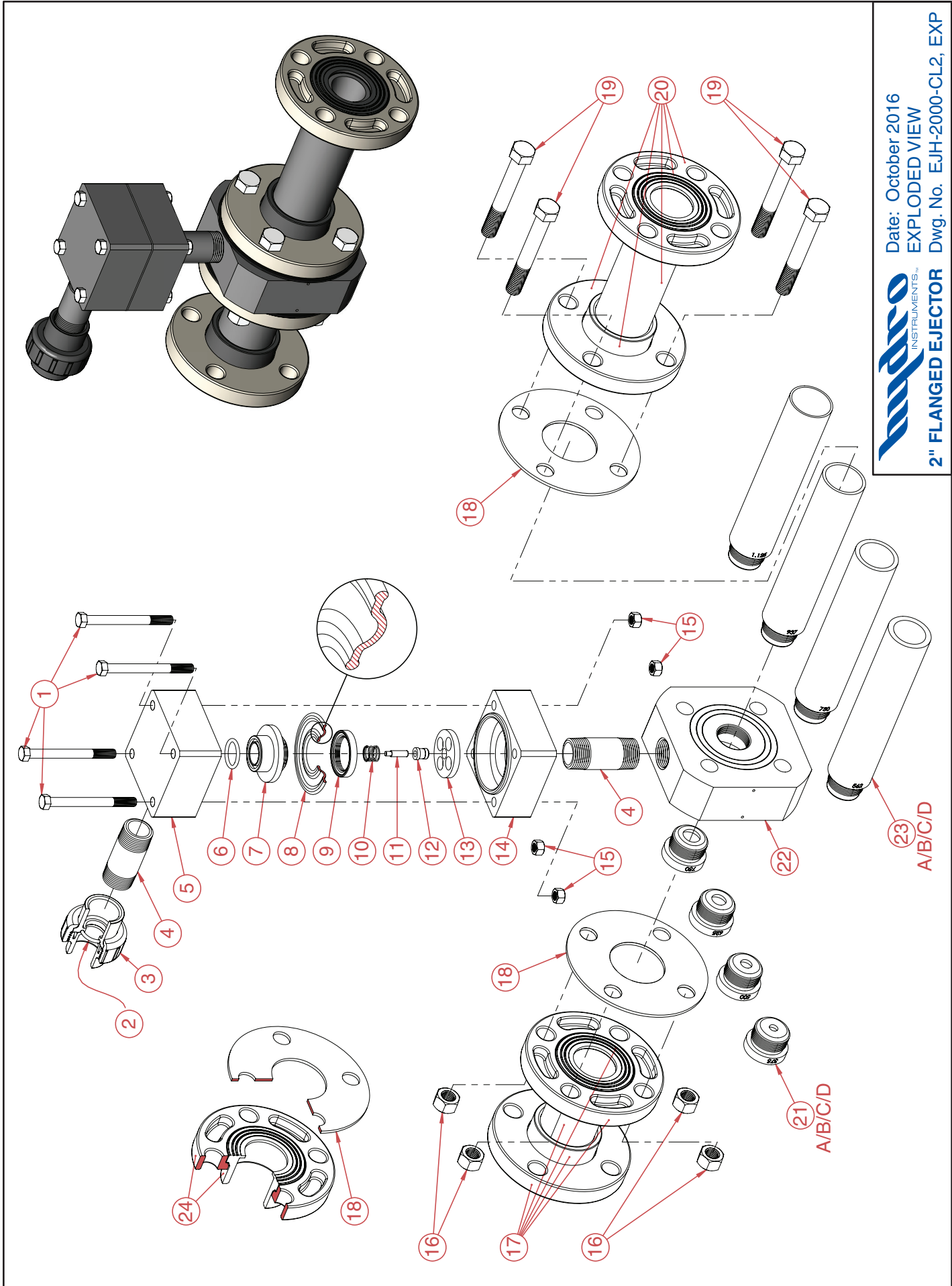



 Date: October 2016
 EXPLODED VIEW
2" FLANGED EJECTOR Dwg. No. EJH-2000-CL2, EXP

Item No.	Description	Quantity	Part No.
1	3/8"-16 x 4" Long Hex Bolt	4	BTH-STA-158
2	PM O-Ring	1	OH-VIT-215
3	1" Union Assembly	1	U-4475
4	1" PVC Nipple x 3"	2	RH-306-000
5	Ejector Check Valve Top Body	1	EJH-168-000
6	PM O-Ring	1	OH-CEM-214
7	PM Diaphragm Bolt (2" Ejector)	1	EJH-162-000
8	PM Diaphragm	1	DIH-116-000
9	PM Diaphragm Nut (2" Ejector)	1	EJH-163-000
10	Spring (2" Ejector)	1	SPH-110-000
11	Guide Pin (2" Ejector)	1	EJH-140-000
12	Pin Guide (2" Ejector)	1	EJH-151-000
13	Spring Retainer (2" Ejector)	1	EJH-164-000
14	Ejector Check Valve Bottom Body	1	EJH-167-000
15	Nut, 3/8"-16	4	NTH-STA-146
16	Nut, 5/8"-11 Hex	4	NTH-STA-230
17	Nozzle Housing Assembly	1	RH-891-000
18	PM Gasket (2" Ejector) (two installed, two loose)	4	RH-308-000
19	Bolt, 5/8"-11 x 4 1/2" Long	4	BTH-STA-156
20	Throat Housing Assembly	1	RH-890-000
21 A	Nozzle (0.375" Orifice)	1	EJH-165-375
21 B	Nozzle (0.500" Orifice)	1	EJH-165-500
21 C	Nozzle (0.625" Orifice)	1	EJH-165-625
21 D	Nozzle (0.750" Orifice)	1	EJH-165-750
22	Ejector Body (2" Ejector)	1	EJH-169-000
23 A	Throat (0.562" Orifice)	1	EJH-166-562
23 B	Throat (0.750" Orifice)	1	EJH-166-750
23 C	Throat (0.937" Orifice)	1	EJH-166-937
23 D	Throat (1.125" Orifice)	1	EJH-166-1125
24	Flange (2" Socket) (four installed, two loose)	6	RH-1221
PM	Part & Maintenance Kit	1	KTH-2000-EJS
*	Flanges are 2 inch, four bolt, 150 lb., S (Van Stone style) in Schedule 80 PVC.		

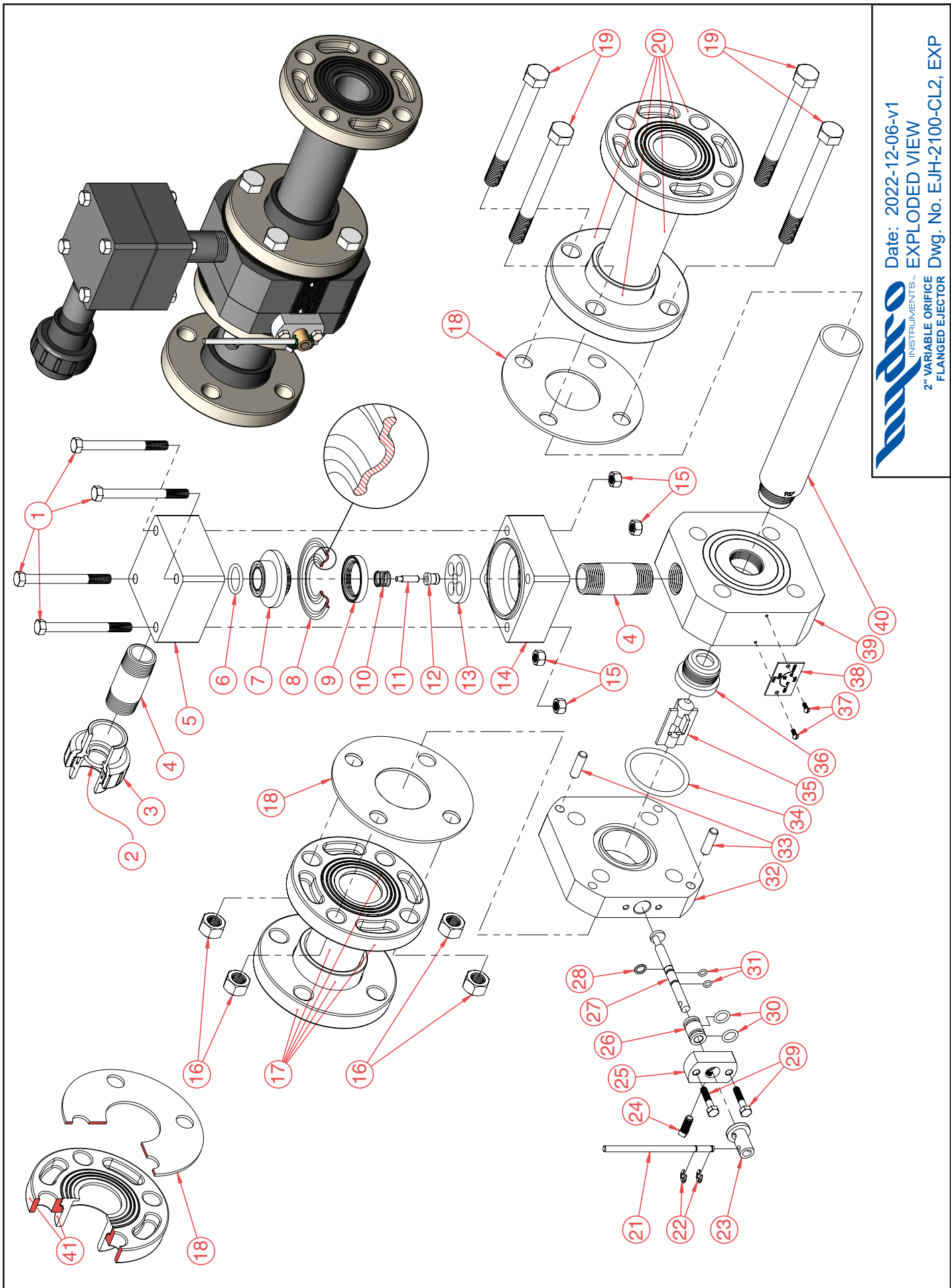

Date: October 2016
 BILL OF MATERIALS
 Dwg. No. EJH-2000-CL2, BOM



Item No.	Description	Quantity	Part No.	Item No.	Description	Quantity	Part No.
1	3/8" -16 x 4" Long Hex Bolt	4	BTH-STA-158	23	Sleeve	1	EJH-1234-000
2	^{PM} O-Ring	1	OH-VIT-215	24	Square Head Set Screw, 5/16"-18 x 3/4"	1	BTH-STA-237
3	1" Union Assembly	1	U-4475	25	Collar	1	EJH-1233-000
4	1" PVC Nipple x 3"	2	RH-306-000	26	Shaft Guide	1	EJH-1917-000
5	Ejector Check Valve Top Body	1	EJH-168-000	27	Shaft Cam Assembly	1	EJH-1502-000
6	^{PM} O-Ring	1	OH-CEM-214	28	Shaft Cam Ring	1	EJH-1235-000
7	^{PM} Diaphragm Bolt (2" Ejector)	1	EJH-162-000	29	Hex Head Cap Screw, 1/4-20 x 1.25" Long	2	BTH-STA-329
8	^{PM} Diaphragm	1	DIH-116-000	30	^{PM} O-Ring	2	OH-VIT-112
9	^{PM} Diaphragm Nut (2" Ejector)	1	EJH-163-000	31	^{PM} O-Ring	2	OH-VIT-010
10	Spring (2" Ejector)	1	SPH-110-000	32	Variable Orifice Body (2" Ejector)	1	EJH-1916-000
11	Guide Pin (2" Ejector)	1	EJH-140-000	33	Dowel Pin	2	EJH-452-000
12	Pin Guide (2" Ejector)	1	EJH-151-000	34	^{PM} O-Ring	1	OH-VIT-331
13	Spring Retainer (2" Ejector)	1	EJH-164-000	35	Ejector Plug Assembly (2" Ejector)	1	EJH-1501-000
14	Ejector Check Valve Bottom Body	1	EJH-167-000	36	Variable Nozzle (2" Ejector)	1	EJH-1915-000
15	Nut, 3/8"-16	4	NTH-STA-146	37	Middle Body Plate Screw	2	EJH-784-000
16	Nut, 5/8"-11 Hex	4	NTH-STA-230	38	Middle Body Plate (2" Ejector)	1	EJH-112-000
17	Nozzle Housing Assembly	1	RH-891-000	39	Ejector Body (2" Ejector)	1	EJH-169-000
18	^{PM} Gasket (2" Ejector) (two installed, two loose)	4	RH-308-000	40	Throat (0.937" Orifice)	1	EJH-166-937
19	Bolt, 5/8"-11 x 6" Long	4	BTH-STA-241	41	Flange (2" Socket) (four installed, two loose)	6	RH-1221
20	Throat Housing Assembly	1	RH-890-000	^{PM}	Part & Maintenance Kit	1	KTH-2100-EJS
21	Handle	1	EJH-1236-000	*	Flanges are 2 inch, four bolt, 150 lb., S (Van Stone style) in Schedule 80 PVC.		
22	^{PM} E-Clip	2	RH-5373-000				

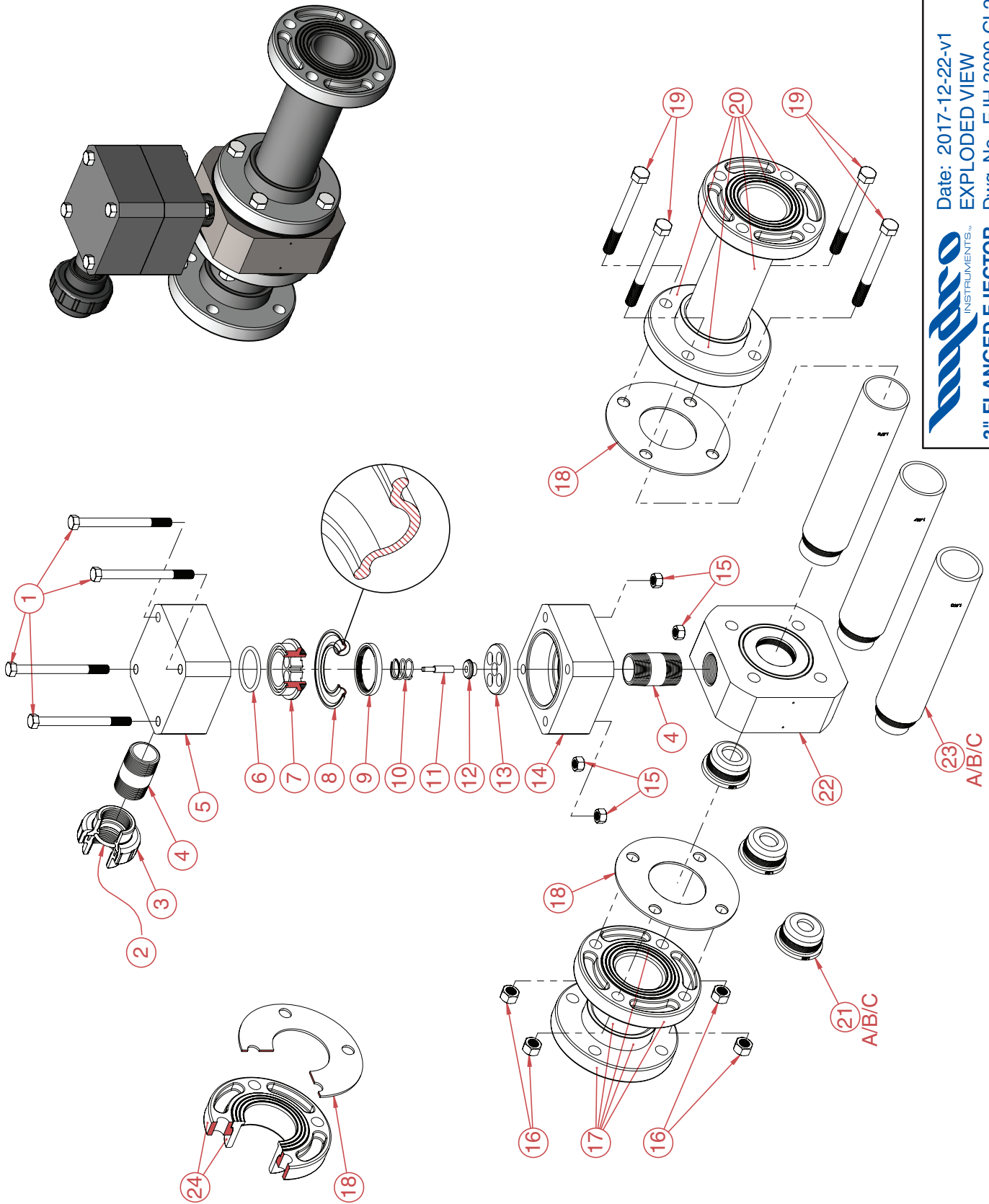

3" FLANGED EJECTOR Dwg. No. EJH-3000-CL2, EXP
 Date: 2017-12-22-v1
 EXPLODED VIEW

Item No.	Description	Quantity	Part No.
1	1/2"-13 x 6" Long Bolt	4	BTH-STA-191
2	PM O-Ring	1	OH-VIT-328
3	1.5" Union	1	U-4298
4	1 1/2" x 3" Nipple	2	RH-481-000
5	Ejector Check Valve Top Body	1	EJH-175-000
6	PM O-Ring	1	OH-CEM-331
7	PM Diaphragm Bolt	1	EJH-173-000
8	PM Diaphragm	1	DIH-117-000
9	PM Diaphragm Nut	1	EJH-178-000
10	Spring	1	SPH-115-000
11	Guide Pin	1	EJH-191-000
12	Pin Guide	1	EJH-190-000
13	Spring Retainer	1	EJH-172-000
14	Ejector Check Valve Bottom Body	1	EJH-174-000
15	Nut, 1/2"-13 Hex	4	NTH-STA-192
16	Nut, 5/8"-11 Hex	4	NTH-STA-230
17	Nozzle Housing Assembly *	1	RH-892-000
18	PM Flange Gasket (two installed, two loose)	4	RH-477-000
19	Bolt, 5/8"-11 x 6" Long	4	BTH-STA-241
20	Throat Housing Assembly *	1	RH-893-000
21 A	Nozzle (1.000" Orifice)	1	EJH-185-1000
21 B	Nozzle (1.125" Orifice)	1	EJH-185-1125
21 C	Nozzle (1.250" Orifice)	1	EJH-185-1250
22	Ejector Body (3" Ejector)	1	EJH-177-000
23 A	Throat (1.500" Orifice)	1	EJH-171-1500
23 B	Throat (1.687" Orifice)	1	EJH-171-1687
23 C	Throat (1.875" Orifice)	1	EJH-171-1875
24	Flange (3" Socket)* (four installed, two loose)	6	RH-1222
PM	Part & Maintenance Kit	1	KTH-3000-EJS
*	Flanges are 3 inch, four bolt, 150 lb., S (Van Stone style) in Schedule 80 PVC.		

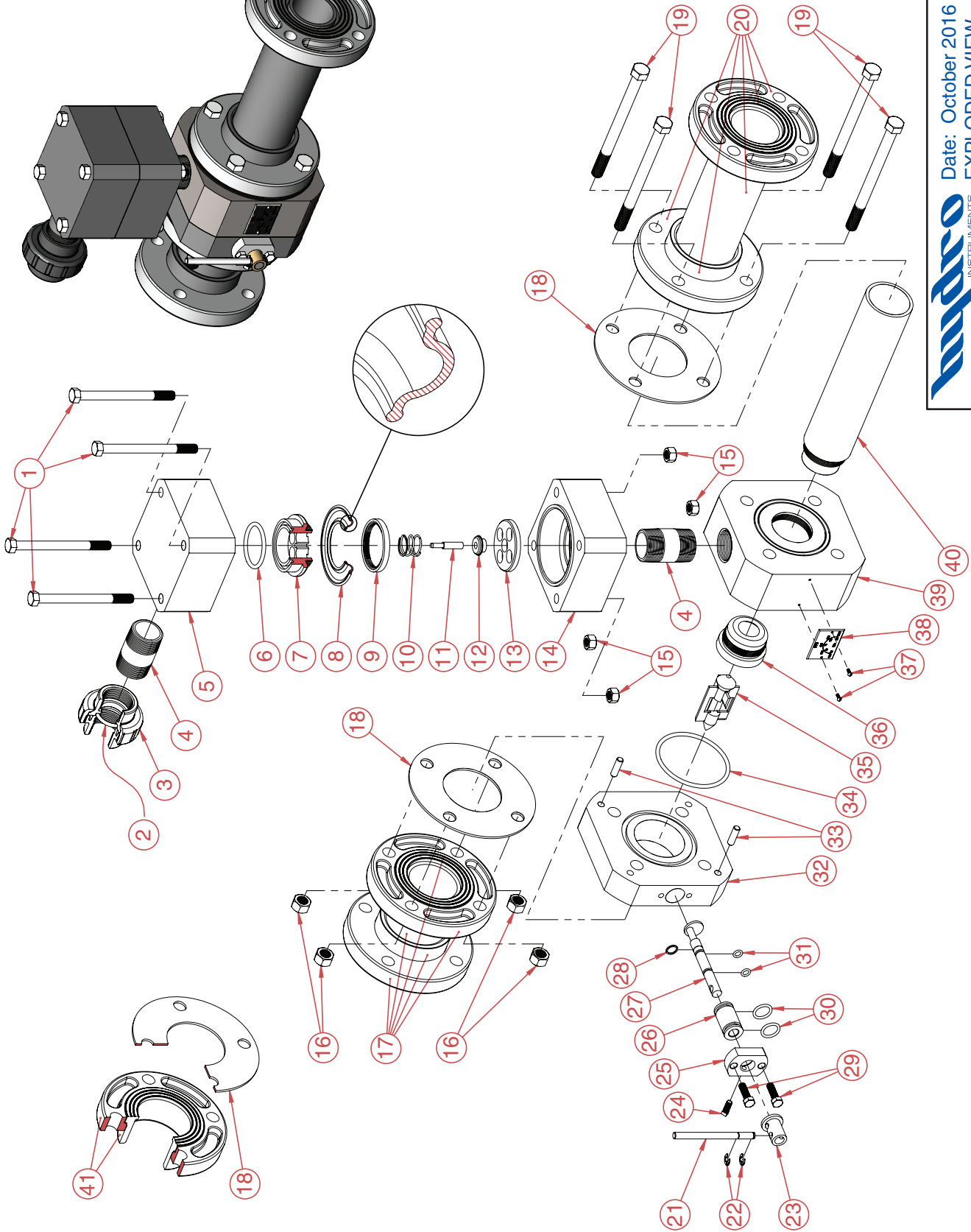
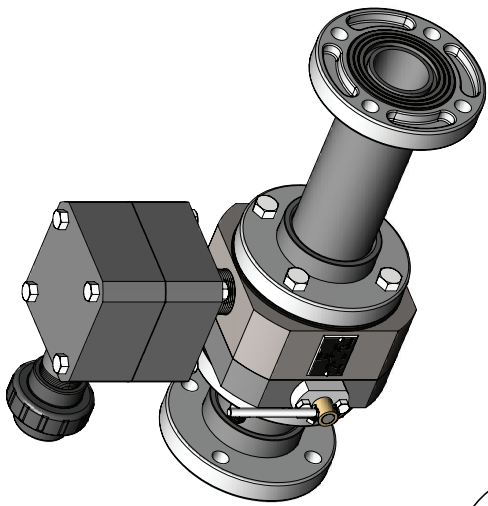

 Date: October 2016
 EXPLODED VIEW
 3" VARIABLE ORIFICE
 FLANGED EJECTOR Dwg. No.: E-JH-3100-CL2, EXP

Item No.	Description	Quantity	Part No.	Item No.	Description	Quantity	Part No.
1	1/2"-13 x 6" Long Bolt	4	BTH-STA-191	23	Sleeve	1	EJH-451-000
2	^{PM} O-Ring	1	OH-VIT-328	24	Square Head Set Screw, 5/16"-18 x 3/4"	1	BTH-STA-237
3	1.5" Union	1	U-4298	25	Collar	1	EJH-453-000
4	1 1/2" x 3" Nipple	2	RH-481-000	26	Shaft Guide	1	EJH-898-000
5	Ejector Check Valve Top Body	1	EJH-175-000	27	Shaft Cam Assembly	1	EJH-365-000
6	^{PM} O-Ring	1	OH-CEM-331	28	Shaft Cam Ring	1	EJH-455-000
7	^{PM} Diaphragm Bolt	1	EJH-173-000	29	Hex Head Cap Screw, 3/8"-16 x 1 1/4"	2	BTH-STA-152
8	^{PM} Diaphragm	1	DIH-117-000	30	^{PM} O-Ring	2	OH-VIT-212
9	^{PM} Diaphragm Nut	1	EJH-178-000	31	^{PM} O-Ring	2	OH-VIT-110
10	Spring	1	SPH-115-000	32	Variable Orifice Body	1	EJH-195-000
11	Guide Pin	1	EJH-191-000	33	Dowel Pin	2	EJH-452-000
12	Pin Guide	1	EJH-190-000	34	^{PM} O-Ring	1	OH-VIT-345
13	Spring Retainer	1	EJH-172-000	35	Ejector Plug Assembly	1	EJH-364-000
14	Ejector Check Valve Bottom Body	1	EJH-174-000	36	Variable Nozzle	1	EJH-194-000
15	Nut, 1/2"-13 Hex	4	NTH-STA-192	37	Middle Body Plate Screw	2	EJH-784-000
16	Nut, 5/8"-11 Hex	4	NTH-STA-230	38	Middle Body Plate	1	EJH-111-000
17	Nozzle Housing Assembly *	1	RH-892-000	39	Ejector Body	1	EJH-177-000
18	^{PM} Flange Gasket (two installed, two loose)	4	RH-477-000	40	Throat (1.687" Orifice)	1	EJH-171-1687
19	Bolt, 5/8"-11 x 8" Long	4	BTH-STA-282	41	Flange (3" Socket)* (four installed, two loose)	6	RH-1222
20	Throat Housing Assembly *	1	RH-893-000	^{PM}	Part & Maintenance Kit	1	KTH-3100-EJS
21	Handle	1	EJH-456-000	*	Flanges are 3 inch, four bolt, 150 lb., S (Van Stone style) in Schedule 80 PVC.		
22	^{PM} E-Clip	2	RH-997-000				



Date: October 2016

3" VARIABLE ORIFICE
FLANGED EJECTOR

Dwg. No.: EJH-3100-CL2, BOM

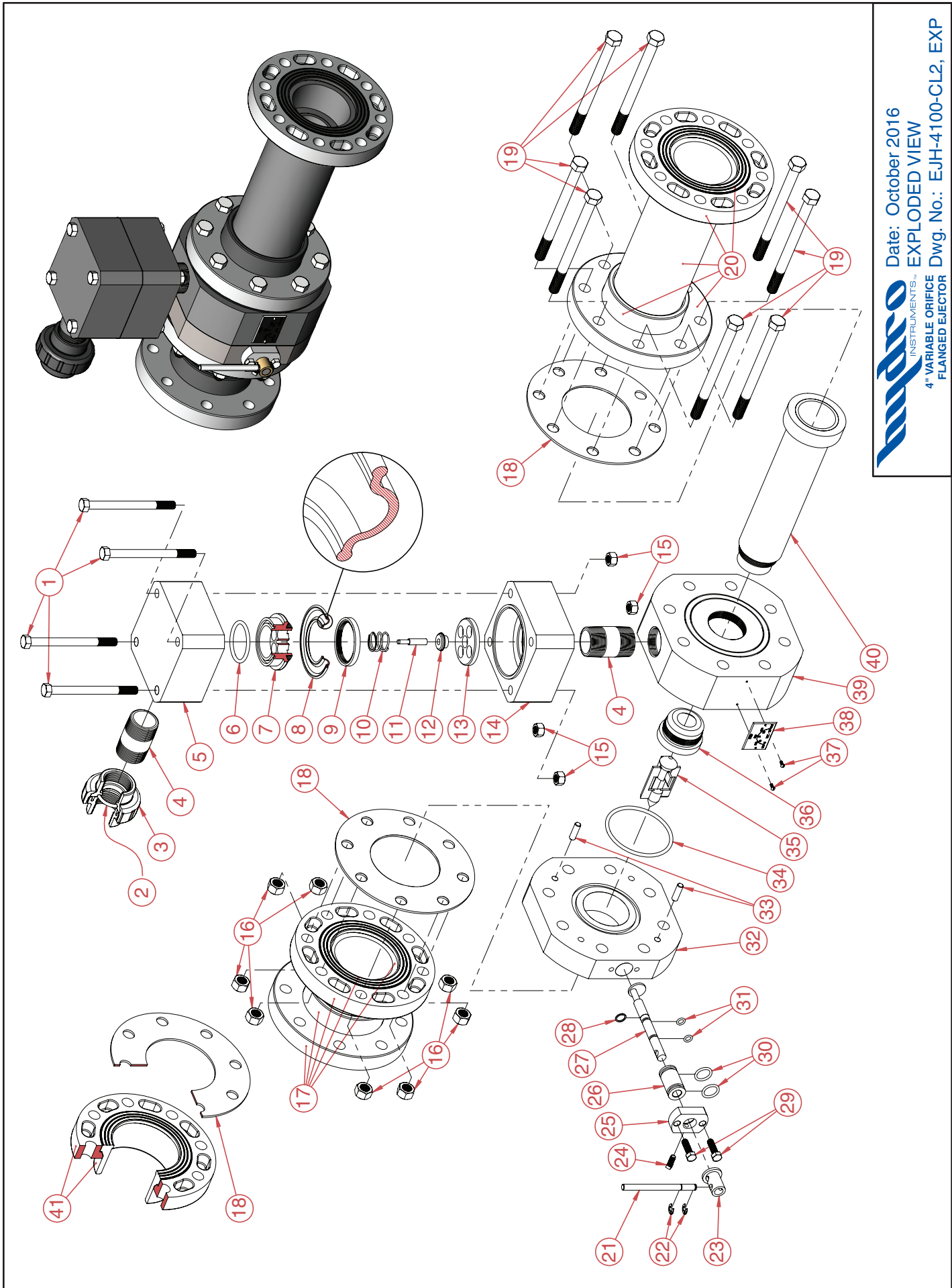



 Date: October 2016
 EXPLODED VIEW
 4" VARIABLE ORIFICE
 FLANGED EJECTOR Dwg. No.: EJH-4100-CL2, EXP

Item No.	Description	Quantity	Part No.	Item No.	Description	Quantity	Part No.
1	1/2"-13 x 6" Long Bolt	4	BTH-STA-191	23	Sleeve	1	EJH-451-000
2	^{PM} O-Ring	1	OH-VIT-328	24	Square Head Set Screw, 5/16"-18 x 3/4"	1	BTH-STA-237
3	1.5" Union	1	U-4298	25	Collar	1	EJH-453-000
4	1 1/2" x 3" Nipple	2	RH-481-000	26	Shaft Guide	1	EJH-898-000
5	Ejector Check Valve Top Body	1	EJH-175-000	27	Shaft Cam Assembly	1	EJH-389-000
6	^{PM} O-Ring	1	OH-CEM-331	28	Shaft Cam Ring	1	EJH-455-000
7	^{PM} Diaphragm Bolt	1	EJH-173-000	29	Hex Head Cap Screw, 3/8"-16 x 1 1/4"	2	BTH-STA-152
8	^{PM} Diaphragm	1	DIH-117-000	30	^{PM} O-Ring	2	OH-VIT-212
9	^{PM} Diaphragm Nut	1	EJH-178-000	31	^{PM} O-Ring	2	OH-VIT-110
10	Spring	1	SPH-115-000	32	Variable Orifice Body	1	EJH-196-000
11	Guide Pin	1	EJH-191-000	33	Dowel Pin	2	EJH-452-000
12	Pin Guide	1	EJH-190-000	34	^{PM} O-Ring	1	OH-VIT-345
13	Spring Retainer	1	EJH-172-000	35	Ejector Plug Assembly	1	EJH-364-000
14	Ejector Check Valve Bottom Body	1	EJH-174-000	36	Variable Nozzle	1	EJH-194-000
15	Nut, 1/2"-13 Hex	4	NTH-STA-192	37	Middle Body Plate Screw	2	EJH-784-000
16	Nut, 5/8"-11 Hex	8	NTH-STA-230	38	Middle Body Plate	1	EJH-111-000
17	Nozzle Housing Assembly *	1	RH-894-000	39	Ejector Body	1	EJH-179-000
18	^{PM} Flange Gasket (two installed, two loose)	4	RH-483-000	40	Throat (1.687" Orifice)	1	EJH-171-1687-1
19	Bolt, 5/8"-11 x 8" Long	8	BTH-STA-282	41	Flange (4" Socket)* (four installed, two loose)	6	RH-1223
20	Throat Housing Assembly *	1	RH-895-000	^{PM}	Part & Maintenance Kit	1	KTH-4100-EJS
21	Handle	1	EJH-456-000	*	Flanges are 4 inch, eight bolt, 150 lb., S (Van Stone style) in Schedule 80 PVC.		
22	^{PM} E-Clip	2	RH-997-000				

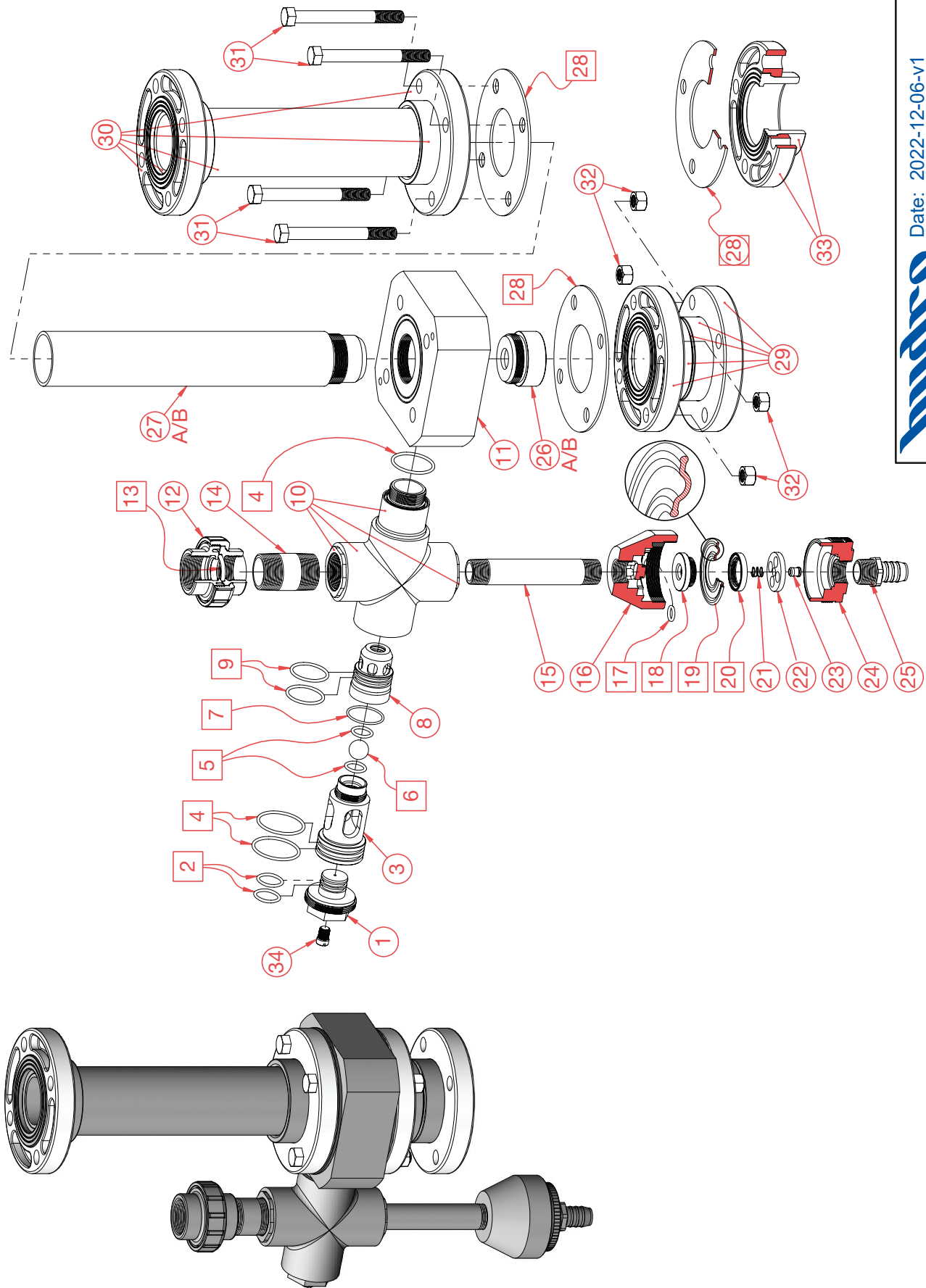

Date: October 2016
 INSTRUMENTS- BILL OF MATERIALS
 4" VARIABLE ORIFICE DWG. No.: EJH-4100-CL2, BOM
 FLANGED EJECTOR



Item No.	Description	Quantity	Part No.	Item No.	Description	Quantity	Part No.
1	Ball Check Valve, Part A4	1	EJH-BCV3-A40	21	Spring	1	SPH-100-000
2	^{PM} O-Ring	2	OH-VIT-216	22	Spring Retainer	1	EJH-164-000
3	Ball Check Valve, Part A3	1	EJH-BCV3-A30	23	Spring Guide	1	EJH-151-000
4	^{PM} O-Ring	3	OH-VIT-225	24	Drain Valve Bottom Body with Insert	1	WDV-167-000
5	^{PM} O-Ring	2	OH-VIT-212	25	1" PVC Barbed Insert Adapter	1	1436-010
6	^{PM} Ball Check Valve, 1" Diameter PVC Ball	1	CB-1000-PVC	26 A	Ejector Nozzle	1	EJH-185X-0953
7	^{PM} O-Ring	1	OH-VIT-132	26 B	Ejector Nozzle	1	EJH-185X-1078
8	Ball Check Valve, Part A2	1	EJH-BCV3-A20	27 A	Ejector Throat	1	EJH-171X-1250
9	^{PM} O-Ring	2	OH-VIT-224	27 B	Ejector Throat	1	EJH-171X-1593
10	Schedule 80 Cross with Inserts	1	EJH-BCV3-ACR	28	^{PM} Flange Gasket (two installed, two loose)	4	RH-477-000
11	Ejector Body (3" Ejector)	1	EJH-177-BCVA	29	Nozzle Housing Assembly*	1	RH-892X-000
12	1.5" Union	1	U-4298	30	Throat Housing Assembly*	1	RH-893X-000
13	^{PM} O-Ring (for 1.5" Union)	1	OH-VIT-328	31	Bolt, 5/8" - 11 x 6" Long	4	BTH-STA-241
14	1 1/2" NPT x 3" Nipple	1	RH-481-000	32	Nut, 5/8" - 11 Hex	4	NTH-STA-230
15	1" NPT x 7" Nipple	1	884-070	33	Flange (3" Socket)* (four installed, two loose)	6	RH-1222
16	Drain Valve Top Body	1	WDV-168-000	34	1/4" NPT Plug (PVC)	1	PLH-108-250
17	^{PM} O-Ring	1	OH-CEM-207	^{PM}	Part & Maintenance Kit	1	KTH-3200-EJS
18	^{PM} Diaphragm Bolt	1	WDV-162-000	*	Flanges are 3 inch, four bolt, 150 lb., S (Van Stone style) in Schedule 80 PVC.		
19	^{PM} Diaphragm	1	DIH-116-000				
20	^{PM} Diaphragm Nut	1	EJH-163-000				



Date: 2022-12-06-v1
 BILL OF MATERIALS
 3" FLANGED EJECTOR
 WITH BALL CHECK VALVE AND DRAIN
 Dwg. No.: EJH-3200-CL2, BOM

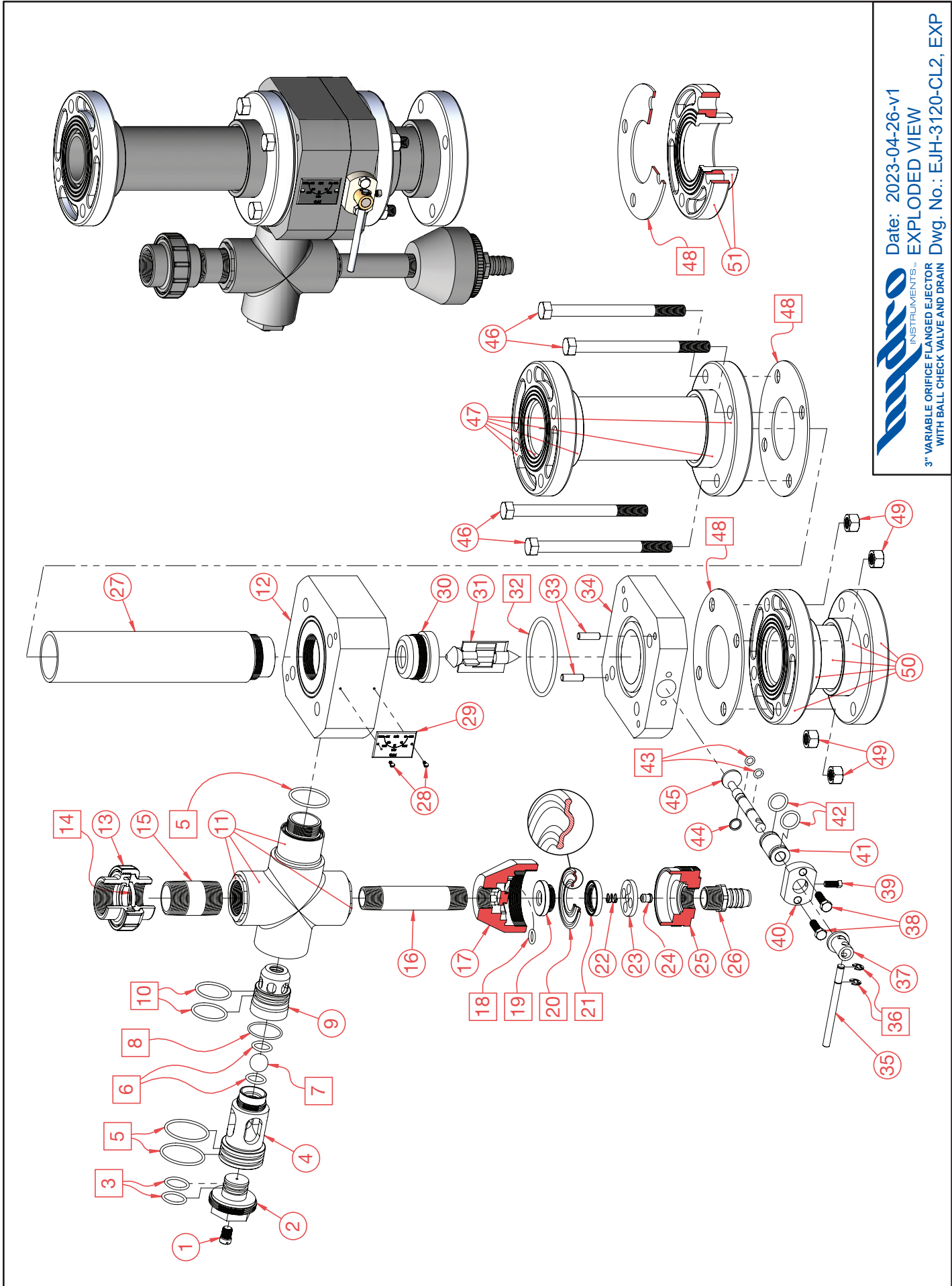

Item No.	Description	Quantity	Part No.	Item No.	Description	Quantity	Part No.
1	1/4" NPT Plug (PVC)	1	PLH-108-250	29	Middle Body Plate	1	EJH-111-000
2	Ball Check Valve, Part A4	1	EJH-BCV3-A40	30	Variable Nozzle	1	EJH-194-000
3	^{PM} O-Ring	2	OH-VIT-216	31	Ejector Plug Assembly	1	EJH-364-000
4	Ball Check Valve, Part A3	1	EJH-BCV3-A30	32	^{PM} O-Ring	1	OH-VIT-345
5	^{PM} O-Ring	3	OH-VIT-225	33	Dowel Pin	2	EJH-452-000
6	^{PM} O-Ring	2	OH-VIT-212	34	Variable Orifice Body	1	EJH-195-000
7	^{PM} Ball Check Valve, 1" Diameter PVC Ball	1	CB-1000-PVC	35	Handle	1	EJH-456-000
8	^{PM} O-Ring	1	OH-VIT-132	36	^{PM} E-Clip	2	RH-997-000
9	Ball Check Valve, Part A2	1	EJH-BCV3-A20	37	Sleeve	1	EJH-451-000
10	^{PM} O-Ring	2	OH-VIT-224	38	Hex Head Cap Screw, 3/8"-16 x 1 1/4"	2	BTH-STA-152
11	Schedule 80 Cross with Inserts	1	EJH-BCV3-ACR	39	Square Head Set Screw, 5/16"-18 x 3/4"	1	BTH-STA-237
12	Ejector Body (3" Ejector)	1	EJH-177-BCVA	40	Collar	1	EJH-453-000
13	1.5" Union	1	U-4298	41	Shaft Guide	1	EJH-898-000
14	^{PM} O-Ring (for 1.5" Union)	1	OH-VIT-328	42	^{PM} O-Ring	2	OH-VIT-212
15	1 1/2" NPT x 3" Nipple	1	RH-481-000	43	^{PM} O-Ring	2	OH-VIT-110
16	1" NPT x 7" Nipple	1	884-070	44	Shaft Cam Ring	1	EJH-455-000
17	Drain Valve Top Body	1	WDV-168-000	45	Shaft Cam Assembly	1	EJH-365-000
18	^{PM} O-Ring	1	OH-CEM-207	46	Bolt, 5/8"-11 x 8" Long	4	BTH-STA-282
19	^{PM} Diaphragm Bolt	1	WDV-162-000	47	Throat Housing Assembly*	1	RH-893-000
20	^{PM} Diaphragm	1	DIH-116-000	48	^{PM} Flange Gasket (two installed, two loose)	4	RH-477-000
21	^{PM} Diaphragm Nut	1	EJH-163-000	49	Nut, 5/8"-11 Hex	4	NTH-STA-230
22	Spring	1	SPH-100-000	50	Nozzle Housing Assembly*	1	RH-892-000
23	Spring Retainer	1	EJH-164-000	51	Flange (3" Socket)* (four installed, two loose)	6	RH-1222
24	Spring Guide	1	EJH-151-000				
25	Drain Valve Bottom Body with Insert	1	WDV-167-000	^{PM}	Part & Maintenance Kit	1	KTH-3120-EJS
26	1" PVC Barbed Insert Adapter	1	1436-010	*	Flanges are 3 inch, four bolt, 150 lb., S (Van Stone style) in Schedule 80 PVC.		
27	Throat (1.687" Orifice)	1	EJH-171-1687				
28	Middle Body Plate Screw	2	EJH-784-000				



Date: 2023-04-26-v1

BILL OF MATERIALS

3" VARIABLE ORIFICE FLANGED EJECTOR WITH BALL CHECK VALVE AND DRAIN Dwg. No.: EJH-3120-CL2, BOM

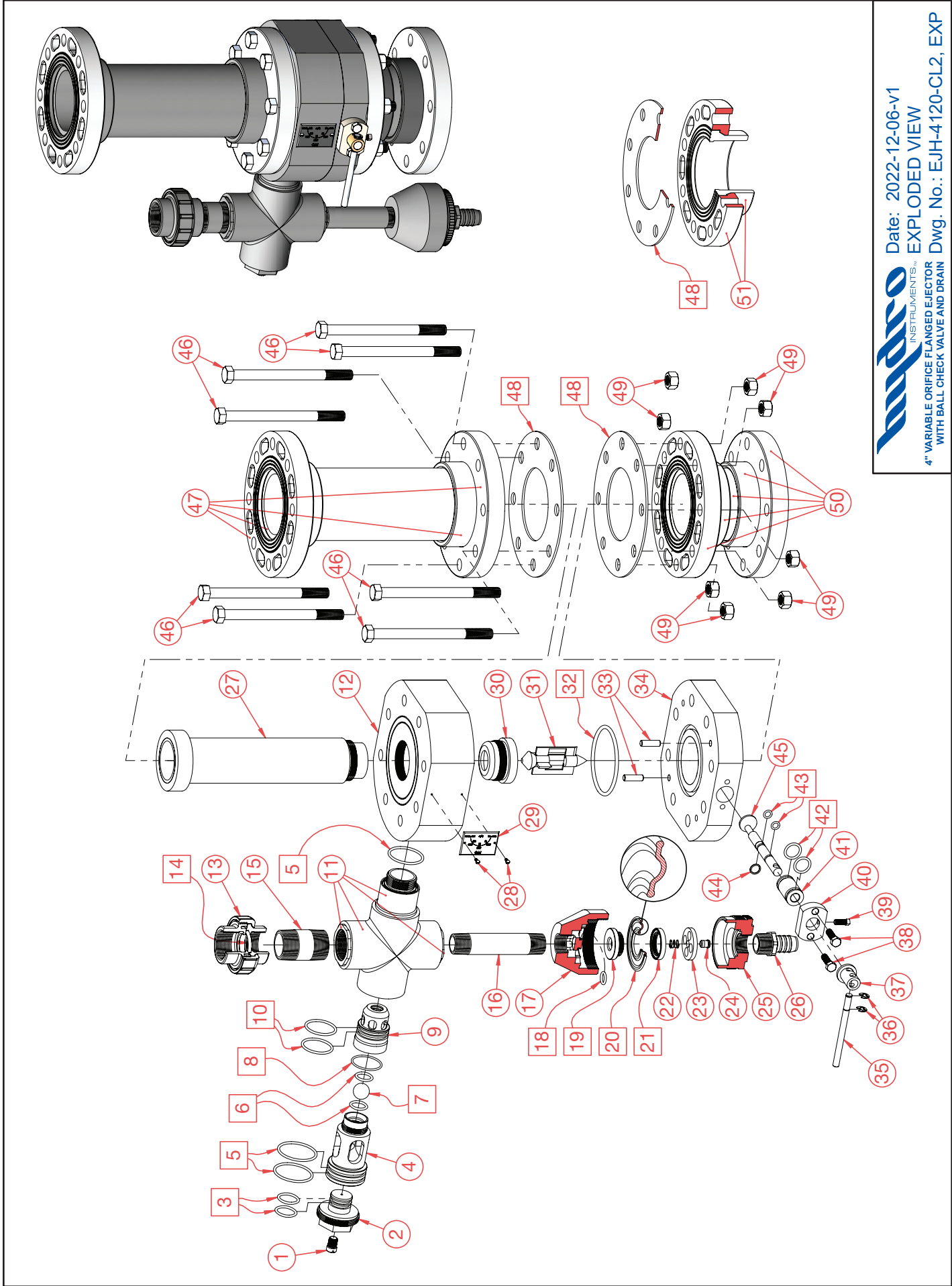

Date: 2022-12-06-v1
EXPLODED VIEW
4" VARIABLE ORIFICE FLANGED EJECTOR
WITH BALL CHECK VALVE AND DRAIN
Dwg. No.: EJH-4120-CL2, EXP

Item No.	Description	Quantity	Part No.	Item No.	Description	Quantity	Part No.
1	1/4" NPT Plug (PVC)	1	PLH-108-250	29	Middle Body Plate	1	EJH-111-000
2	Ball Check Valve, Part A4	1	EJH-BCV3-A40	30	Variable Nozzle	1	EJH-194-000
3	^{PM} O-Ring	2	OH-VIT-216	31	Ejector Plug Assembly	1	EJH-364-000
4	Ball Check Valve, Part A3	1	EJH-BCV3-A30	32	^{PM} O-Ring	1	OH-VIT-345
5	^{PM} O-Ring	3	OH-VIT-225	33	Dowel Pin	2	EJH-452-000
6	^{PM} O-Ring	2	OH-VIT-212	34	Variable Orifice Body	1	EJH-196-000
7	^{PM} Ball Check Valve, 1" Diameter PVC Ball	1	CB-1000-PVC	35	Handle	1	EJH-456-000
8	^{PM} O-Ring	1	OH-VIT-132	36	^{PM} E-Clip	2	RH-997-000
9	Ball Check Valve, Part A2	1	EJH-BCV3-A20	37	Sleeve	1	EJH-451-000
10	^{PM} O-Ring	2	OH-VIT-224	38	Hex Head Cap Screw, 3/8"-16 x 1 1/4"	2	BTH-STA-152
11	Schedule 80 Cross with Inserts	1	EJH-BCV3-ACR	39	Square Head Set Screw, 5/16"-18 x 3/4"	1	BTH-STA-237
12	Ejector Body (4" Ejector)	1	EJH-179-BCVA	40	Collar	1	EJH-453-000
13	1.5" Union	1	U-4298	41	Shaft Guide	1	EJH-898-000
14	^{PM} O-Ring (for 1.5" Union)	1	OH-VIT-328	42	^{PM} O-Ring	2	OH-VIT-212
15	1 1/2" NPT x 3" Nipple	1	RH-481-000	43	^{PM} O-Ring	2	OH-VIT-110
16	1" NPT x 7" Nipple	1	884-070	44	Shaft Cam Ring	1	EJH-455-000
17	Drain Valve Top Body	1	WDV-168-000	45	Shaft Cam Assembly	1	EJH-389-000
18	^{PM} O-Ring	1	OH-CEM-207	46	Bolt, 5/8"-11 x 8" Long	8	BTH-STA-282
19	^{PM} Diaphragm Bolt	1	WDV-162-000	47	Throat Housing Assembly*	1	RH-895-000
20	^{PM} Diaphragm	1	DIH-116-000	48	^{PM} Flange Gasket (two installed, two loose)	4	RH-477-000
21	^{PM} Diaphragm Nut	1	EJH-163-000	49	Nut, 5/8"-11 Hex	8	NTH-STA-230
22	Spring	1	SPH-100-000	50	Nozzle Housing Assembly*	1	RH-894-000
23	Spring Retainer	1	EJH-164-000	51	Flange (4" Socket)* (four installed, two loose)	6	RH-1223
24	Spring Guide	1	EJH-151-000				
25	Drain Valve Bottom Body with Insert	1	WDV-167-000	^{PM}	Part & Maintenance Kit	1	KTH-4120-EJS
26	1" PVC Barbed Insert Adapter	1	1436-010	*	Flanges are 4 inch, eight bolt, 150 lb., S (Van Stone style) in Schedule 80 PVC.		
27	Throat (1.687" Orifice)	1	EJH-171-1687-1				
28	Middle Body Plate Screw	2	EJH-784-000				



Date: 2022-12-06-v1

BILL OF MATERIALS

4" VARIABLE ORIFICE FLANGED EJECTOR WITH BALL CHECK VALVE AND DRAIN Dwg. No.: EJH-4120-CL2, BOM