

Operating Instructions

DULCOMETER® D1C

Part 2: Adjustment and Operation,
Measured Variable Standard Signal

D1C2-mA-001-GB



Type D



Type W

D1C A _____

Please enter the identity code of your device here!

**Please completely read through operating instructions! · Do not discard!
The warranty shall be invalidated by damage caused by operating errors!**

2 General User Information

	Page
1 Device Identification / Identity Code	2
2 General User Information	3
3 Device Overview / Controls	4
4 Functional Description	5
5 Display Symbols	6
6 Operation diagram	7
7 Restricted Operating Menu	8
Layout	8
Description	9
8 Complete Operating Menu	12
Overview	12
Description	13
9 Faults/Notes/Troubleshooting	24

General User Information

These operating instruction describe the technical data and function of the series DULCOMETER® D1C controller, provide detailed safety information and are divided into clear steps.



IMPORTANT

- ***Please observe the parts of these operating instructions applicable to your particular version! This is indicated in the Section “Device Identification / Identity Code”!***
- ***Correct measuring and metering is only possible in the case of impeccable operation of the sensor. The sensor has to be calibrated / checked regularly!***

NOTE

A form “Documentation of controller settings type D1C” is available under www.prominent.com/documentation_D1C for the purpose of documenting the controller settings.

3 Device Overview / Controls

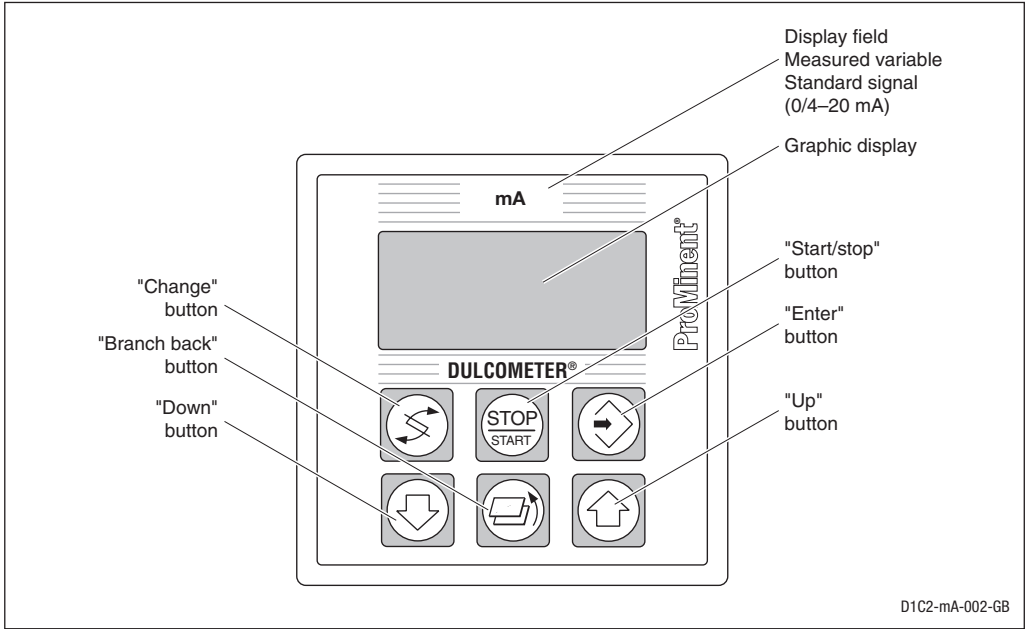

	<p>CHANGE button</p> <p>To change over within a menu level and to change from one variable to another within a menu point.</p>
	<p>START/STOP button</p> <p>Start/stop of control and metering function.</p>
	<p>ENTER button</p> <p>To accept, confirm or save a displayed value or status. For alarm acknowledgement.</p>

	<p>UP button</p> <p>To increase a displayed numerical value and to change variables (flashing display)</p>
	<p>BRANCH BACK button</p> <p>Back to permanent display or start of relevant setting menu.</p>
	<p>DOWN button</p> <p>To decrease a displayed numerical value and to change variables (flashing display).</p>

4 Functional Description

NOTE

Please refer to the description of the complete operating menu in Section 8 for a detailed description of the individual characteristics of the D1C controller!

4.1 Operating Menu

The DULCOMETER® D1C controller permits settings to be made in two different menus – a “complete” and a “restricted” menu. All values are preset and can be changed in the **complete** operating menu.

The controller is delivered with a **restricted** operating menu so that the D1C controller can be used effectively in many applications from the very onset. If adaptations prove to be necessary, all relevant parameters can then be accessed by switching over to the complete operating menu (see “General settings”).

4.2 Access Code

Access to the setting menu can be prevented by setting up an access code. The D1C controller is supplied with the access code 5000 which permits free access to the setting menu. The calibration menu remains freely accessible even if access to the setting menu is blocked by the code.

4.3 Control

The D1C can operate as a proportional controller or as a PID controller - depending on the device version (see identity code) and the setting.

The controlled variable is recalculated once a second. Control procedures which require rapid correction of setpoint deviations (less than approx. 30 seconds) cannot be processed with this controller. The cycle times must be taken into consideration when activating solenoid valves (pulse length) in the same way as their running times when activating servomotors (3-point).

Via the control input pause, the control function (selection of controlled variable) can be switched off. The calculation of the controlled variable starts again after cessation of "pause".

4.4 Feed Forward Control

The D1C controller can process a signal of a feed forward control. Depending on the device version (see identity code) and the setting, this signal can be obtained in any form of a 0–20 mA or 4–20 mA signal or as a digital contact signal with the maximum frequencies 10 Hz or 500 Hz.

This signal can be used, for example, for flow-proportional metering (multiplicative effect) or feedforward-dependent basic load metering (additive effect). The result of control variable calculation from the proportional or PID control is multiplied by or added to the feedforward signal. A multiplicative feedforward variable at the level of the set rated value carries over the calculated control variable unchanged into the controlled variable:

$$\text{Controlled variable} = \text{Feedforward variable} / \text{rated value} \times \text{calculated control variable}$$

During start-up, the zero point has to be checked. The multiplicative feed forward control is not designed for switching off permanently the actuating variable (signal ≈ 0).

An additive feedforward variable at the level of the rated value results in maximum controlled variable:



























$$\text{Controlled variable (max. 100 \%)} = \text{Feedforward variable} / \text{rated value} \times \text{max. controlled variable} + \text{calculated control variable}$$

4.5 Error Messages

Error messages and information are indicated on the bottom line in the permanent display 1. Errors to be acknowledged (acknowledgement switches off the alarm relay) are indicated by the "E". Errors/notes which still apply after acknowledgement are indicated alternately. Faults which are rectified of their own accord due to changed operating situations are removed from the permanent display without the need for acknowledgement.

5 Display Symbols

The display of the DULCOMETER® D1C controller uses the following symbols:

Description	Comment	Symbol
Limit value transgression Relay 1, upper	Symbol left	
Relay 1, lower	Symbol left	
Relay 2, upper	Symbol right	
Relay 2, lower	Symbol right	
Metering pump 1  Control off	Symbol left	
Control on	Symbol left	
Metering pump 2  Control off	Symbol right	
Control on	Symbol right	
Solenoid valve 1  Control off	Symbol left	
Control on	Symbol left	
Solenoid valve 2  Control off	Symbol right	
Control on	Symbol right	
Servomotor Control, open relay		 
Control, close relay		 
Without control		 
Position feedback	The bar increases from left to right during opening	
Stop button pressed		
Manual metering		
Fault		

6 Operation diagram

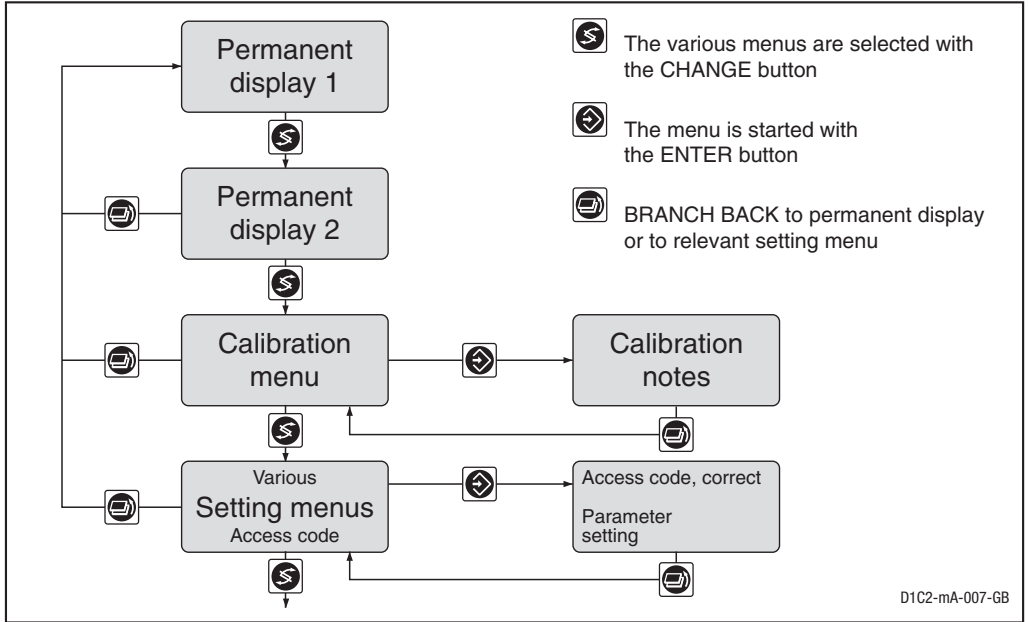

NOTE

Access to the setting menus can be barred with the access code!

The number and scope of setting menus depends on the device version!

If the access code is selected correctly in a setting menu, the following setting menus are also accessible!

If within a period of 10 minutes no button is pushed, the unit automatically branches back from the calibrating menu or a setting menu to the permanent display 1.

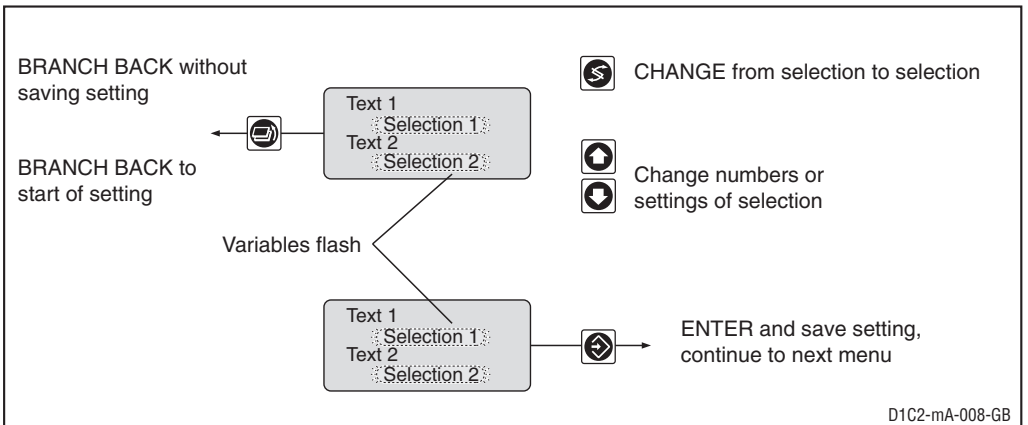

7 Restricted Operating Menu / Layout

The restricted operating menu permits simple operation of the most important parameters. The following overview shows the settings which can be selected:

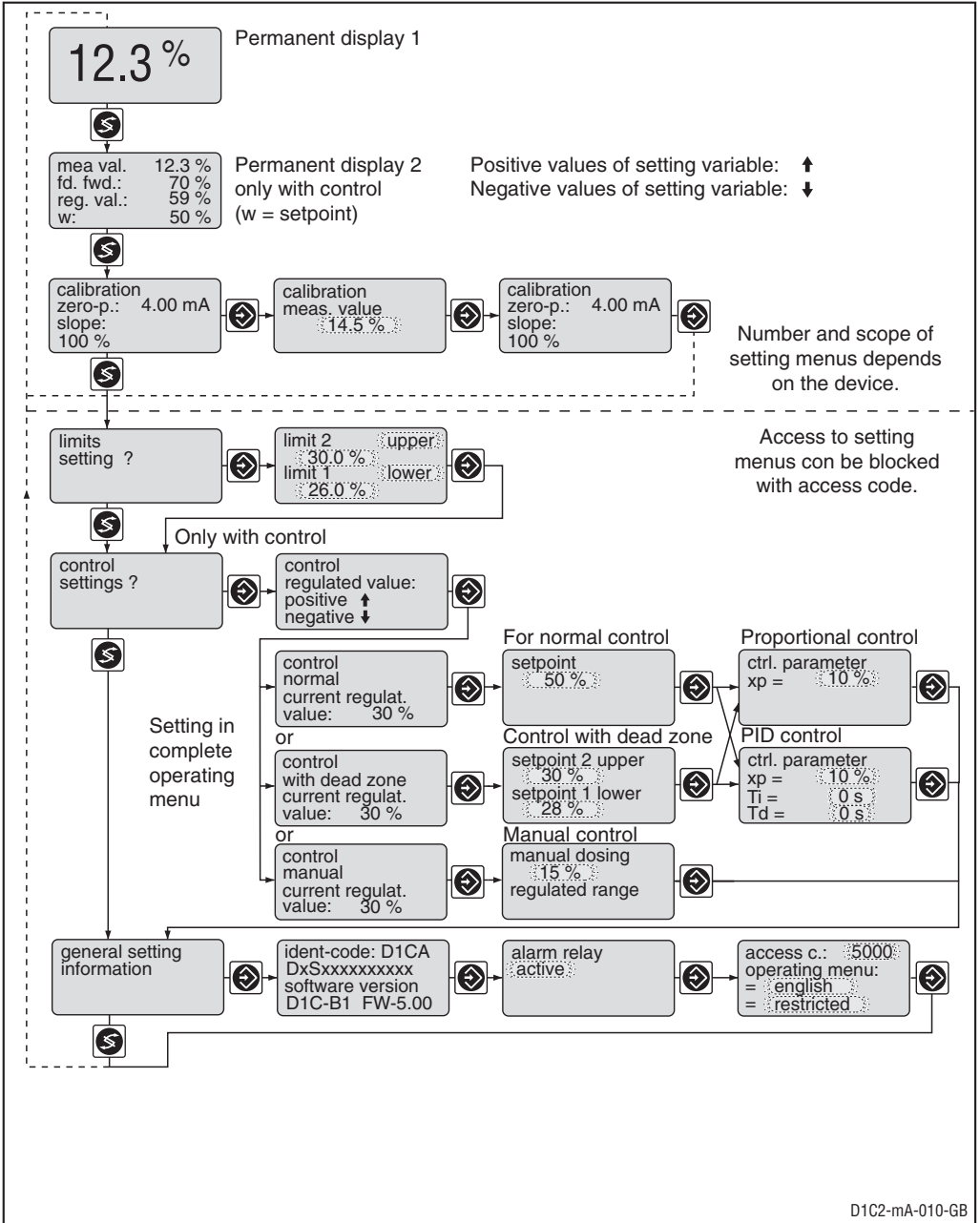

Restricted Operating Menu / Description

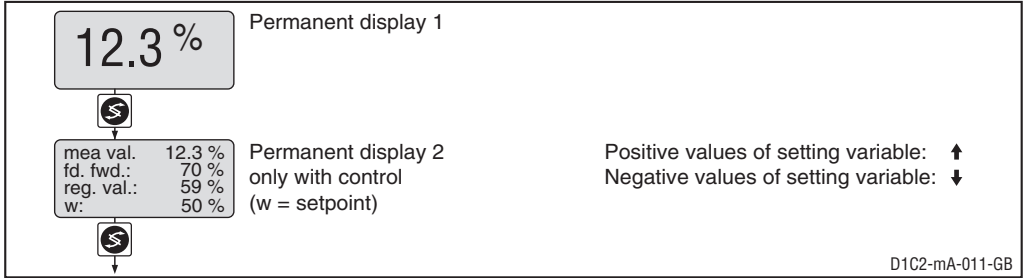

Calibration of the standard signal (zero-point calibration)

The D1C sets the control output to “0” during the calibration procedure. Exception: When a basic load or a manual control variable is set the corresponding parameter is retained during calibration. The standard signals outputs mA (measured value) are frozen. The measured value frozen at the start of calibration is the proposed value. This value is adjustable (arrow buttons!). Calibration is possible only when the value is ≥ 2 % of the measuring range. Following successful calibration, all troubleshooting procedures relating to the measured value are restarted.



IMPORTANT

*The measuring range of the sensor must agree with the set measuring range.
The unit of measure must be set prior to calibration (see Page 14)!*

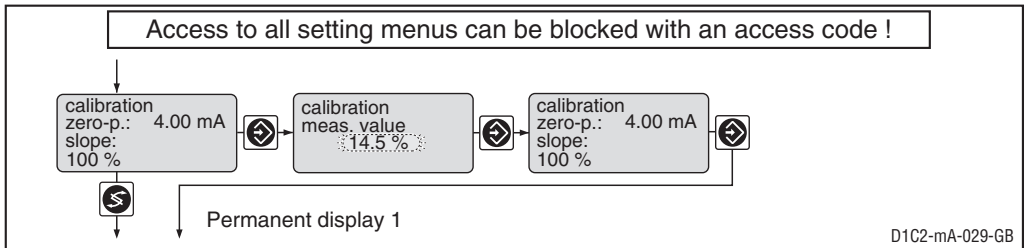

	Initial value	Possible values			Remarks
		Increment	Lower value	Upper value	
Measured value		0.1 %	-5 %	105 %	
		0.01 mA	-1.00 mA	21.00 mA	
		0.01 m	0 m	31.50 m	30.00 m
		0.1 %	0 %	105 %	100 %
		0.001 bar	0 bar	1.050 bar	1.000 bar
		0.001 bar	0 bar	5.250 bar	5.000 bar
		0.01 bar	0 bar	10.50 bar	10.00 bar
		0.1 bar	0 bar	105 bar	100.0 bar
		0.1 psi	0 psi	105 psi	100 psi
		1 psi	0 psi	1050 psi	1000 psi
		0.001 m ³ /h	0 m ³ /h	9.999 m ³ /h	9.999 m ³ /h
		0.1 m ³ /h	0 m ³ /h	105 m ³ /h	100 m ³ /h
		1 m ³ /h	0 m ³ /h	1050 m ³ /h	1000 m ³ /h
		0.1 gal/h	0 gal/h	105 gal/h	100 gal/h
		1 gal/h	0 gal/h	1050 gal/h	1000 gal/h
		1 ppm	0 ppm	1050 ppm	1000 ppm
0.1 %RH	0 %RH	105 %RH	100 %RH		
0.01 mA	0/4 mA	21 mA	20 mA		
0.1 %	0 %	105 %	100 %		

Restricted Operating Menu / Description

Limit values

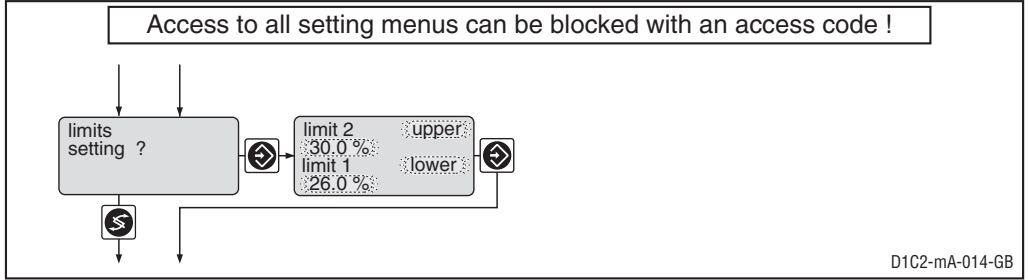

	Initial value	Possible values			Remarks
		Increment	Lower value	Upper value	
Type of limit transgression	Limit 1: lower Limit 2: upper	upper lower off*			Limit transgression when exceeding or dropping below value *only with limit value relay
Limit value	Limit 1: 0 % Limit 2: 100 % Limit 1: 0.00 mA Limit 2: 20.00 mA	0.1 % 0.1 % 0.01 mA 0.01 mA	-5 % -5 % -1.00 mA -1.00 mA	105 % 105 % 21 mA 21 mA	

Control

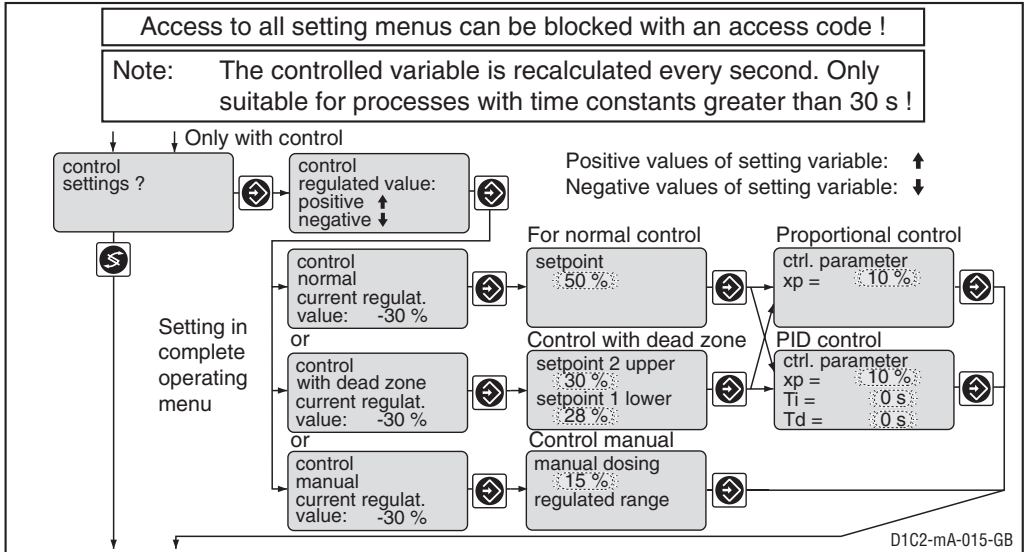

Restricted Operating Menu / Description

	Initial value	Possible values			Remarks
		Increment	Lower value	Upper value	
Setpoint	50 % 10.00 mA	0.1 % 0.01 mA	-5.0 % -1.00 mA	105 % 21 mA	Measuring unit: % Measuring unit: mA 2 setpoints necessary for control with dead zone. Setpoint 1 ≤ setpoint 2
Control parameter xp	10 %	1 %	1 %	500 %	xp referred to measuring range
Control parameter Ti	off	1 s	1 s	9999 s	range
Control parameter Td	off	1 s	1 s	2500 s	Function off = 0 s
Manual metering	0 %	1 %	-100 %	+100 %	Function off = 0 s

Abbreviation for control variables:

x_p = 100 %/Kp (inverse proportional coefficient)

T_i = I controller integration time [s]

T_d = D controller differential time [s]

General settings

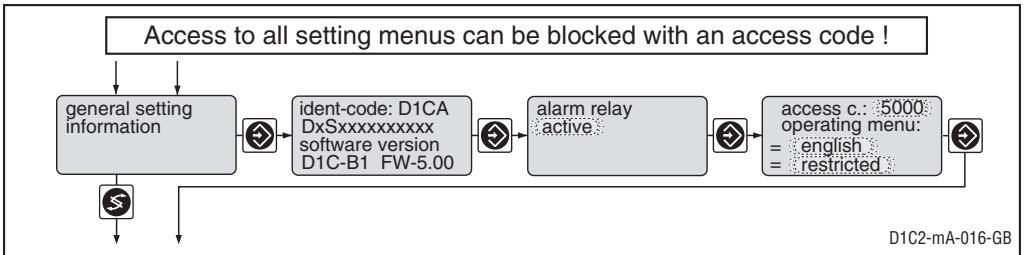

	Initial value	Possible values			Remarks
		Increment	Lower value	Upper value	
Alarm relay	active	active not active			
Access code	5000	1	1	9999	
Language	as per identity code	as per identity code			
Operating menu	restricted	restricted complete			

8 Complete Operating Menu / Overview

All parameters of the controller can be set in the complete operating menu (access see previous page). The following overview shows the settings which can be selected:

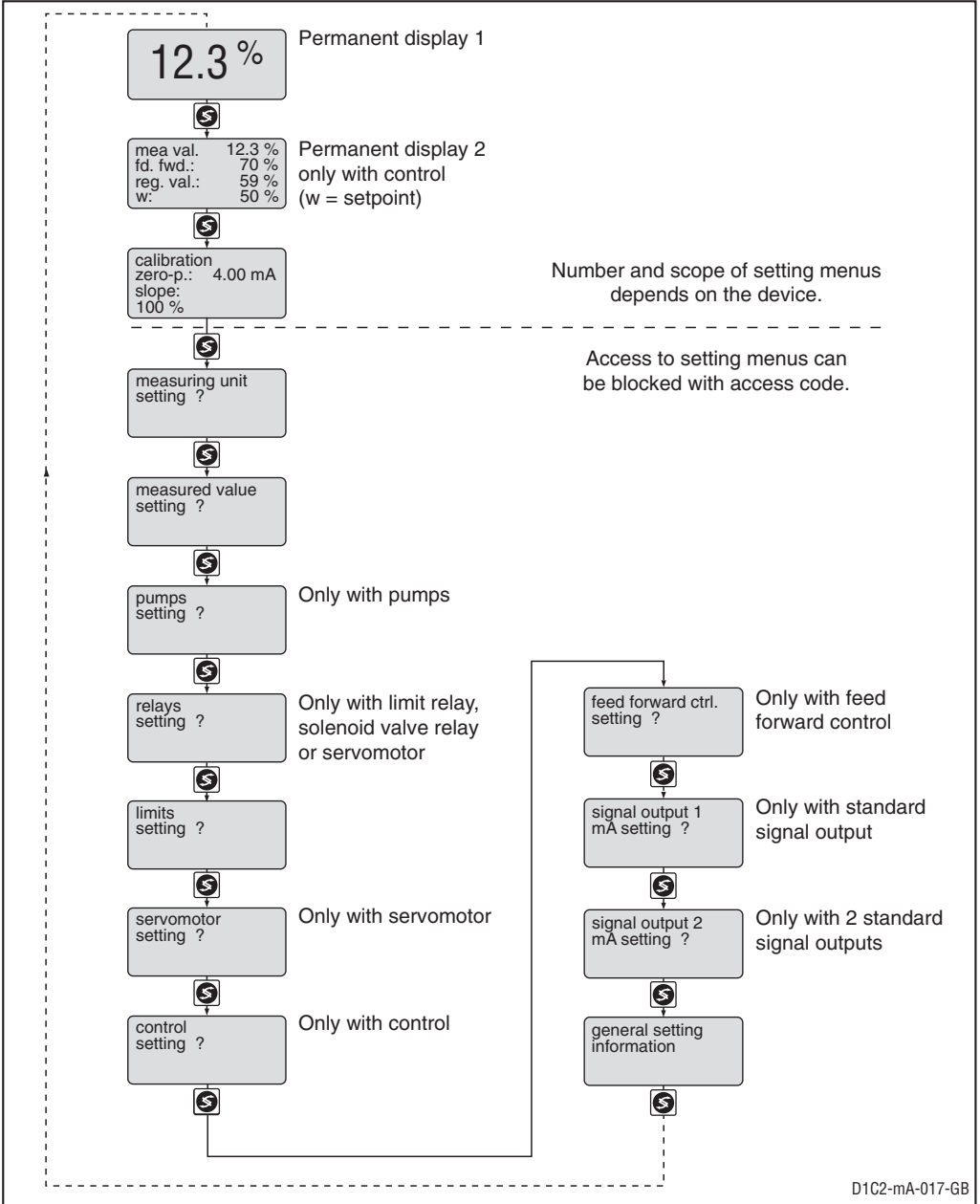

Complete Operating Menu / Description

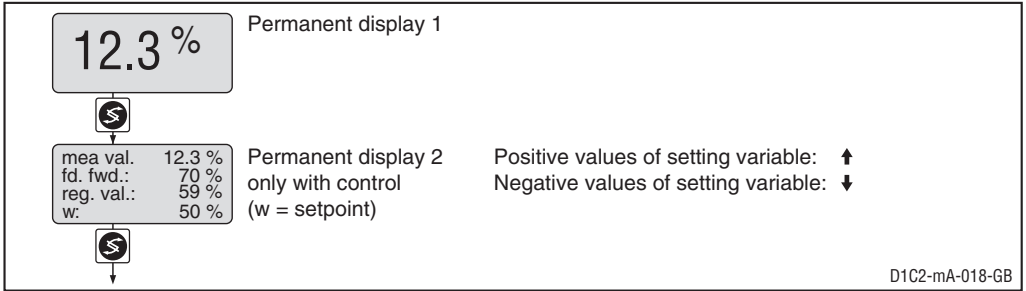

Calibration of the standard signal (two-point calibration)

The D1C sets the control output to “0” during the calibration procedure. Exception: When a basic load or a manual control variable is set the corresponding parameter is retained during calibration. The standard signals outputs mA (measured value) are frozen. The measured value frozen at the start of calibration is the proposed value. This value is adjustable (arrow buttons!). Calibration is possible only when the value is ≥ 2 % of the measuring range. Following successful calibration, all troubleshooting procedures relating to the measured value are restarted.



IMPORTANT

**The measuring range of the sensor must agree with the set measuring range.
The unit of measure must be set prior to calibration (see Page 14)!**

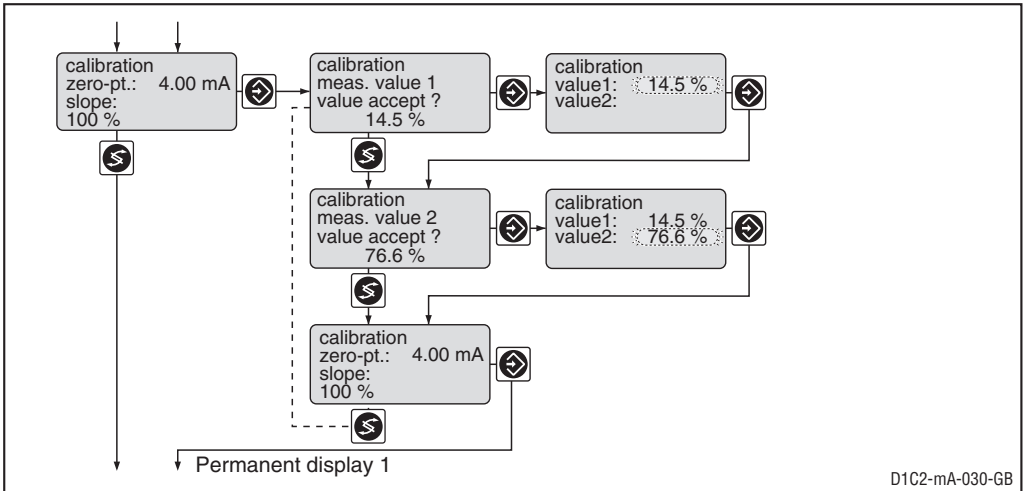

	Initial value	Possible values		Remarks	
	Measured value*	Increment	Lower value		Upper value
		0.1 % 0.01 mA	-5 % -1.00 mA	105 % 21.00 mA	*for possible measuring values see page 9

Error message	Condition	Effect
Value distance too small	Δ value > 5.0 % Δ value > 1.00 mA	Measured value deleted Repeat calibration of measuring point

Complete Operating Menu / Description

Measuring variable

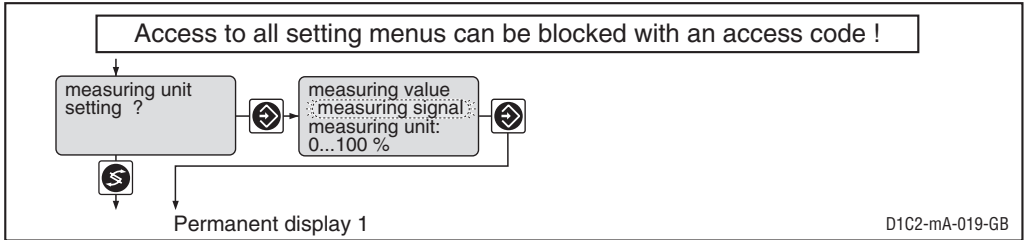

! **IMPORTANT**
The sensor must be recalibrated and the settings in all the menus checked after changing the assigned range!

	Initial value	Possible values			Remarks
		Increment	Lower value	Upper value	
Measuring variable	Measurement signal	Level Pressure Water flow rate Turbidity Humidity Measurement signal			
Measuring unit	0 - 100 %	0 - 30 m 0 - 100 % 0 - 1.000 bar 0 - 5.000 bar 0 - 10.00 bar 0 - 100.0 bar 0 - 100.0 psi 0 - 1000 psi 0 - 9.999 m ³ /h 0 - 100.0 m ³ /h 0 - 1000 m ³ /h 0 - 100.0 gal/h 0 - 1000 gal/h 0 - 1000 ppm 0 - 100.0 %RH 0/4 - 20 mA 0 - 100 %			Level Pressure Water flow rate Turbidity Humidity Measurement signal

! **IMPORTANT**
The setpoint and limit values are changed over to the corresponding initial values when the measuring range is changed! Check the settings in all menus!

Complete Operating Menu / Description

Measured value

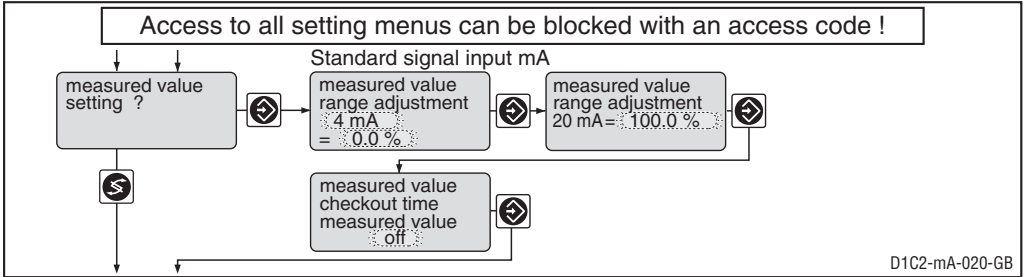

IMPORTANT

When changing the range adjustment, the sensor must be newly calibrated and the adjustments in all menus have to be checked!

	Initial value	Possible values			Remarks
		Increment	Lower value	Upper value	
Standard signal input lower signal limit	4 mA	0 mA 4 mA			
Allocated measuring range*	0-100.0 % 0-20.00 mA	0.1 % 0.01 mA	-5 % -1.00 mA	105 % 21.00 mA	Measurement signal *for other measuring ranges see page 9
Checkout time	off	1 s	1 s	9999 s	Constant measurement signal results in message and alarm. Function off = 0 s

Measured value checkout time



IMPORTANT

This function may not be activated for applications in which it can be assumed that the measured value will not change.

This function tests whether the measured value changes from that of the sensor (at the measured value input) within the “Measured value checkout time”. It is assumed that it will do so for an intact sensor.

If the measuring value does not change during this checkout time, the DULCOMETER® D1C sets the control variable to “0” and the alarm relay drops out. The LCD display shows e.g. the message “limit 1/2”.

Pumps

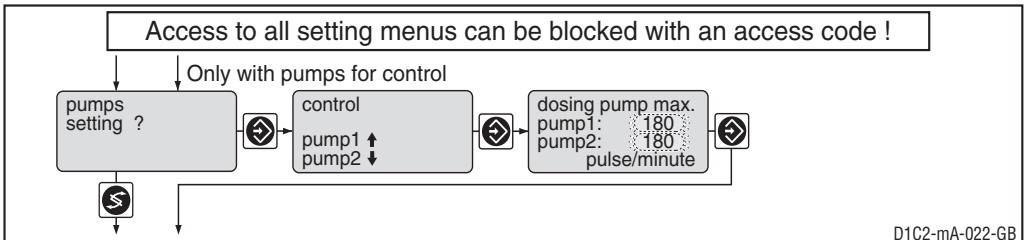

	Initial value	Possible values			Remarks
		Increment	Lower value	Upper value	
Max. stroke/minute of pumps 1 and 2	180	1	1	500	off = 0 strokes/min

Complete Operating Menu / Description

Relay for power control

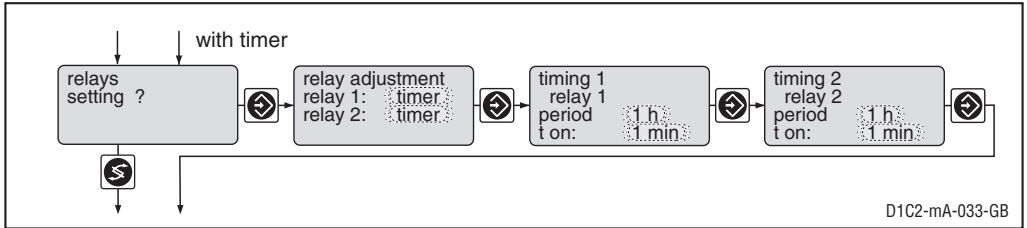
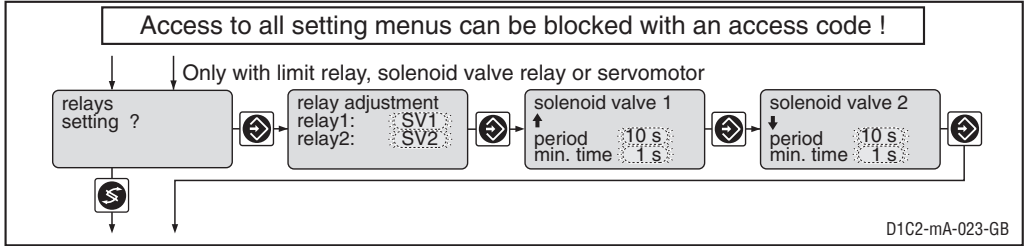

	Initial value	Possible values			Remarks
		Increment	Lower value	Upper value	
Relay adjustment Relay 1	as per identity code	Solenoid valve 1 Limit value 1* Actuator 1 Timer 1 Servomotor off			* At "limit value", the relays remain active even in the case of fault. Only with servomotor
Relay 2		Solenoid valve 2 Limit value 2* Actuator 2 Timer 2 off			
Period	10 s	1 s	10 s	9999 s	for solenoid valve
min. time	1 s	1 s	1 s	period/2	for solenoid valve
Period	off	1 h	1 h/off	240 h	for timer
t on	1 min	1 min	1 min	60 min	for timer

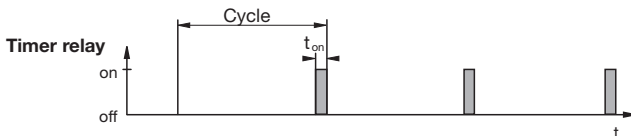

IMPORTANT

The timer will reset in the event of a power failure.

At the end of the (timer) cycle time the DULCOMETER® D1C closes the assigned relay for the duration of "t on" (timer). "Pause" interrupts the timer.

Complete Operating Menu / Description

When the clock is shown in the LC display the timer can be reset to the start of the cycle at precisely this point using the enter button.

The % figure in the LC display indicates the progress of the current cycle.

Timer relays may be used, e.g. for shock metering or sensor cleaning.

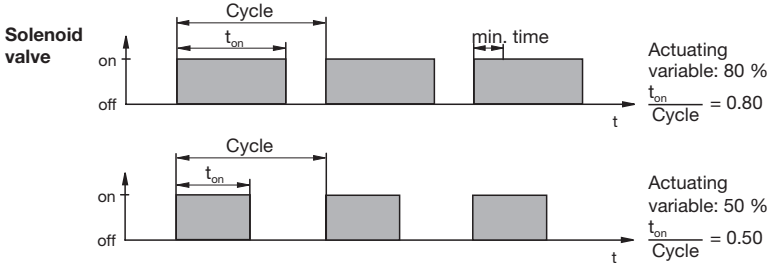

The switching time of the DULCOMETER® D1C (solenoid valve) depends on the actuating variable and the “min. time” (smallest permitted operating factor of the connected device). The actuating variable determines the ratio $t_{on}/cycle$ and thus the switching times (see fig. above).

The “min. time” influences the switching times in two situations:

a) theoretical switching time < min. time:

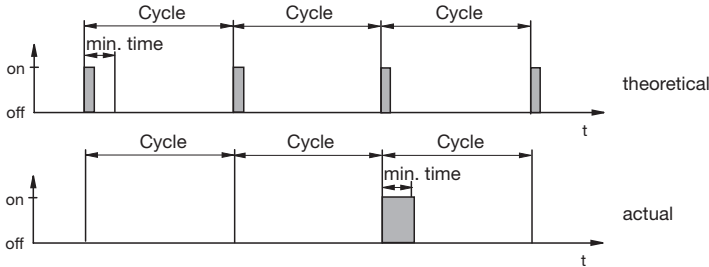

The DULCOMETER® D1C does not switch for a certain number of cycles until the sum of the theoretical switching times exceeds the “min. time”. Then the DULCOMETER® D1C switches for the duration of this total time.

b) theoretical switching time > (cycle - min. time) and calculated switching time < cycle

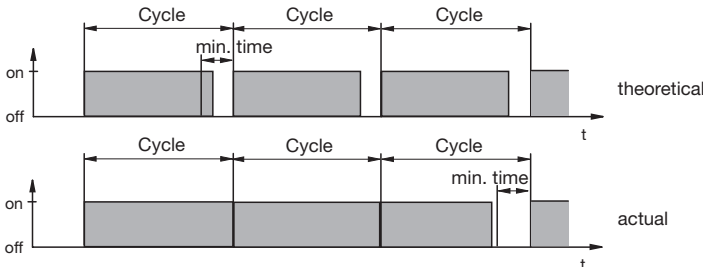

The DULCOMETER® D1C does not deactivate for a certain number of cycles until the differences between cycle and theoretical switching time exceed the “min. time”.

Complete Operating Menu / Description

Limit values

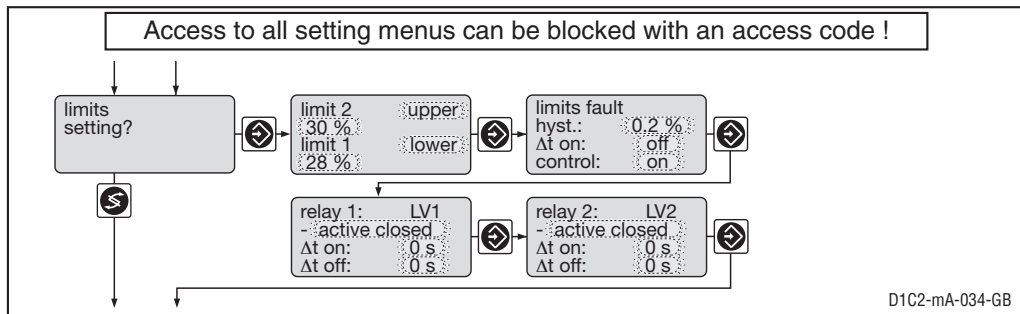

	Initial value	Possible values			Remarks
		Increment	Lower value	Upper value	
Type of limit transgression	Limit 1: lower Limit 2: upper	upper lower off*			Limit transgression when exceeding or dropping below value *only with limit value relay
Limit value	Limit 1: 0 % Limit 2: 100 %	0.1 % 0.1 %	-5 % -5 %	105 % 105 %	Measuring unit percent
	Limit 1: 0 mA Limit 2: 20 mA	0.01 mA 0.01 mA	-1.00 mA -1.00 mA	21 mA 21 mA	Measuring unit milliamper
Hysteresis limits	0.2 % 0.04 mA	0.1 % 0.01 mA	0.1 % 0.02 mA	105 % 21.00 mA	Active in "cancellation of limit transgression" direction
Checkout time limits	off	1 s	1 s	9999 s	Results in message and alarm. Off = 0 s: Function switched off, no message, no alarm
Control	on	on off			
Switching direction					
Limit value 1	active closed	active closed			Acts as N/O
Limit value 2		active open			Acts as N/C
Switch-on delay Δt on	0 s	1 s	0 s	9999 s	
Switch-off delay Δt off	0 s	1 s	0 s	9999 s	

If the limit transgression is applied longer than the "delay time limit values", an error message is triggered and the alarm relay drops out; the control procedure stops if "control" is additionally set to "off".

Complete Operating Menu / Description

Servomotor

The **operating range** is defined by the total resistance range of the feedback potentiometer. The maximum limit of the range actually used is set by defining the **control range**.



IMPORTANT

- **Activation of the servomotor must be carried out with the same meticulous care as taken when calibrating a measuring sensor.**
- **To ensure correct operation, the activation time of the actuator used should not be less than 25 seconds for the control range from 0...100 %!**

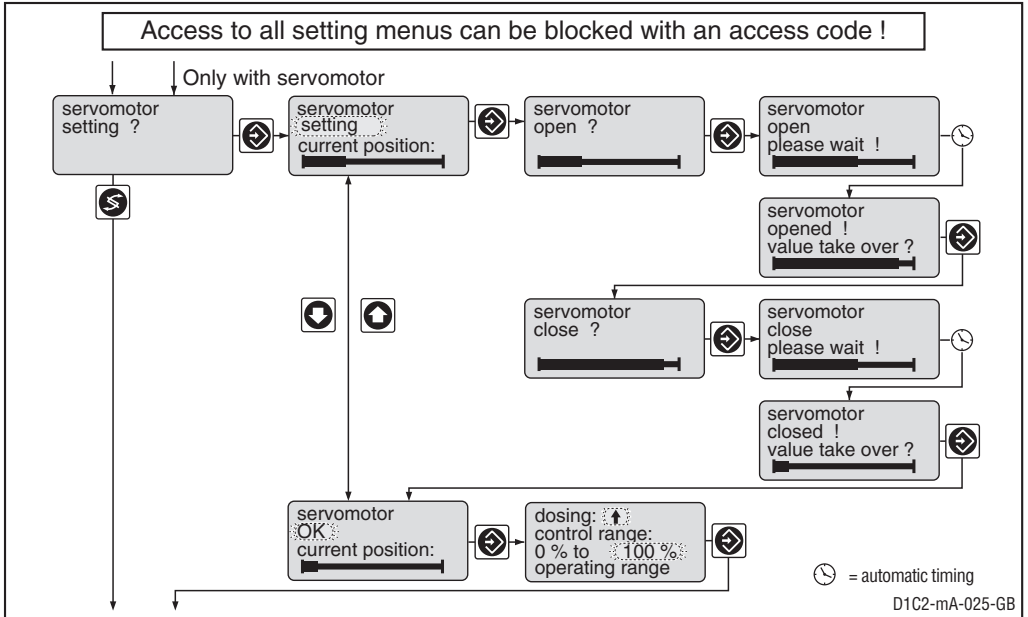

	Initial value	Possible values			Remarks
		Increment	Lower value	Upper value	
Servomotor	Setting	Setting ok off			
Control direction	↑	↑ ↓			
Control range	100 %	1 %	10 %	100 %	in % of operating range

NOTE

- **When the wide bar is as right as it will go, the stroke adjustment motor is fully open.**
- **The permanent display shows to what degree the motor has opened in % (the greater the percentage, the more open the servomotor.)**

Complete Operating Menu / Description

Control

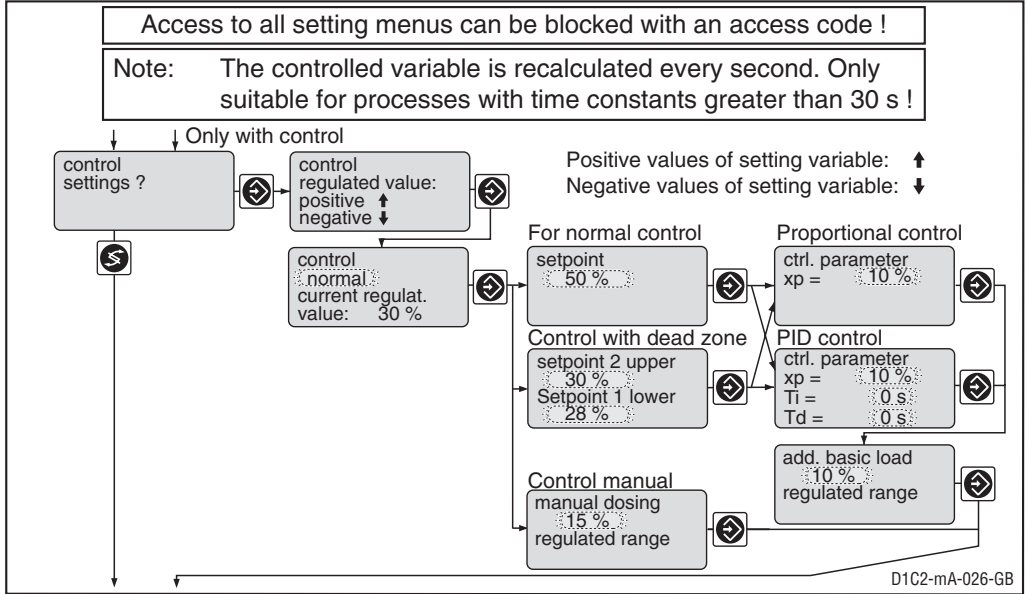

	Initial value	Possible values			Remarks
		Increment	Lower value	Upper value	
Control	normal	normal with dead zone manual			When controlling with dead zone, the feed forward control is not used for measured values within the dead zone.
Setpoint	50 % 10.00 mA	0.1 % 0.01 mA	-5.0 % -1.00 mA	105 % 21 mA	Measuring unit: % Measuring unit: mA 2 setpoints necessary for control with dead zone. Setpoint 1 ≤ setpoint 2 xp referred to measuring range
Control parameter xp	10 %	1 %	1 %	500 %	
Control parameter Ti	off	1 s	1 s	9999 s	Function off = 0 s
Control parameter Td	off	1 s	1 s	2500 s	Function off = 0 s
Additional load	0 %	1 %	-100 %	+100 %	
Manual metering	0 %	1 %	-100 %	+100 %	

Abbreviation for control variables:

x_p = 100 %/Kp (inverse proportional coefficient)

T_i = I controller integration time [s]

T_d = D controller differential time [s]

Complete Operating Menu / Description

Feed forward control

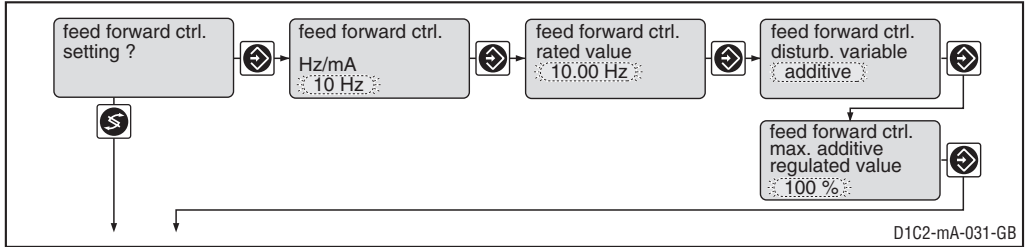

	Initial value	Possible values			Remarks
		Increment	Lower value	Upper value	
Feed forward control (Flow)	as per identity code	None 10 Hz 500 Hz			Signal processing: Signal <0.02 Hz = No flow Signal <0.2 Hz = No flow Signal <0.2 mA = No flow Signal <4.2 mA = No flow
	Standard signal 4–20 mA	0...20 mA 4...20 mA			
Feed forward control rated value	10 Hz 500 Hz 20 mA	0.01 Hz 1 Hz 0.1 mA	0.1 Hz 5 Hz 0.4 mA	10 Hz 500 Hz 20 mA	Depended on signal type. Maximum limitation of range used.
Feed forward control feed forward control effect	multiplicative	multiplicative additive			
Feed forward control additive regulated value	100 %	1 %	-500%	+500%	

Standard signal output 1

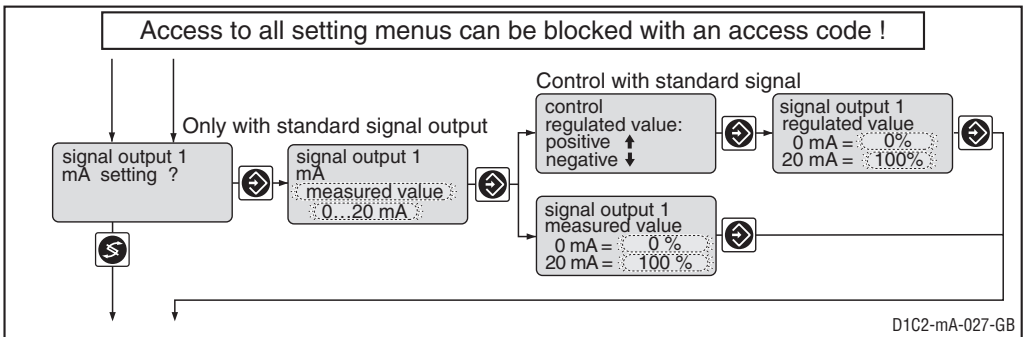

Complete Operating Menu / Description

Standard signal output 2

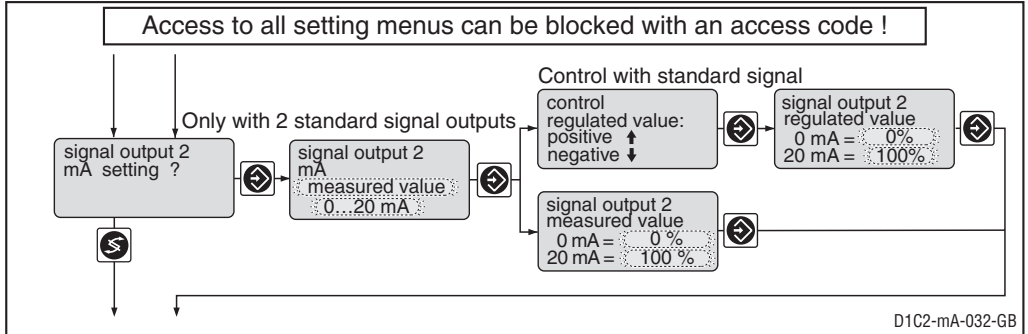

	Initial value	Possible values			Remarks
		Increment	Lower value	Upper value	
Variable allocation	as per identity code	Measured value			If control applicable
Output range	0...20 mA	Controlled variable 0...20 mA 4...20 mA 3.6/4-20 mA			
Range measured value	0-100 % 0-20.00 mA	0,1 % 0,01 mA	-5 % -1,00 mA	105 % 21,00 mA	Reduction to 3.6 mA when alarm relay switches (not limit value violation)
Range controlled variable	0 %...+100 %	1 %	-100 %	+100 %	Minimum range 1 % of measured value Minimum range 1 %

General setting

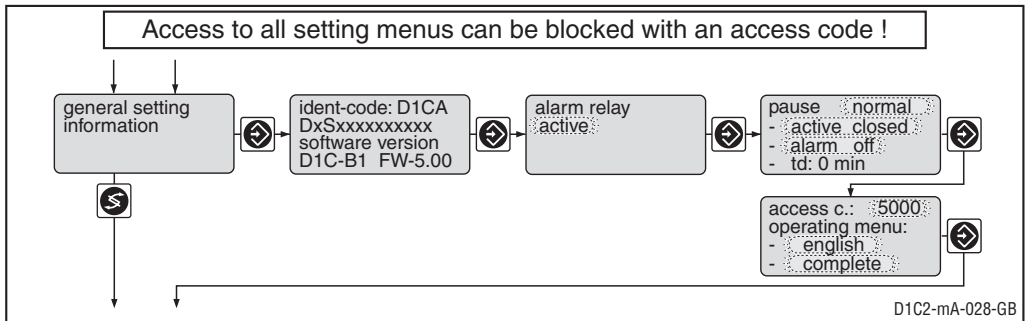

Complete Operating Menu / Description

	Initial value	Possible values		Upper value	Remarks
		Increment	Lower value		
Alarm relay	active	active not active			Reacts as a make contact Reacts as a break contact Alarm relay can be triggered by pause contact
Pause	normal	normal hold			
Control input pause	active closed	active closed active open			
Alarm pause	off	off on			
td	0 min	1 min	0 min	60 min	
Access code	5000	1	1	9999	
Language	as per identity code	as per identity code			
Operating menu	complete	restricted complete			

Normal pause

If the pause switch is off, the DULCOMETER® D1C sets the operating outputs to “0” for as long as the pause switch is off or for a set time delay t_d (if t_d is set to > 0 min). While the pause switch is off, the D1C establishes the P-proportion in the background.

With PID-control (identity code characteristics “control characteristic” = 2): the I-proportion is stored when the pause is switched off (I-proportion then usually only present if $T_i > 0$ has been selected in the “Control setting?” setting menu).

Exception: the standard signal outputs mA for the measured value or correction value are not affected by the pause.

After pause is activated, the operating outputs remain at “0” for the length of the time delay t_d . The time delay t_d must be set up in such a way that in this time e.g. sample water (process-specific current concentration) flows to the sensor.

With PID-control (identity code characteristics “control characteristic” = 2): The control variable output resulting from the pause and the expiry of the time delay t_d is reconciled jointly with the current P-component and (if T_i is set > 0) with the stored I-component.

Pause hold

If the pause switch is off, the DULCOMETER® D1C freezes the operating output at the most recent value for as long as the pause switch is off or for a set time delay t_d (if t_d is set to > 0 min). Whilst the pause switch is off, the D1C establishes the P-proportion in the background.

With PID-control (identity code characteristics “control characteristic” = 2):

Even the mA standard signal outputs for measured value or correction value are frozen.

After pause is activated, the operating outputs remain frozen for the length of the time delay t_d . The time delay t_d must be set up in such a way that in this time e.g. sample water (process-specific current concentration) flows to the sensor.

With PID-control (identity code characteristics “control characteristic” = 2): The control variable output resulting from the pause and the expiry of the time delay t_d is reconciled jointly with the current P-proportion and (if T_i is set > 0) with the newly established I-proportion.

9 Faults / Notes / Troubleshooting

Fault	Fault text	Symbol	Effect on metering	Effect on control	Alarm with acknowledgement	Remarks	Remedy
Measured value Checkout time measured value exceeded	<i>Check probe</i>	⊖	Basic load	Stop	Yes	Function detachable	Check function of sensor, exceed checkout time
Signal exceeded/drops below value	<i>input 3 mA input > 23 mA</i>	⊖	Basic load	Stop	Yes	Signal <3.0 ±0.2 mA or >23 ±0.2 mA	Check sensor, transducer and cable connection
Feed forward control Signal drops below value	<i>feedfwd input <4 mA</i>	⊖	stops continue	continue	Yes	Signal < 3.8 ±0.2 mA or >23 ±0.2 mA Value last valid is used	Check sensor, transducer and cable connection
Signal exceeded	<i>feedfwd input >23 mA</i>	⊖	continue	continue	Yes	Function detachable	Define cause, reset values if necessary
Limit transgression after checkout time limits Control "on" Control "off"	<i>Limit 1 Limit 2</i> ↕↕	⊖	Stop or Basic load	Stop	Yes		
Servomotor Position not reached	<i>Servomot. defect</i>	⊖			Yes	Servomotor closes	Check servomotor
Electronics error	<i>System defect</i>	⊖	Stop	Stop	Yes	Electronic data defective	Call in service

Operation	Note text	Symbol	Effect		Alarm with acknowledgement	Remarks	Remedy
			on metering	on control			
Pause contact	<i>Pause</i>	⊖	Stop	Stop	No/Yes*	No further fault check	-
	<i>Pause/hold</i>			PI-part frozen			
Stop button	<i>Stop</i>	⊖	Stop	Stop	No	Relay drops out	-
During servomotor setting Position feed back wrong Upper position <40 % max. value Lower position >30 % range	<i>Direction check Final value too small Final value too big</i>					Without correct adjustment the last valid values are still used	Check connection of relay, potentiometer Adjust the operation region of the servomotor correctly

*depending on whether "Alarm on" or "Alarm off" set in "General settings"