

Operating Instructions

DULCOMETER® D1C

Part 2: Adjustment and Operation,
Measured Variable Redox/ORP

D1C2-001-D



Type D

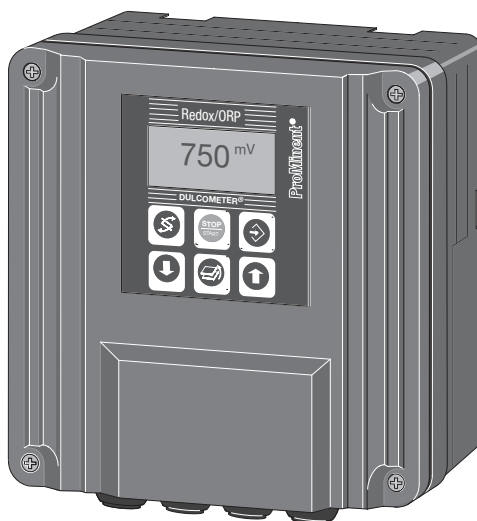

Type W

D1C A _____

Please enter the identity code of your device here.

**Please completely read through operating instructions! · Do not discard!
The warranty shall be invalidated by damage caused by operating errors!**

2 Contents / General User Information

	Page
1 Device Identification / Identity Code	2
2 General User Information	3
3 Device Overview / Controls	4
4 Functional Description	5
5 Display Symbols	6
6 Operation	7
7 Restricted Operating Menu	8
Layout	8
Description	9
8 Complete Operating Menu	12
Overview	12
Description	13
9 Fault / Remarks / Troubleshooting	23

General User Information

These operating instructions describe the technical data and function of the series DULCOMETER® D1C controller, provide detailed safety information and are divided into clear steps.



IMPORTANT

- ***Please observe the parts of these operating instructions applicable to your particular version! This is indicated in the Section “Device Identification / Identity Code”.***
- ***Correct measuring and dosing is only possible in the case of impeccable operation of the probe. The probe has to be calibrated / checked regularly!***

3 Device Overview / Controls

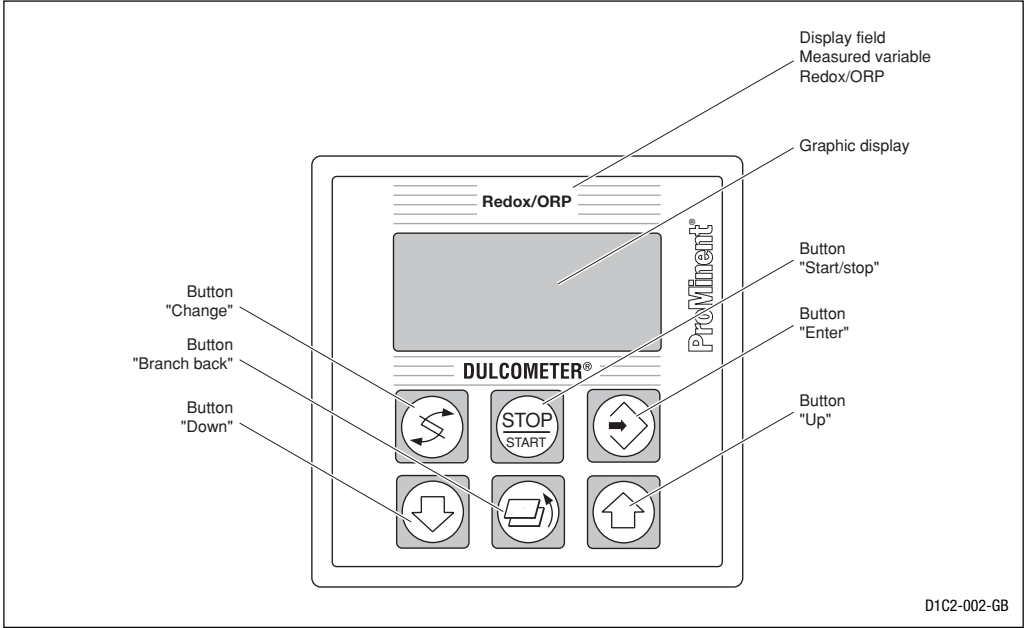

	<p>CHANGE button</p> <p>To change over within a menu level and to change from one variable to another within a menu point.</p>
	<p>START/STOP button</p> <p>Start/stop of control and metering function.</p>
	<p>ENTER button</p> <p>To accept, confirm or save a displayed value or status. For alarm acknowledgement.</p>

	<p>UP button</p> <p>To increase a displayed numerical value and to change variables (flashing display)</p>
	<p>BRANCH BACK button</p> <p>Back to permanent display or to start of relevant setting menu.</p>
	<p>DOWN button</p> <p>To decrease a displayed numerical value and to change variables (flashing display).</p>

4 Functional Description

NOTE

Please refer to the description of the complete operating menu in Section 8 for a detailed description of the individual characteristics of the DULCOMETER® D1C controller!

4.1 Operating Menu

The D1C controller permits settings to be made in two different menus. All values are preset and can be changed in the complete operating menu.

The controller is delivered with a restricted operating menu so that the D1C controller can be used effectively in many applications from the very onset. If adaptations prove to be necessary, all relevant parameters can then be accessed by switching over to the complete operating menu.

4.2 Access Code

Access to the setting menu can be prevented by setting up an access code. The D1C controller is supplied with the access code 5000 which permits free access to the setting menu. The calibration menu remains freely accessible even when access to the setting menu is blocked by the code.

4.3 Control

The D1C can operate as a proportional controller or as a PID controller - dependent on the device version (see identity code) and the setting.

The controlled variable is recalculated once a second. Control procedures which require rapid correction of setpoint deviations (less than approx. 30 seconds) cannot be processed with this controller. The cycle times must be taken into consideration when activating solenoid valves (pulse length) in the same way as their running times when activating servomotors (3-point).

Via the control input pause, the control function (selection of controlled variable) can be switched off. The calculation of the controlled variable starts again after cessation of "pause".

4.4 Feed Forward Control

The D1C controller can process a signal of a feed forward control. Depending on the device version (see identity code) and the setting, this signal can be obtained in any form of a 0–20 mA or 4–20 mA signal or as a digital contact signal with the maximum frequencies 10 Hz or 500 Hz.

During start-up, the zero point has to be checked. The feed forward control is not designed for switching off permanently the actuating variable (signal \approx 0).

This signal can be used, for example, for flow-proportional metering (multiplicative effect) or feed forward-dependent basic load metering (additive effect). The result of control variable calculation from the proportional or PID control is multiplied by or added to the feed forward signal. A multiplicative feed forward variable at the level of the set rated value carries over the calculated control variable unchanged into the controlled variable:

$$\text{Controlled variable} = \text{Feed forward variable}/\text{rated value} \times \text{calculated control variable}$$

An additive feed forward variable at the level of the rated value results in maximum controlled variable:























$$\text{Controlled variable (max. 100 \%)} = \text{Feed forward variable}/\text{rated value} \times \text{max. controlled variable} + \text{calculated control variable}$$

4.5 Error Messages

Error messages and information are indicated on the bottom line in the permanent display 1. Errors to be acknowledged (acknowledgement switches off the alarm relay) are indicated by the "E". Errors/notes which still apply after acknowledgement are indicated alternately. During correction variable processing (temperature for correction of pH-value), the value is indicated in the same line as the error/note. Faults which are rectified of their own accord due to changed operating situations are removed from the permanent display without the need for acknowledgement.

5 Display Symbols

The display of the DULCOMETER® D1C controller uses the following symbols:

Description	Comment	Symbol
Limit value transgression Relay 1, upper	Symbol left	
Relay 1, lower	Symbol left	
Relay 2, upper	Symbol right	
Relay 2, lower	Symbol right	
Metering pump 1 (oxidant) Control OFF	Symbol left	
Control ON	Symbol left	
Metering pump 2 (reducing agent) Control OFF	Symbol right	
Control ON	Symbol right	
Solenoid valve 1 (oxidant) Control OFF	Symbol left	
Control ON	Symbol left	
Solenoid valve 2 (reducing agent) Control OFF	Symbol right	
Control ON	Symbol right	
Servomotor Control, open relay		 
Control, close relay		 
Without control		 
Position feedback	Thickness of bar increases from left to right during opening	
Stop button pressed		
Manual metering		
Fault		

7 Restricted Operating Menu / Layout

The restricted operating menu permits simple operation of the most important parameters. The following overview shows the settings which can be selected.

Number and scope of setting menus is dependent on the device. Access to setting menus can be blocked with access code.

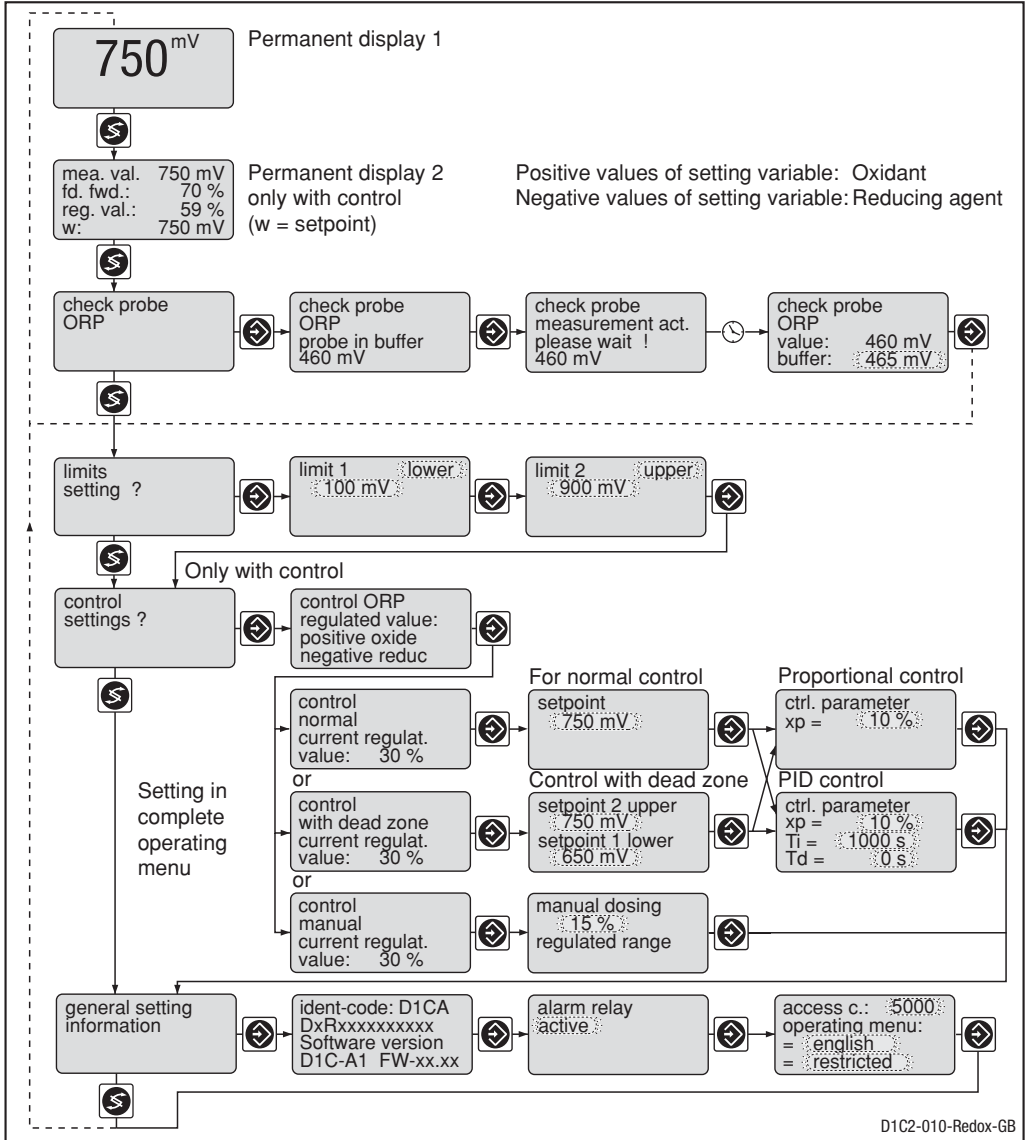

Restricted Operating Menu / Description

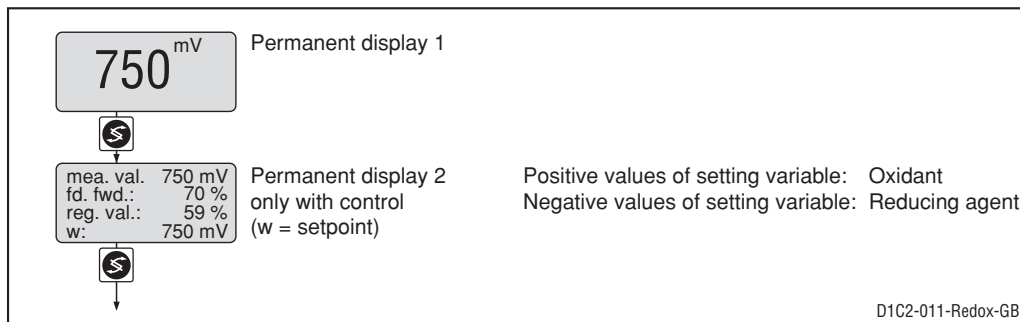

Checking the Redox Probe

During checking, metering is reduced to the set basic capacity. The standard signal of the output (measured value) is reduced to 0 mA or 4 mA. The measured value or the standard buffer value 220 mV or 465 mV is proposed as the buffer value; this value is adjustable (arrow keys). After everything has been checked, all error tests which refer to the measured value are restarted.

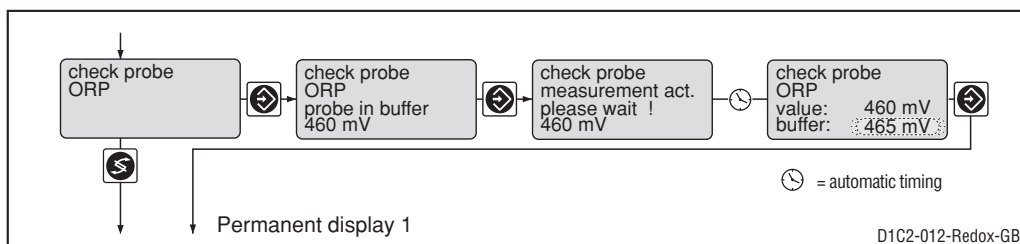

	Initial value	Possible values		
		Increment	Lower value	Upper value
Buffer values 185–265 mV 425–505 mV	Measured valve 220 mV 465 mV	1 mV	-2000 mV	+2000 mV

Error message	Condition	Effect
Measured value high	Measured value 40 mV > buffer	Return to permanent display: Basic metering load "
Measured value low	Measured value 40 mV < buffer	

Restricted Operating Menu / Description

Limits

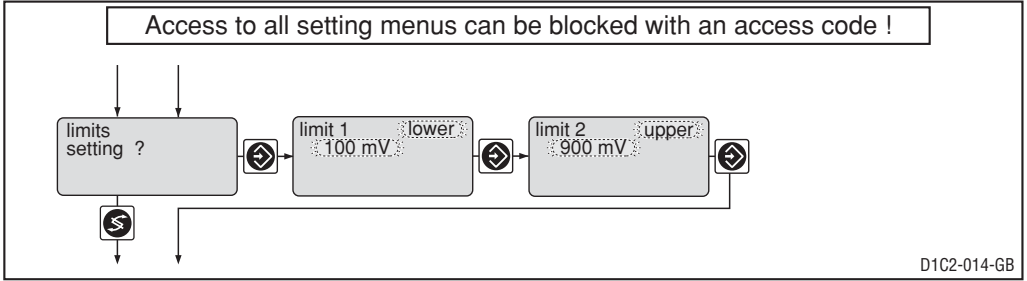

	Initial value	Possible values			Remarks
		Increment	Lower value	Upper value	
Type of limit transgression	Limit 1: lower Limit 2: upper	upper lower off *)			Limit transgression when exceeding or dropping below value *) only with limit relay
Limit value	Limit 1: 500 mV Limit 2: 1000 mV	1 mV 1 mV	-2000 mV -2000 mV	2000 mV 2000 mV	

Control

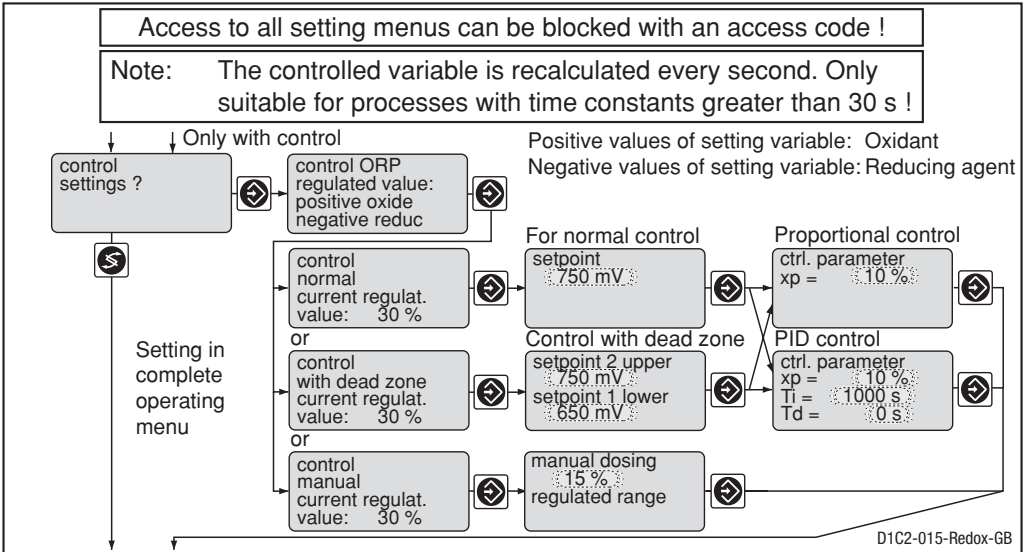

Restricted Operating Menu / Description

	Initial value	Possible values			Remarks
		Increment	Lower value	Upper value	
Setpoint	750 mV	1 mV	lower limit measuring range	upper limit measuring range	2 setpoints necessary for control with dead zone. Setpoint 2 > setpoint 1
Control parameter xp	10 %	1 %	1 %	500 %	xp referred to measuring range
Control parameter Ti	off	1 s	1 s	9999 s	Function off = 0 s
Control parameter Td	off	1 s	1 s	2500 s	Function off = 0 s
Manual metering	0 %	1 %	-100 %	+100 %	

General Settings

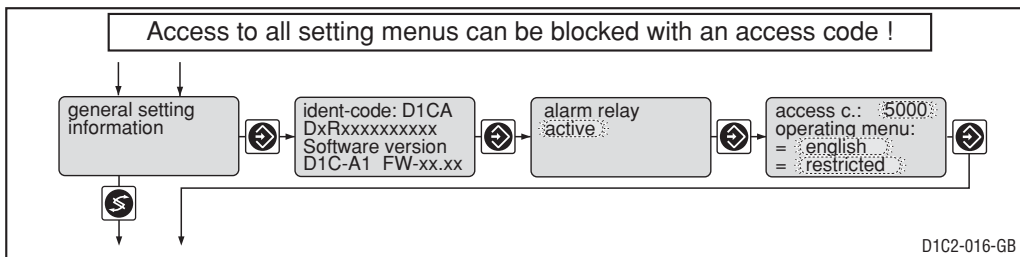

	Initial value	Possible values			Remarks
		Increment	Lower value	Upper value	
Alarm relay	active	active not active			
Access code	5000	1	1	9999	
Language	as per identity code	as per identity code			
Operating menu	restricted	restricted complete			

8 Complete Operating Menu / Overview

All parameters of the controller can be set in the complete operating menu (access see previous page). The following overview shows the settings which can be selected:

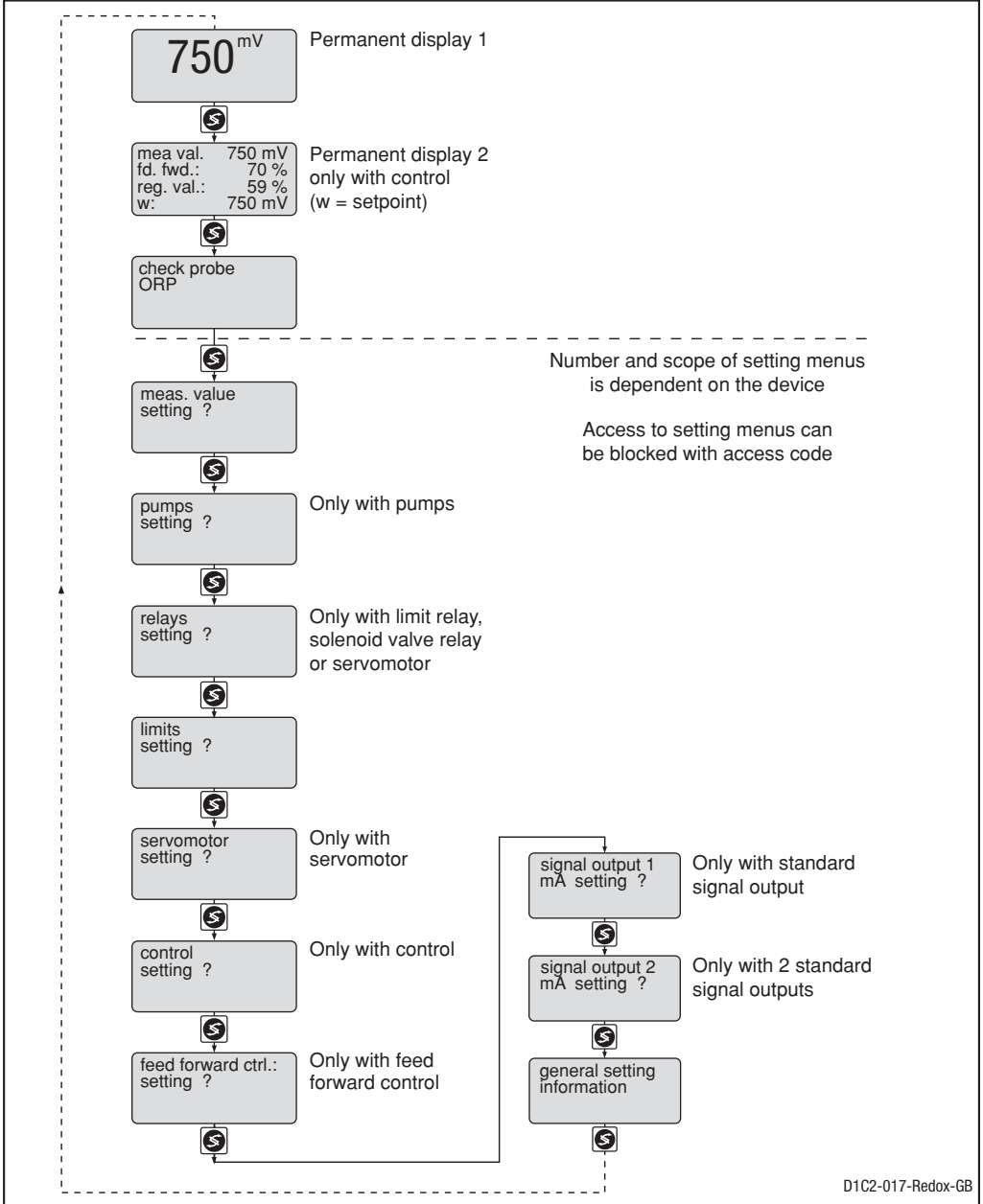

Complete Operating Menu / Description

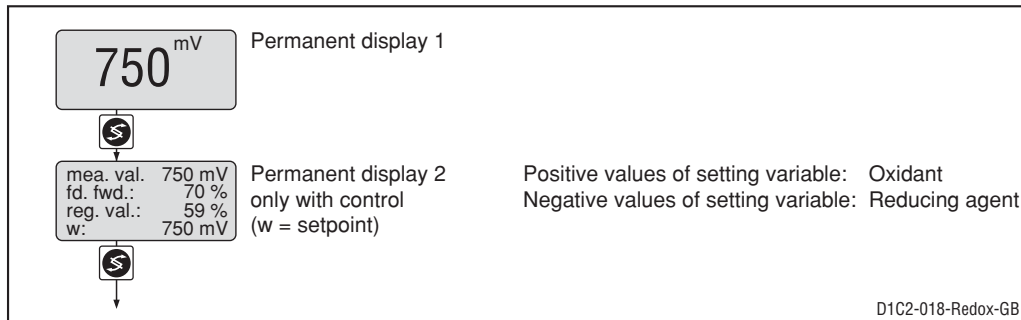

Checking the Redox Probe

During checking, metering is reduced to the set basic capacity. The standard signal of the output (measured value) is reduced to 0 mA or 4 mA. The measured value or the standard buffer value 220 mV or 465 mV is proposed as the buffer value; this value is adjustable (arrow keys). After everything has been checked, all error tests which refer to the measured value are restarted.

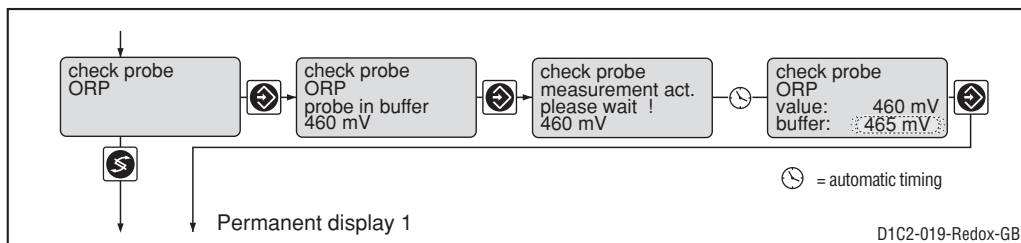

	Initial value	Possible values			Identification code expression
		Increment	Lower value	Upper value	
Buffer values 185–265 mV	Measured value 220 mV	1 mV	-2000 mV	+2000 mV	when measured variables 2 and 5 are connected
425–505 mV	465 mV		–	+1000 mV	when measured variable 1 is connected

Error message	Condition	Effect
Measured value high	Measured value 40 mV > buffer	Return to permanent display: Basic metering load "
Measured value low	Measured value 40 mV < buffer	

Complete Operating Menu / Description

Measured Value

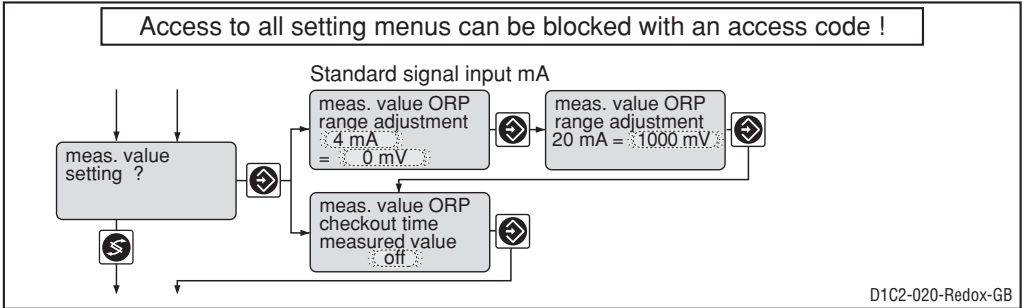

ATTENTION
 When changing the range adjustment, the adjustments in all menus have to be checked!

	Initial value	Possible values			Remarks
		Increment	Lower value	Upper value	
Standard signal input lower signal limit	4 mA	0 mA 4 mA			
Allocated Special voltage	0-1 V	1 mV	-2000 mV	+2000 mV	
Checkout time	off	1 s	1 s	9999 s	Constant measurement signal results in message and alarm. Function off = 0 s

Pumps

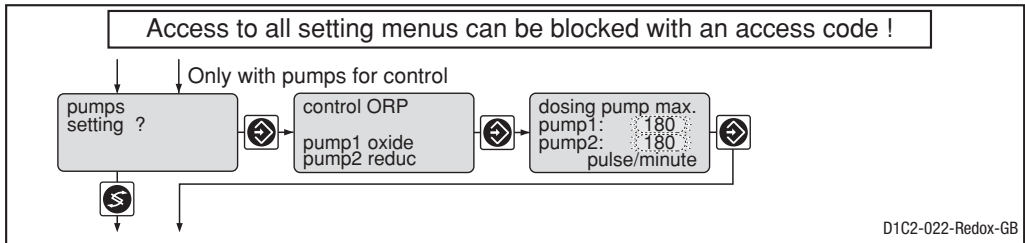

	Initial value	Possible values			Remarks
		Increment	Lower value	Upper value	
Max. stroke/minute of pumps 1 and 2	180	1	1	500	off = 0 strokes/min

Complete Operating Menu / Description

Relay for power control

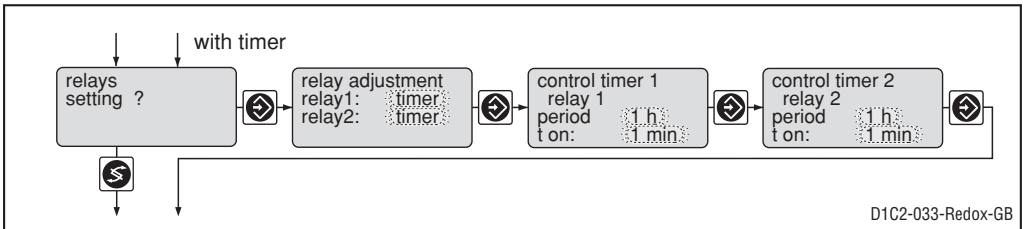
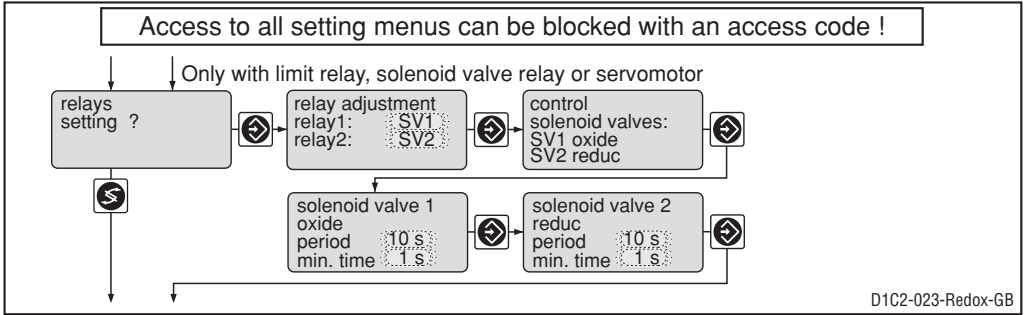

	Initial value	Possible values		Upper value	Remarks
		Increment	Lower value		
Relay adjustment	as per identity code	Solenoid valve (SV1, SV2)* Limit value (LV1, LV2)** Actuator 1,2* off			* The relays are activated in the event of failure and in pause or stop modes **The relays also remain in failure mode while pause and stop modes are active
Period	10 s	1 s	10 s	9999 s	
min. time	1 s	1 s	1 s	period/2	

Complete Operating Menu / Description

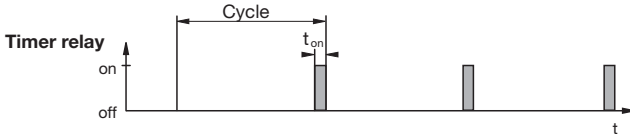

IMPORTANT

The timer will be reset if there is a drop in the power supply.

At the end of the (timer) cycle time the DULCOMETER® D1C closes the assigned relay for the duration of “t on” (timer). “Pause” interrupts the timer.

When the clock is shown in the LC display the timer can be reset to the start of the cycle at precisely this point using the enter button.

The % figure in the LC display indicates the progress of the current cycle.

Timer relays may be used, e.g. for shock metering or sensor cleaning.

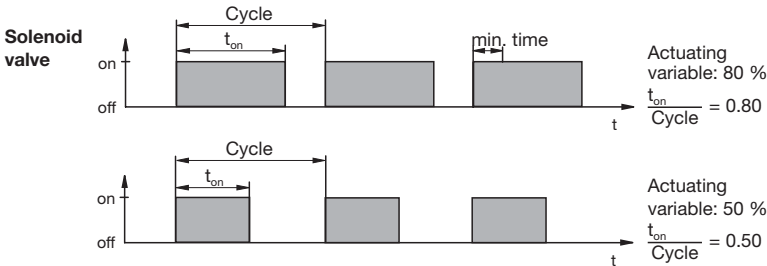

The switching time of the DULCOMETER® D1C (solenoid valve) depends on the actuating variable and the “min. time” (smallest permitted operating factor of the connected device).

The actuating variable determines the ratio $t_{on}/cycle$ and thus the switching times (see fig. above).

The “min. time” influences the switching times in two situations:

a) theoretical switching time < min. time:

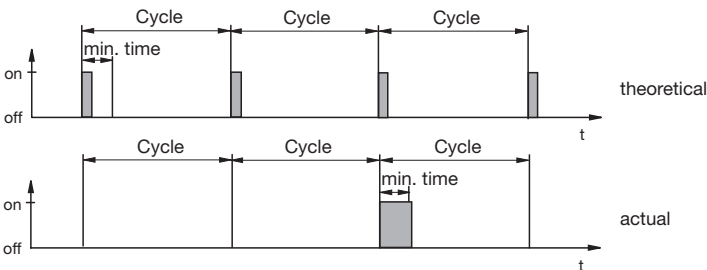

The DULCOMETER® D1C does not switch for a certain number of cycles until the sum of the theoretical switching times exceeds the “min. time”. Then the DULCOMETER® D1C switches for the duration of this total time.

Complete Operating Menu / Description

b) theoretical switching time > (cycle - min. time) and calculated switching time < cycle

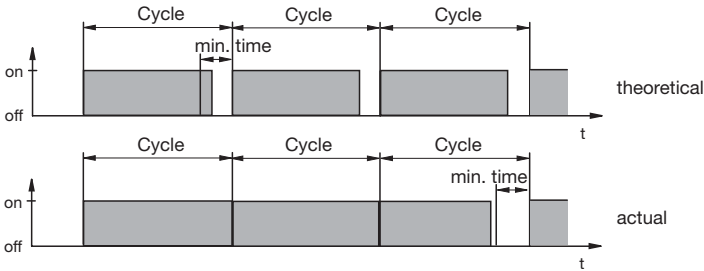

The DULCOMETER® D1C does not deactivate for a certain number of cycles until the differences between cycle and theoretical switching time exceed the “min. time”.

Limits

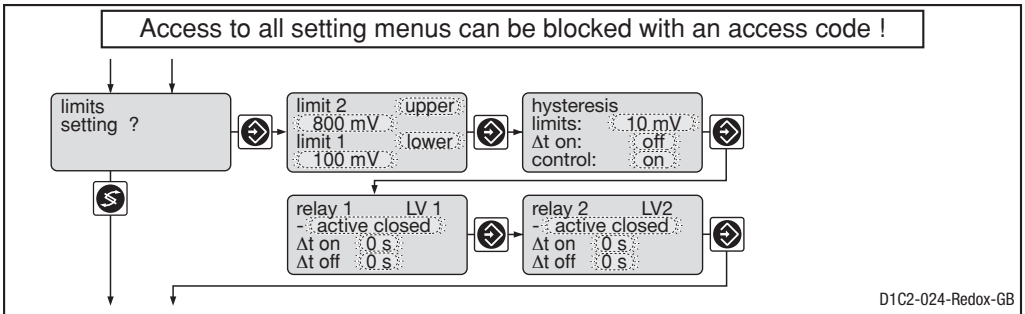

	Initial value	Possible values			Remarks	
		Increment	Lower value	Upper value		
Type of limit transgression		upper lower off*)			Limit transgression when exceeding or dropping below valve *) only with limit relay	
Limit 1: Limit 2:	lower upper					
Limit value	Limit 1: Limit 2:	500 mV 1000 mV	1 mV 1 mV	-2000 mV -2000 mV	2000 mV 2000 mV	
Switch-on delay Δt on	0 s	1 s	0 s		9999 s	
Switch-off delay Δt off	0 s	1 s	0 s		9999 s	
Hysteresis limits	10 mV	1 mV	10 mV		2000 mV	Effective in direction of cancelling limit transgression
Checkout time limits	off	1 s	1 s		9999 s	Results in message and alarm. off = 0 s: Function switched off, no message, no alarm

Complete Operating Menu / Description

Servomotor

Activation of the servomotor must be carried out with the same meticulous care as taken when calibrating a measuring probe. The **operating range** is defined by the total resistance range of the feedback potentiometer. The maximum limit of the range actually used is set by defining the **control range**.

- CAUTION**
- To ensure correct operation, the activation time of the actuator used should not be less than 25 seconds for the control range from 0...100 %!
 - Activation of the servomotor must be carried out with the same meticulous care as taken when calibrating a measuring probe.

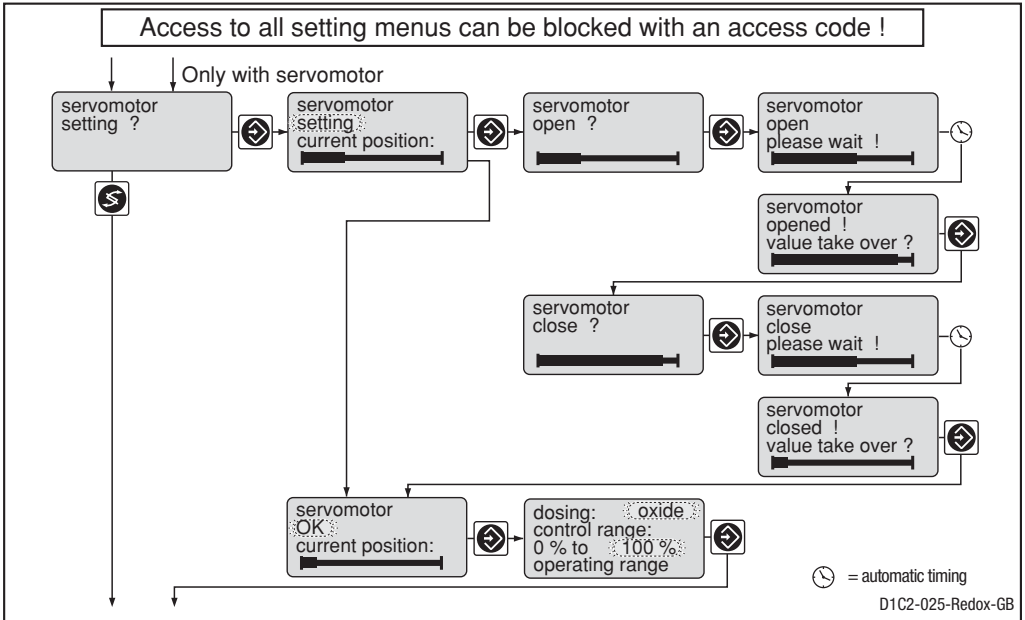

	Initial value	Possible value		Upper value	Remarks
		Increment	Lower value		
Servomotor	Setting	Setting OK off			
Control direction	Oxidant	Oxidant Reducing agent			
Control range	100 %	1 %	10 %	100 %	in % of operating range

Complete Operating Menu / Description

NOTE

- If the broad bar is to the far right, the servomotor is fully open.
- The continuous display shows the degree (in %) to which it is open (the greater percentage, the more open the servomotor).

Control

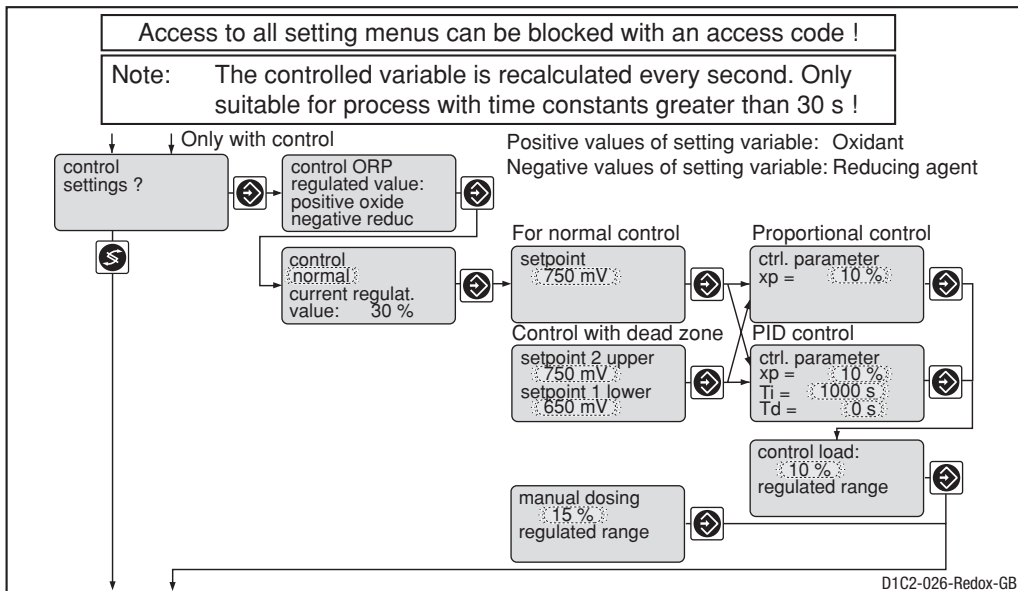

	Initial value	Possible values			Remarks
		Increment	Lower value	Upper value	
Control	normal	normal with dead zone manual			When controlling with dead zone, the feed forward control is not used for measured values within the dead zone. 2 setpoints necessary for control with dead zone. Setpoint 2 > setpoint 1
Setpoint	750 mV	1 mV	Lower limit measuring range	Upper limit measuring range	xp referred to measuring range
Control parameter xp	10 %	1 %	1 %	500 %	Function off= 0 s
Control parameter Ti	off	1 s	1 s	9999 s	Function off= 0 s
Control parameter Td	off	1 s	1 s	2500 s	Function off= 0 s
Additive basic load	0 %	1 %	-100 %	+100 %	
Manual metering	0 %	1 %	-100 %	+100 %	

Abbreviations for control variables:

x_p : 100 %/Kp (inverse proportional coefficient)

T_i : Integration time of I-controller [s]

T_d : Differential time of D-controller [s]

Complete Operating Menu / Description

Feed forward control

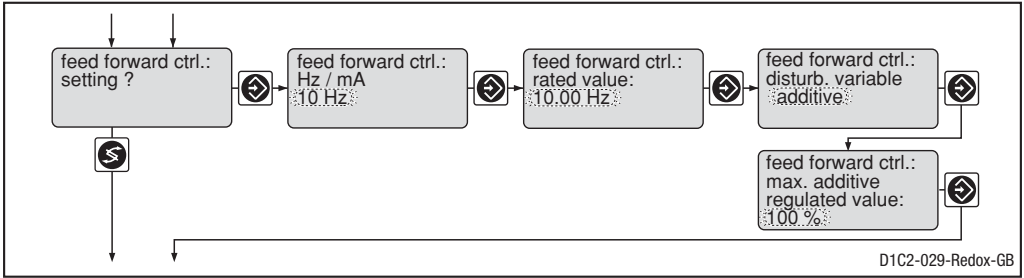

	Initial value	Possible values			Remarks
		Increment	Lower value	Upper value	
Feed forward control (Flow)	as per identity code	None 10 Hz 500 Hz			Signal processing: Signal <0.02 Hz = no flow Signal <0.2 Hz = no flow Signal <0.2 mA = no flow Signal <4.2 mA = no flow
	Standard signal: 4–20 mA	0...20 mA 4...20 mA			
Feed forward control rated value	10 Hz 500 Hz 20 mA	0.01 Hz 1 Hz 0.1 mA	0.1 Hz 5 Hz 0/4 mA	10 Hz 500 Hz 20 mA	Depended on signal type. Maximum limitation of range used.
Feed forward control	multiplicative	multiplicative			
Feed forward control effect		additive			
Max. add. regulated value	100 %	1 %	-500 %	+500 %	only with add. feed forward control

Standard Signal Output 1

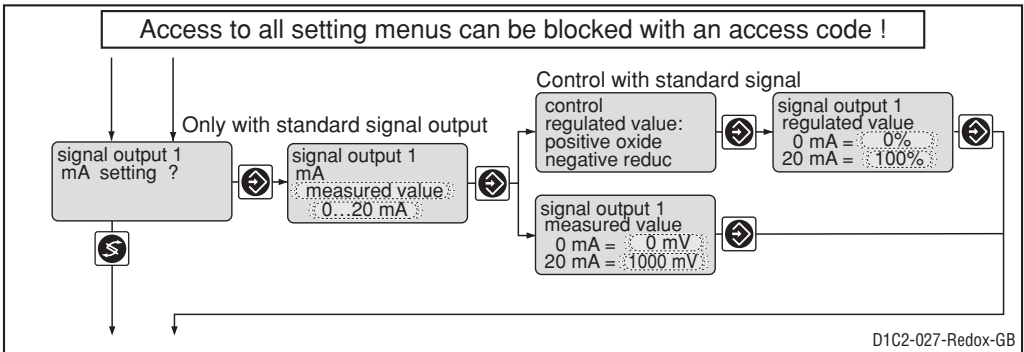

Complete Operating Menu / Description

Standard Signal Output 2

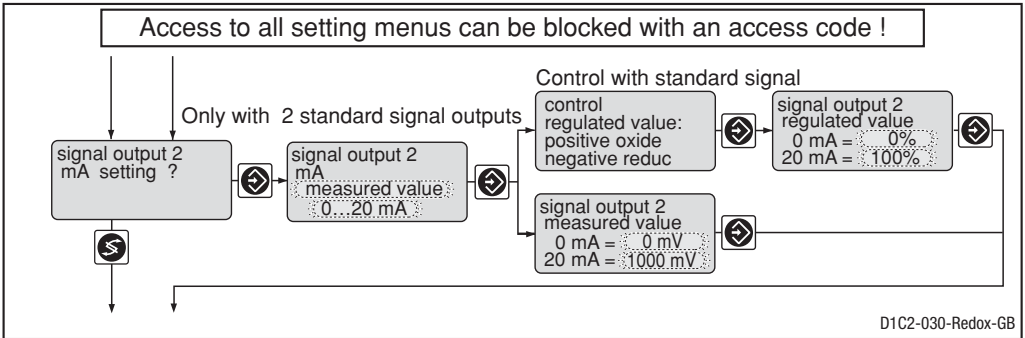

	Initial value	Possible values			Remarks
		Increment	Lower value	Upper value	
Variable allocation	as per identity code	Measured value Controlled variable			If control applicable
Output range	0...20 mA	0...20 mA 4...20 mA			
Range measured value	0-1 V	1 mV	-2000 mV	2000 mV	Minimum range 10 mV
Range controlled variable	0%...+100 %	1 %	-100 %	+100 %	Minimum range 1 %

General setting

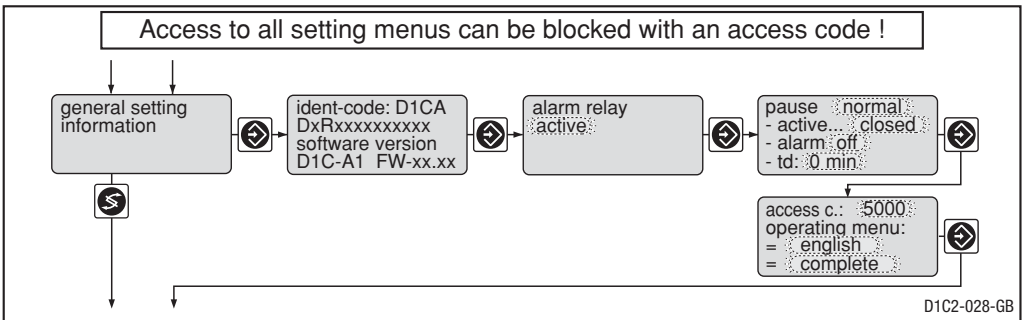

Complete Operating Menu / Description

	Initial value	Possible values		Remarks
		Increment	Lower value	
Alarm relay	active	active not active		
Pause	normal	normal Hold		
Control input pause	closed	closed open		
Pause with alarm	off	off on		
td	0 min	1 min	0 min	60 min
Access code	5000	1	1	9999
Language	as per identity code	as per identity code		
Operating menu	complete	restricted complete		

Standard Pause

If the pause-switch is off, the DULCOMETER® D1C sets the operating outputs to “0” for as long as the pause-switch is off or for a set time-delay t_d (if t_d is set to > 0 min). Whilst the pause-switch is off, the D1C establishes the P-proportion in the background.

With PID-control (Identity code characteristics “control characteristic” = 2): the I-proportion is stored when the pause is switched off (I-proportion then usually only present if $Ti > 0$ has been selected in the “Control setting?” setting menu).

Exception: the standard signal outputs mA for the measured value or correction value are not affected by the pause.

After pause is activated the operating outputs remain at “0” for the length of the time-delay t_d . The time-delay t_d must be set up in such a way that, in this time e.g. sample water (process-specific current concentration) flows to the sensor.

With PID-control (Identity code characteristics “control characteristic” = 2): The control variable output resulting from the pause and the expiry of the time-delay t_d is reconciled jointly with the current P-component and (if Ti is set > 0) with the stored I-component.

Pause Hold

If the pause-switch is off, the DULCOMETER® D1C freezes the operating output at the most recent value for as long as the pause-switch is off or for a set time-delay t_d (if t_d is set to > 0 min). Whilst the pause-switch is off, the D1C establishes the P-proportion in the background.

With PID-control (Identity code characteristics “control characteristic” = 2):

Even the mA standard signal outputs for measured value or correction value are frozen.

After pause is activated the operating outputs remain frozen for the length of the time delay t_d . The time delay t_d must be set up in such a way that, in this time e.g. sample water (process-specific current concentration) flows to the sensor.

With PID-control (Identity code characteristics “control characteristic” = 2): The control variable output resulting from the pause and the expiry of the time-delay t_d is reconciled jointly with the current P-proportion and (if Ti is set > 0) with the newly established I-proportion.

9 Fault / Remarks / Troubleshooting

Fault	Fault text	Symbol	Effect on metering	Effect on control	Alarm with acknowledgement	Remarks	Remedy
Measured value Checkout time	measured value	E	Basic load	Stop	Yes	Function defeatable	Check function of probe
			Signal exceeded/drops below value	Basic load	Stop	Yes	Signal <math>< 3.0 \pm 0.2 \text{ mA}</math> or $> 23 \pm 0.2 \text{ mA}$
Check probe with error	<i>mV calibration faulty</i>	E	Basic load	Stop	No	Metering continues in case of error with unsteady measured values	Check probe, replace if necessary, recalibrate if necessary
Feed forward control	Signal exceeded/drops below value	E			Yes	Signal <math>< 3.0 \pm 0.2 \text{ mA}</math> or $> 23 \pm 0.2 \text{ mA}$ Value last validad is used	Check probe, transducer and cable connection
Limit transgression	after checkout time	E			Yes	Function defeatable	Define cause, reset values if necessary
Servomotor	Position not reached	E			Yes	Servomotor closes	Check servomotor
Electronics error	<i>Servomotor defective</i>	E	Stop	Stop	Yes	Electronic data defective	Call in service
Operation	Note text	Symbol	Effect on metering		Alarm with acknowledgement	Remarks	Remedy
			on metering	on control			
Pause contact	<i>Pause</i>	E	Stop	Stop	No	No further fault check	-
	<i>Pause/Hold</i>				No		
Stop button	<i>Stop</i>	E	Stop	Stop	No	Relay drops out	-
During calibration			Basic load	Stop	No	No error processing of measured variable	-
			Measured 40 mV > buffer	Basic load	Stop	No	
Measured 40 mV < buffer	<i>Measured value low</i>	E					
Probe signal too unsteady	<i>Measured value unsteady</i>						
During servomotor setting	Position feed back wrong					Without correct adjustent the last valid values are still used	Check connection of relay, potentiometer. Adjust the operation region of the servomotor correctly
Upper position < 40 % max. value	<i>Direction check</i>						
Lower position > 30 % range	<i>Final value small</i>						
	<i>Final value big</i>						

