



Operating Instructions

DULCOMETER® D1C

Part 2: Adjustment and Operation,
Measured Variable Conductive Conductivity

D1C2-Leit.-001-GB



Type D

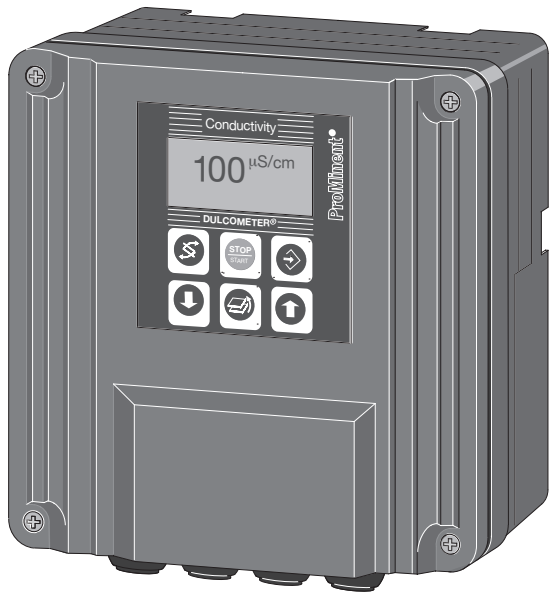

Type W

D1C A _____

Please enter the identity code of your device here!

**Please completely read through the operating instructions! · Do not discard!
The operator shall be liable for any damage caused
by installation or operating errors!**

2 General User Information

	Page
1 Device Identification / Identity Code	2
2 General User Information	3
3 Device Overview / Controls	4
4 Functional Description	5
5 Display Symbols	6
6 Operation diagram	7
7 Restricted Operating Menu	8
Overview	8
Description	9
8 Complete Operating Menu	12
Overview	12
Description	13
9 Fault / Remarks / Troubleshooting	24

General User Information

These operating instructions describe the technical data and function of the series DULCOMETER® D1C controller, provide detailed safety information and are divided into clear steps.



IMPORTANT

- ***Please observe the parts of these operating instructions applicable to your particular version! This is indicated in the Section “Device Identification / Identity Code”!***
- ***Correct measuring and metering is only possible in the case of impeccable operation of the sensor. The sensor has to be calibrated / checked regularly!***

NOTE

A form “Documentation of controller settings type D1C” is available under www.prominent.com/documentation_D1C for the purpose of documenting the controller settings.

3 Device Overview / Controls

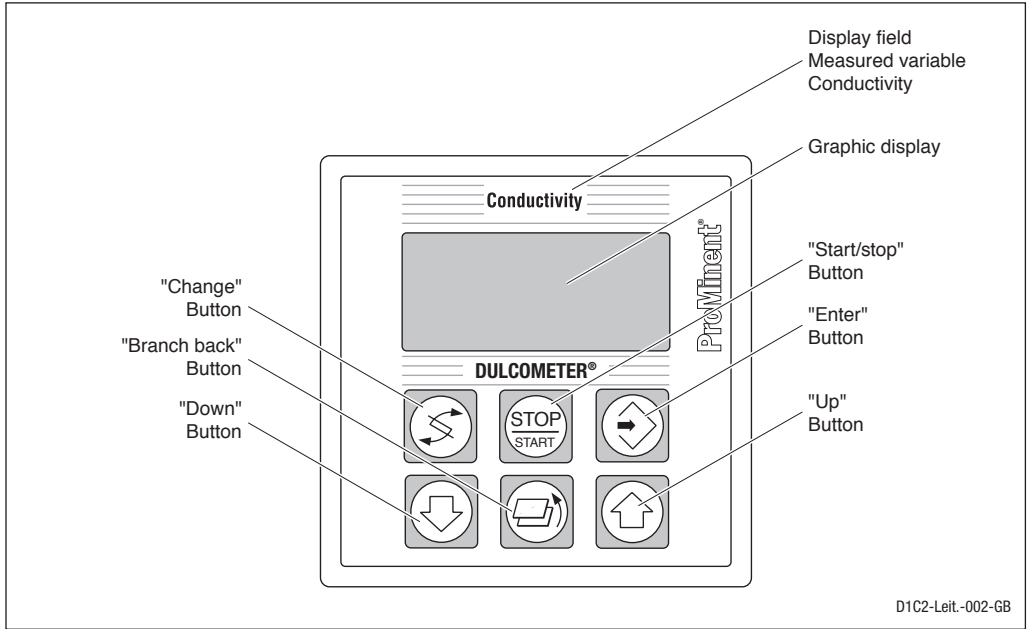

D1C2-Leit.-002-GB

	<p>CHANGE button To change over within a menu level and to change from one variable to another within a menu point.</p>
	<p>START/STOP button Start/stop of control and metering function.</p>
	<p>ENTER button To accept, confirm or save a displayed value or status. For alarm acknowledgement.</p>

	<p>UP button To increase a displayed numerical value and to change variables (flashing display)</p>
	<p>BRANCH BACK button Back to permanent display or to start of relevant setting menu.</p>
	<p>DOWN button To decrease a displayed numerical value and to change variables (flashing display).</p>

4 Functional Description

NOTE

Please refer to the description of the complete operating menu in Section 8 for a detailed description of the individual characteristics of the DULCOMETER® D1C controller!

4.1 Operating Menu

The D1C controller permits settings to be made in two different menus. All values are preset and can be changed in the **complete operating menu**.

The controller is delivered with a **restricted operating menu** so that the D1C controller can be used effectively in many applications from the very onset. If adaptations prove to be necessary, all relevant parameters can then be accessed by switching over to the complete operating menu.

4.2 Access Code

Access to the setting menu can be prevented by setting up an access code. The D1C controller is supplied with the access code 5000 which permits free access to the setting menu. The calibration menu remains freely accessible even if access to the setting menu is blocked by the code.

4.3 Control

The D1C can operate as a proportional controller or as a PID controller - depending on the device version (see identity code) and the setting.

The controlled variable is recalculated once a second. Control procedures which require rapid correction of setpoint deviations (less than approx. 30 seconds) cannot be processed with this controller. The cycle times must be taken into consideration when activating solenoid valves (pulse length) in the same way as their running times when activating servomotors (3-point).

Via the control input pause, the control function (selection of controlled variable) can be switched off. The calculation of the controlled variable starts again after cessation of „pause“.

4.4 Feed Forward Control

The D1C controller can process a signal of a feed forward control. Depending on the device version (see identity code) and the setting, this signal can be obtained in any form of a 0–20 mA or 4–20 mA signal or as a digital contact signal with the maximum frequencies 10 Hz or 500 Hz.

This signal can be used, for example, for flow-proportional metering (multiplicative effect) or feed forward-dependent basic load metering (additive effect). The result of control variable calculation from the proportional or PID control is multiplied by or added to the feed forward signal. A multiplicative feed forward variable at the level of the set rated value carries over the calculated control variable unchanged into the controlled variable:

$$\text{Controlled variable} = \text{Feed forward variable} / \text{rated value} \times \text{calculated control variable}$$

During start-up, the zero point has to be checked. The multiplicative feed forward control is not designed for switching off permanently the actuating variable (signal \approx 0).

An additive feed forward variable at the level of the rated value results in maximum controlled variable:























$$\text{Controlled variable (max. 100 \%)} = \text{Feed forward variable} / \text{rated value} \times \text{max. controlled variable} + \text{calculated control variable}$$

4.5 Error Messages

Error messages and information are indicated on the bottom line in the permanent display 1. Errors to be acknowledged (acknowledgement switches off the alarm relay) are indicated by the symbol „E“. Errors/notes which still apply after acknowledgement are indicated alternately. Faults which are rectified of their own accord due to changed operating situations are removed from the permanent display without the need for acknowledgement.

5 Display Symbols

The display of the DULCOMETER® D1C controller uses the following symbols:

Description	Comment	Symbol
Limit value transgression Relay 1, upper	Symbol left	
Relay 1 lower	Symbol left	
Relay 2 upper	Symbol right	
Relay 2 lower	Symbol right	
Metering pump 1 (Increase conductivity) Control off	Symbol left	
Control on	Symbol left	
Metering pump 2 (Reduce conductivity) Control off	Symbol right	
Control on	Symbol right	
Solenoid valve 1 (Increase conductivity) Control off	Symbol left	
Control on	Symbol left	
Solenoid valve 2 (Reduce conductivity) Control off	Symbol right	
Control on	Symbol right	
Servomotor Control, open relay		 
Control, close relay		 
Without control		 
Position feedback	Thickness of bar increases from left to right during opening	
Stop button pressed		
Manual metering		
Fault		

6 Operation diagram

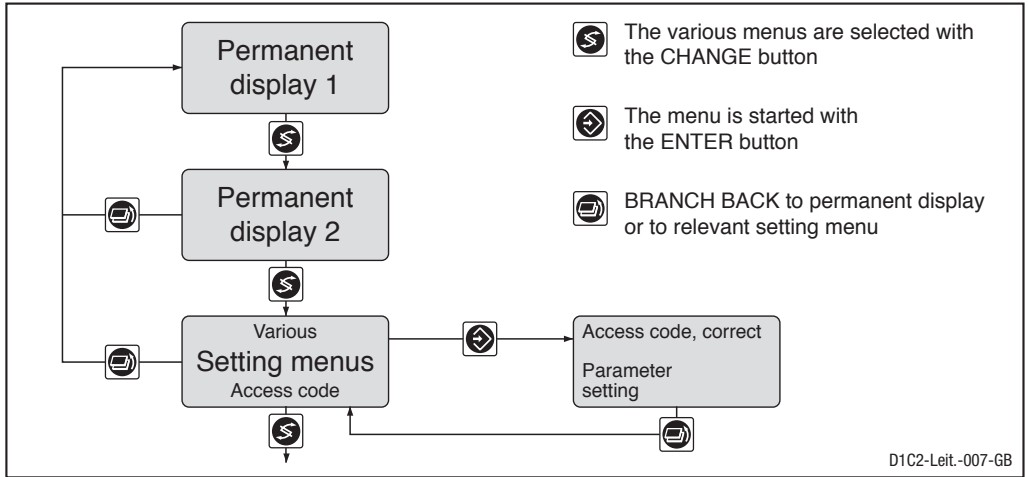

NOTE

Access to the setting menus can be barred with the access code!

The number and scope of setting menus depends on the device version!

If the access code is selected correctly in a setting menu, the following setting menus are also accessible!

If within a period of 10 minutes no button is pushed, the unit automatically branches back from the calibrating menu or a setting menu to the permanent display 1.

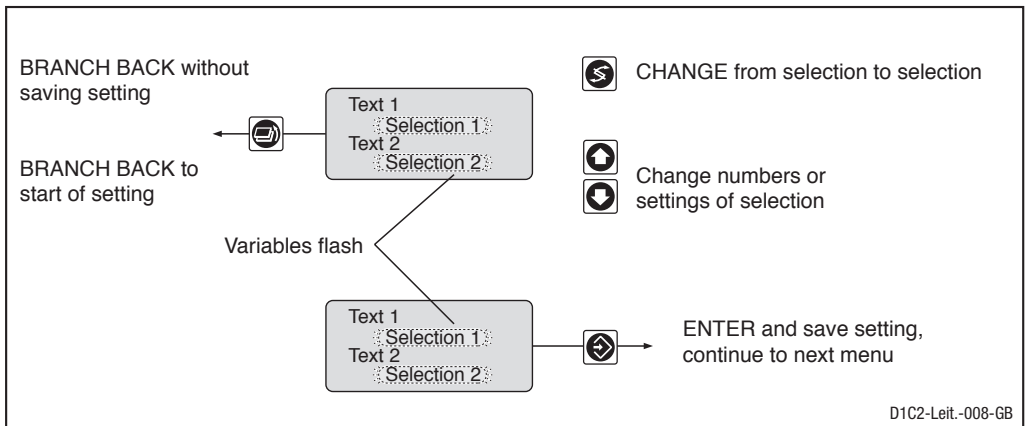

7 Restricted Operating Menu / Overview

The restricted operating menu permits simple operation of the most important parameters. The following overview shows the settings which can be selected:

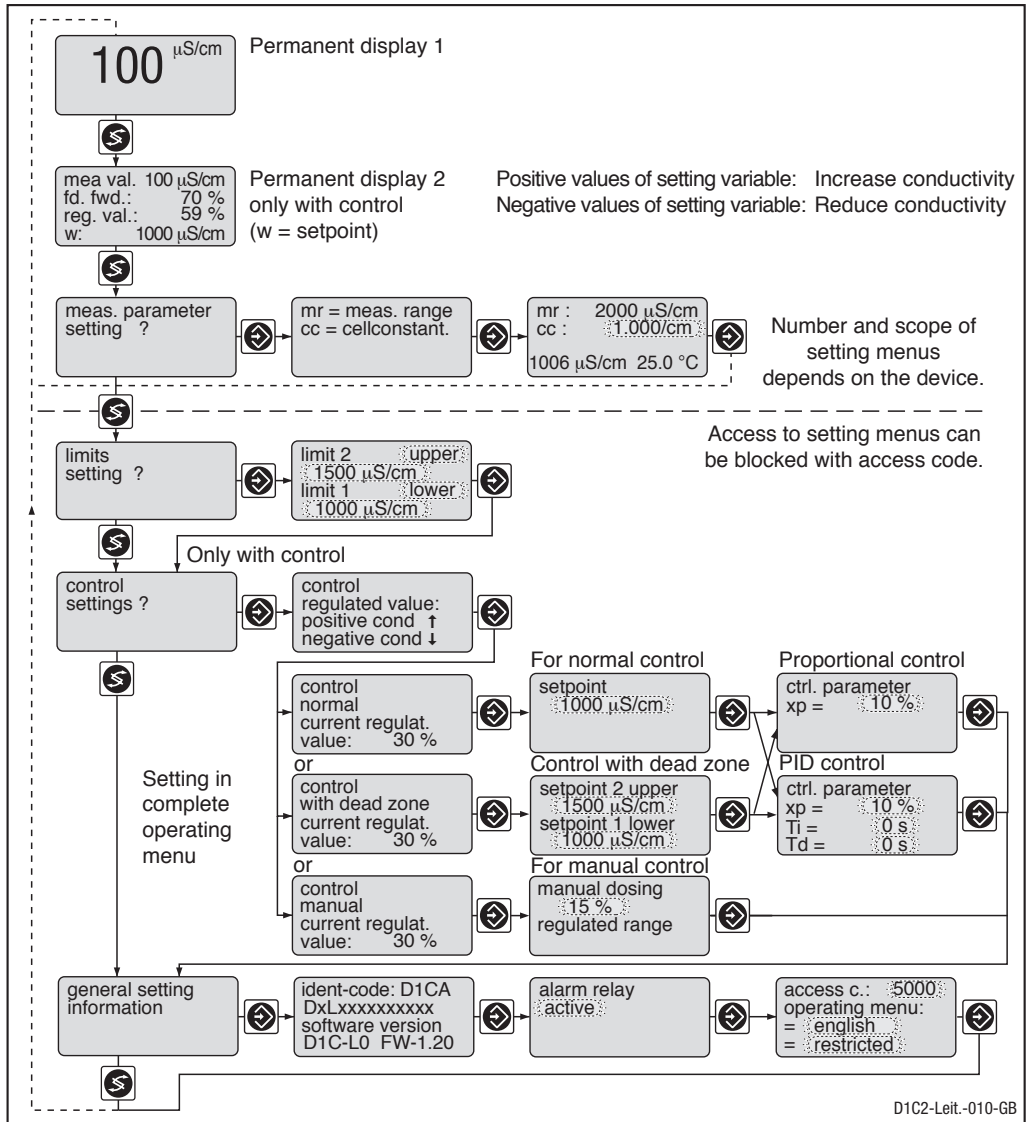

D1C2-Leit.-010-GB

Restricted Operating Menu / Description

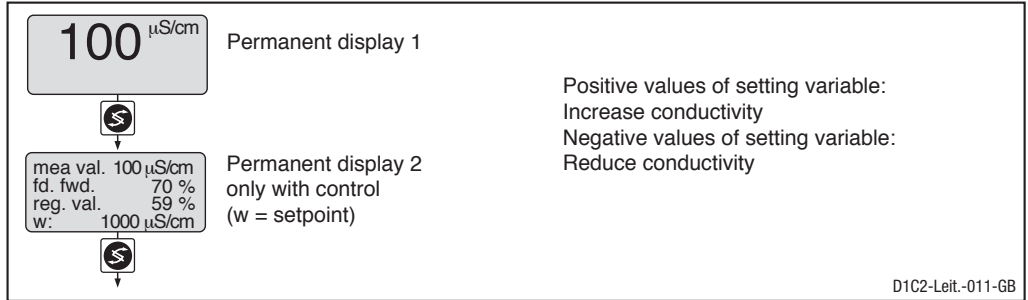

Calibration conductivity Measuring parameter

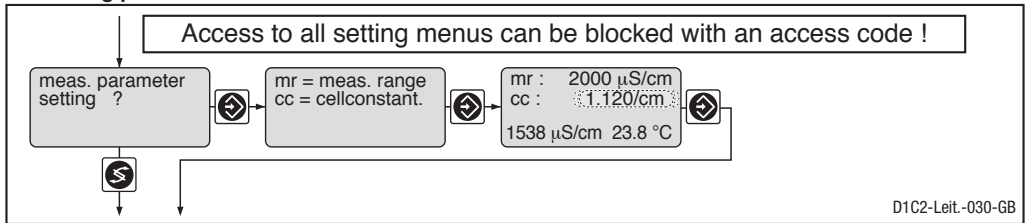

	Initial value	Possible values			Remarks
		Increment	Lower value	Upper value	
Cell constant cc	1.000/cm	0.0001/cm 0.001/cm 0.01/cm	0.0060/cm 0.150/cm 1.50/cm	0.1499/cm 1.499/cm 12.00/cm	cc can be adjusted for all mr over the complete area

The measured value can be adjusted to the actual conductivity value by changing the cell constants (arrow keys).

Limit values

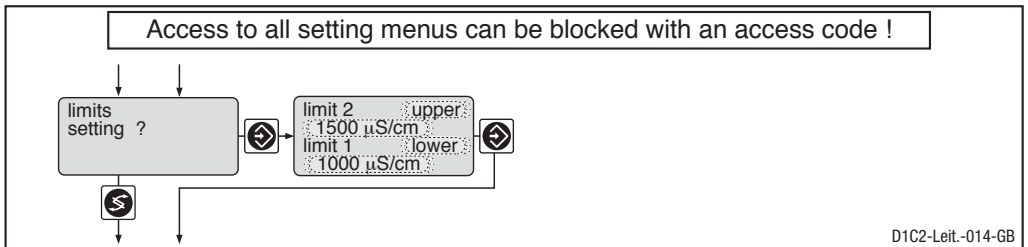

		Initial value	Possible values			Remarks
			Increment	Lower value	Upper value	
Type of limit transgression	Limit 1: Limit 2:	lower upper	lower upper off*			*only with limit value relay Measuring range 20 µS/cm Measuring range 200 µS/cm
Limit value	Limit 1:	10 µS/cm	0.01 µS/cm	-1 µS/cm	21 µS/cm	
	Limit 2:	15 µS/cm				
	Limit 1:	100 µS/cm	0.1 µS/cm	-10 µS/cm	210 µS/cm	
	Limit 2:	150 mS/cm				

Restricted Operating Menu / Description

	Initial value	Possible values			Remarks
		Increment	Lower value	Upper value	
Limit 1:	1000 $\mu\text{S/cm}$	1 $\mu\text{S/cm}$	-100 $\mu\text{S/cm}$	2100 $\mu\text{S/cm}$	Measuring range 2000 $\mu\text{S/cm}$
Limit 2:	1500 $\mu\text{S/cm}$				
Limit 1:	10 mS/cm	0.01 mS/cm	-1 mS/cm	21 mS/cm	Measuring range 20 mS/cm
Limit 2:	15 mS/cm				
Limit 1:	100 mS/cm	0.1 mS/cm	-10 mS/cm	210 mS/cm	Measuring range 200 mS/cm
Limit 2:	150 mS/cm				

Control

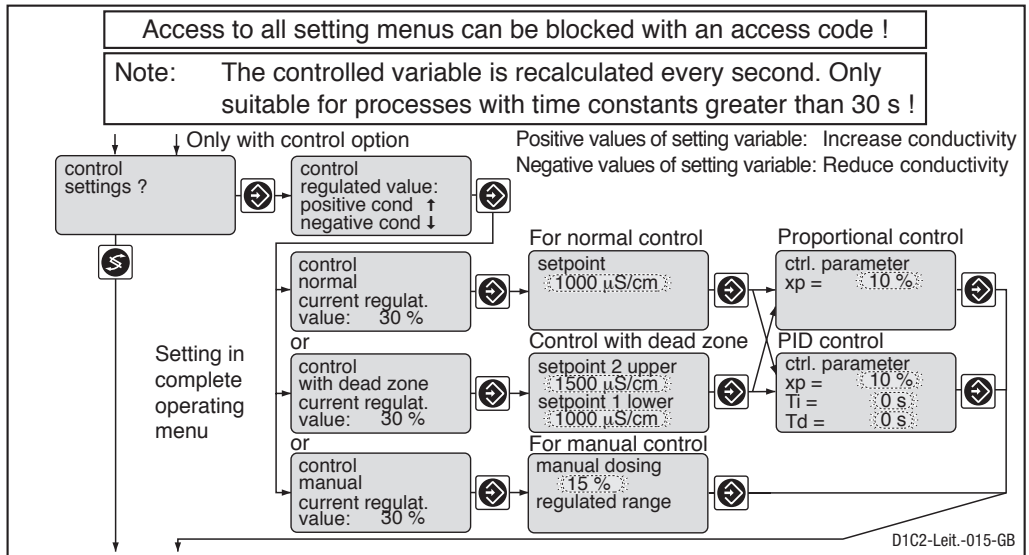

	Initial value	Possible values			Remarks
		Increment	Lower value	Upper value	
Setpoint	10 $\mu\text{S/cm}$	0.01 $\mu\text{S/cm}$	-1 $\mu\text{S/cm}$	21 $\mu\text{S/cm}$	Measuring range 20 $\mu\text{S/cm}$
	100 $\mu\text{S/cm}$	0.1 $\mu\text{S/cm}$	-10 $\mu\text{S/cm}$	210 $\mu\text{S/cm}$	Measuring range 200 $\mu\text{S/cm}$
	1000 $\mu\text{S/cm}$	1 $\mu\text{S/cm}$	-100 $\mu\text{S/cm}$	2100 $\mu\text{S/cm}$	Measuring range 2000 $\mu\text{S/cm}$
	10 mS/cm	0.01 mS/cm	-1 mS/cm	21 mS/cm	Measuring range 20 mS/cm
	100 mS/cm	0.1 mS/cm	-10 mS/cm	210 mS/cm	Measuring range 200 mS/cm
					2 setpoints necessary for control with dead zone. Setpoint 1 < setpoint 2 Adjustment of measuring range on page 9/14
Control parameter xp	10 %	1 %	1 %	500 %	xp referred to measuring range
Control parameter Ti	off	1 s	1 s	9999 s	Function off = 0 s
Control parameter Td	off	1 s	1 s	2500 s	Function off = 0 s
Manual metering	0 %	1 %	-100 %	+100 %	

Restricted Operating Menu / Description

Abbreviations for control variables:

x_p = 100 %/Kp (inverse proportional coefficient)

T_i = I controller integration time [s]

T_d = D controller differential time [s]

General settings

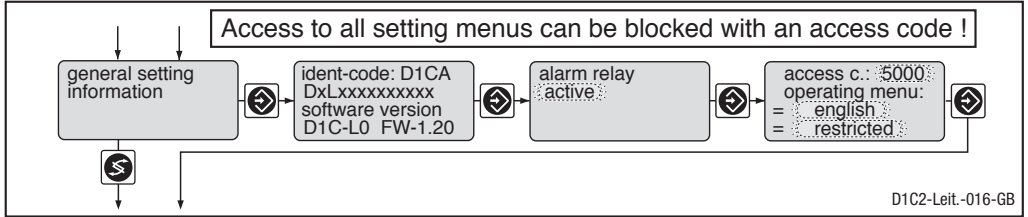

	Initial value	Possible values			Remarks
		Increment	Lower value	Upper value	
Alarm relay	active	active not active			
Access code	5000	1	1	9999	
Language	as per identity code	as per identity code			
Operating menu	restricted	restricted complete			

Access Code

Access to the setting menu can be prevented by setting up an access code. The DULCOMETER® D1C controller is supplied with the access code 5000 which permits free access to the setting menu. The calibration menu remains freely accessible even when access to the setting menu is blocked by the code.

8 Complete Operating Menu / Overview

All parameters of the controller can be set in the complete operating menu (access see previous page). The following overview shows the settings which can be selected:

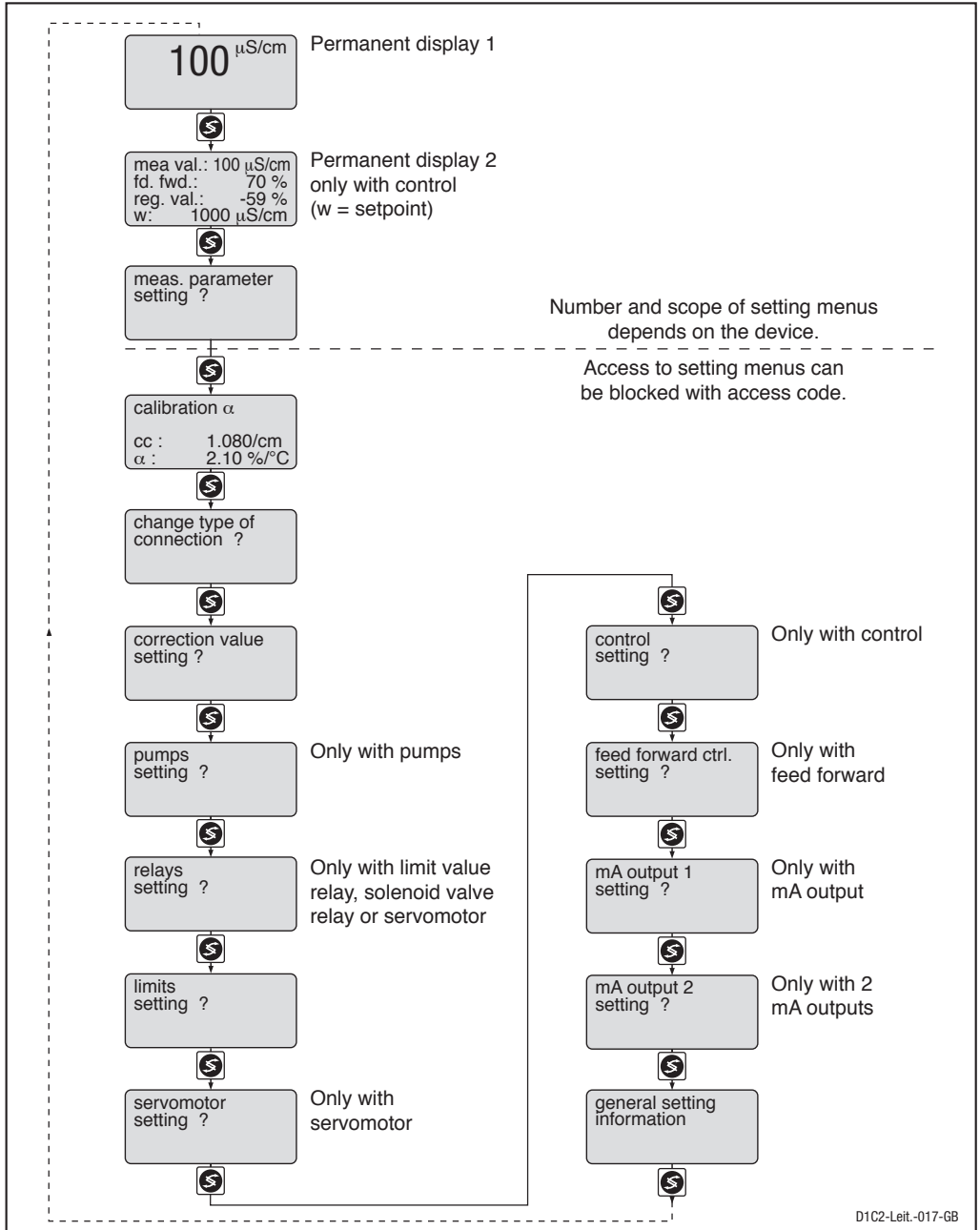

Complete Operating Menu / Description

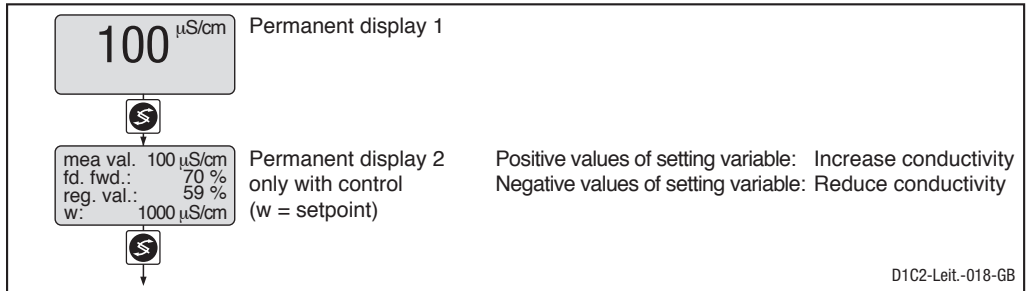

Measuring parameter

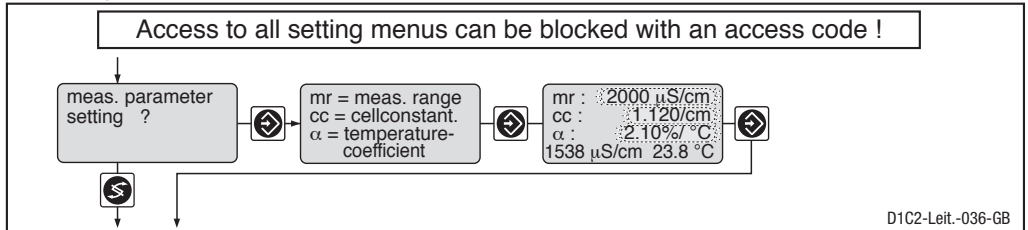

	Initial value	Possible values			Remarks
		Increment	Lower value	Upper value	
Measuring range mr	0...2000 $\mu\text{S}/\text{cm}$	0...20 $\mu\text{S}/\text{cm}$ 0...200 $\mu\text{S}/\text{cm}$ 0...2000 $\mu\text{S}/\text{cm}$ 0...20 mS/cm 0...200 mS/cm			Setpoints and limit values are switched to the corresponding startup values
Cell constant cc	1,000/cm	0.0001/cm 0.001/cm 0.01/cm	0.0060/cm 0.150/cm 1.50/cm	0.1499/cm 1.499/cm 12.00/cm	cc can be adjusted for all mr over the complete area
Temperature coefficient α	1.90 %/°C	0.01 %/°C	0 %/°C	10 %/°C	

The measured value can be adjusted to the actual conductivity value by changing the cell constants (arrow keys). Prerequisite is a known temperature coefficient and a constant temperature.



IMPORTANT

When changing the measuring range, metering and control are stopped, the setpoints, limit values, and the standard signal output are set to the corresponding startup values! Check these settings in all menus!

Calibrating temperature coefficient α

The temperature coefficient α is newly determined by a 2-point calibration. During calibration, the D1C sets the command outputs to "0". Exception: if a basic load or a manual control output were set, these are maintained during calibration. The standard signal outputs mA (measuring value or correction value) are frozen.



ATTENTION

The conductivity values you enter must be based on 25 °C. You must use the same solution when calibrating both temperatures!

Complete Operating Menu / Description

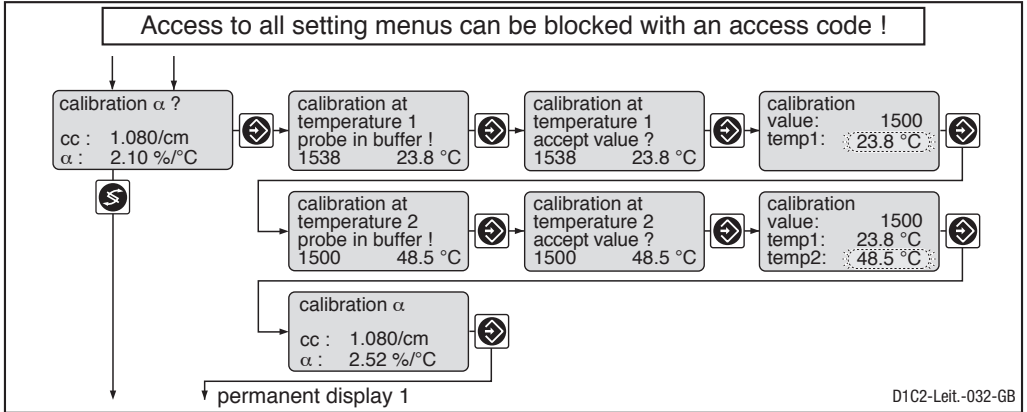

	Initial value	Possible values			Measuring range
		Increment	Lower value	Upper value	
Set sensor	Measuring value	0.01 $\mu\text{S/cm}$	-1 $\mu\text{S/cm}$	21 $\mu\text{S/cm}$	20 $\mu\text{S/cm}$
		0.1 $\mu\text{S/cm}$	-10 $\mu\text{S/cm}$	210 $\mu\text{S/cm}$	200 $\mu\text{S/cm}$
		1 $\mu\text{S/cm}$	-100 $\mu\text{S/cm}$	2100 $\mu\text{S/cm}$	2000 $\mu\text{S/cm}$
		0.01 mS/cm	-1 mS/cm	21 mS/cm	20 mS/cm
Set temperature	Correction value	0.1 $^{\circ}\text{C}$	0 $^{\circ}\text{C}$	100 $^{\circ}\text{C}$	200 mS/cm
		0.1 mS/cm	-10 mS/cm	210 mS/cm	200 mS/cm

Error message/Warning	Condition	Remarks
Temperature range restricted xx - 100 $^{\circ}\text{C}$		For the chosen temperature coefficient α , a correct reading can only be obtained for the displayed temperature range.
Temperature distance wrong	Δ temperature ≥ 10.0 $^{\circ}\text{C}$ Δ temperature ≤ 50.0 $^{\circ}\text{C}$	

Sensor connection

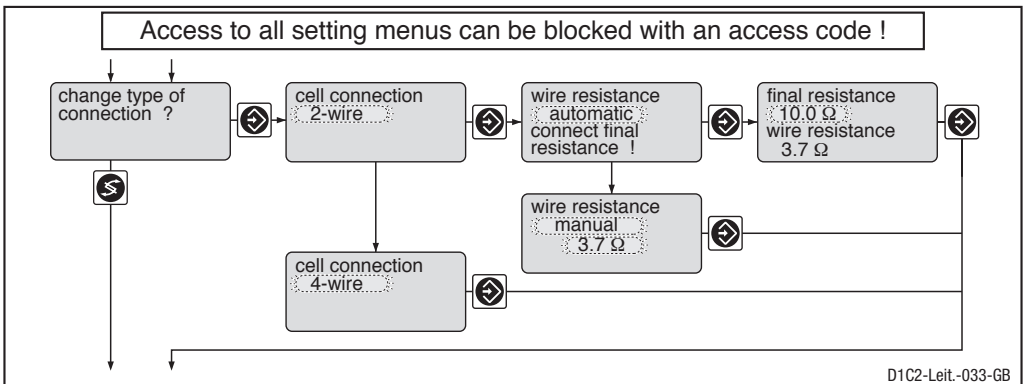

Complete Operating Menu / Description

	Initial value	Possible values			Remarks
		Increment	Lower value	Upper value	
Sensor connection	2-wire 4-wire	2-wire			
Determine wire resistance	manual	manual automatic			
Manual entry wire resistance	0.5 Ω	0.1 Ω	0 Ω	50 Ω	
Final resistance	10.0 Ω	0.1 Ω	10 Ω	50 Ω	

Correction value

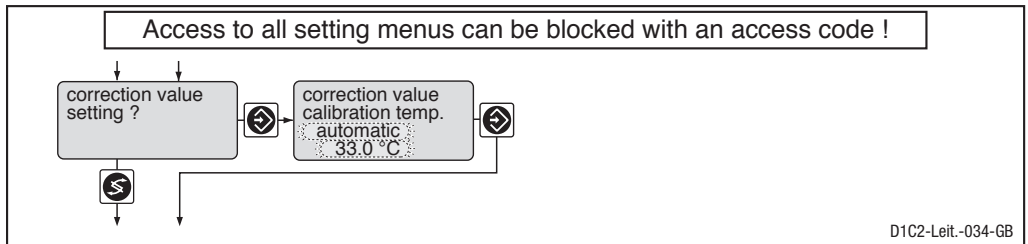

	Initial value	Possible values			Remarks
		Increment	Lower value	Upper value	
Type of temperature compensation	as per identity code	manual automatic off			
Manual temperature	25 °C	0.1 °C	0 °C	100 °C	
Automatic temperature	Correction value	0.1 °C	0 °C	100 °C	

Pumps

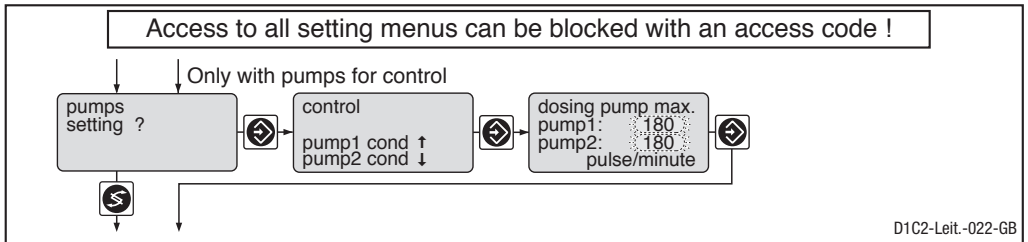

	Initial value	Possible values			Remarks
		Increment	Lower value	Upper value	
Max. stroke/minute of pumps 1 and 2	180	1	1	500	off = 0 strokes/min

Complete Operating Menu / Description

Relay for power control

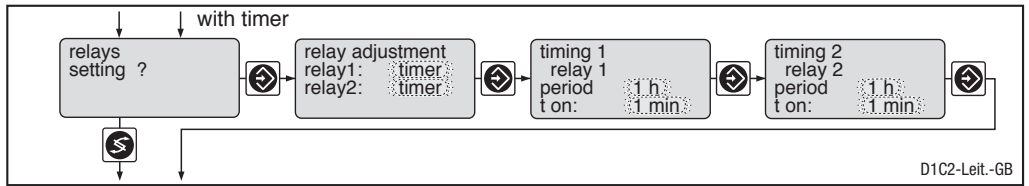
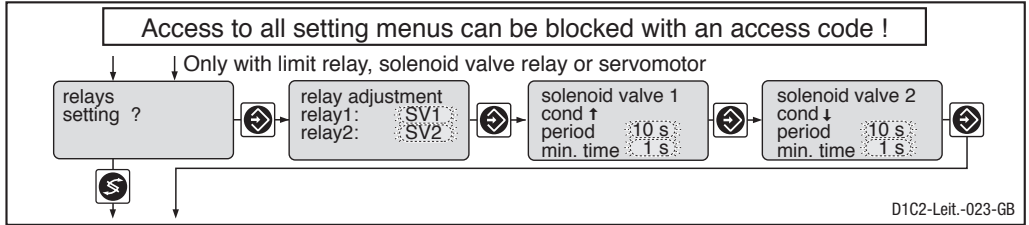

	Initial value	Possible values			Remarks
		Increment	Lower value	Upper value	
Relay adjustment	as per identity code				
Relay 1		Solenoid valve 1 Limit value 1* Actuator 1 Timer 1 Servomotor off			*For "limit value", the relays remain active, even in the event of a fault.
Relay 2		Solenoid valve 2 Limit value 2* Actuator 2 Timer 2 off			
Cycle min. time	10 s 1 s	1 s 1 s	10 s 1 s	9999 s Cycle/2	for solenoid valve for solenoid valve Set here the smallest permitted operating factor of the connected device.
Period (Cycle) t on	off 1 min	1 h 1 min	1 h / off 1 min	240 h 60 min	for timer for timer

NOTE

The limit value relay can be defined in such a way as to respond as a control element, i.e. if a limit value relay closes a circuit, it opens when a pause contact is activated and/or for a subsequent delay period t_d (if t_d is set to > 0 min in "General settings").

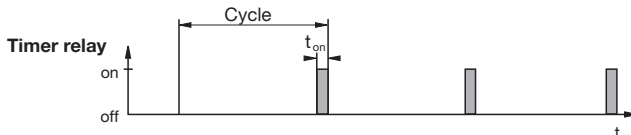

IMPORTANT

The timer will be reset if there is a drop in the power supply.

Complete Operating Menu / Description

At the end of the (timer) cycle time, the DULCOMETER® D1C closes the assigned relay for the duration of “t on” (timer). “Pause” interrupts the timer.

When the clock is shown in the LC display, the timer can be reset to the start of the cycle at precisely this point using the enter button.

The % figure in the LC display indicates the progress of the current cycle.

Timer relays may be used, e.g. for shock metering or sensor cleaning.

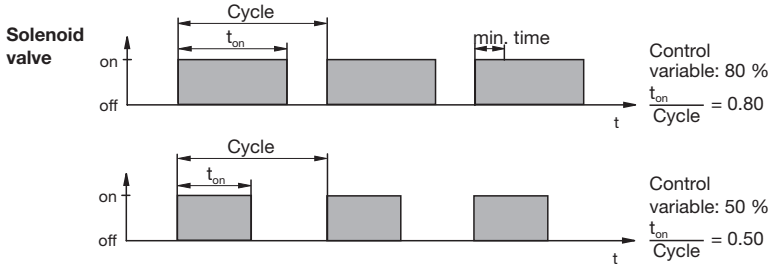

The switching time of the DULCOMETER® D1C (solenoid valve) depends on the actuating variable and the “min. time” (smallest permitted operating factor of the connected device).

The actuating variable determines the ratio t_{on}/cycle and thus the switching times (see fig. above).

The “min. time” influences the switching times in two situations:

a) theoretical switching time < min. time:

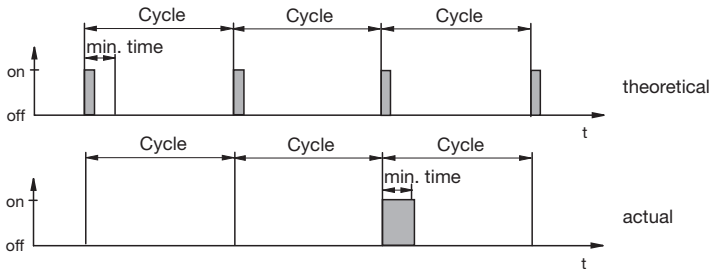

The DULCOMETER® D1C does not switch for a certain number of cycles until the sum of the theoretical switching times exceeds the “min. time”. Then the DULCOMETER® D1C switches for the duration of this total time.

b) theoretical switching time > (cycle - min. time) and calculated switching time < cycle

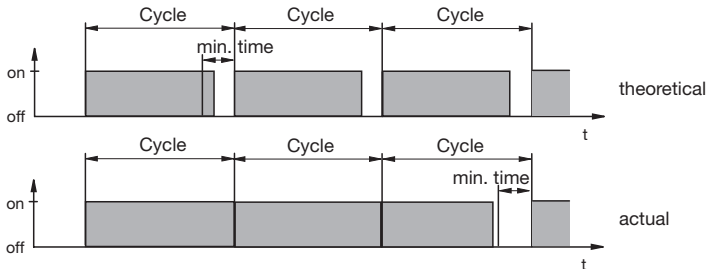

The DULCOMETER® D1C does not deactivate for a certain number of cycles until the differences between cycle and theoretical switching time exceed the “min. time”.

Complete Operating Menu / Description

Limit values

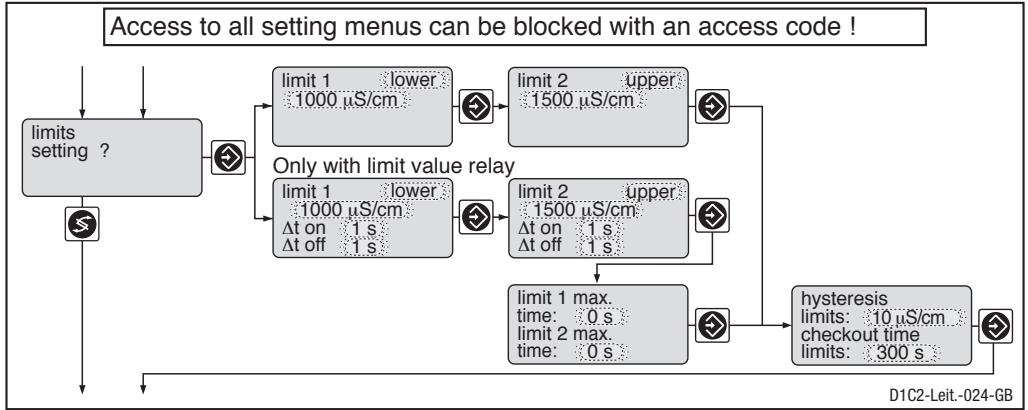

	Initial value	Possible values			Remarks
		Increment	Lower value	Upper value	
Type of limit Limit 1: transgression Limit 2:	lower upper	upper lower off*			Limit transgression when exceeding or dropping below value *only with limit value relay
Limit value 1 Limit value 2	100; 150 mS/cm 10; 15 mS/cm 1000; 1500 µS/cm 100; 150 µS/cm 10; 15 µS/cm	0.1 mS/cm 0.01 mS/cm 1 µS/cm 0.1 µS/cm 0.01 µS/cm	-10 mS/cm -1 mS/cm -100 µS/cm -10 µS/cm -1 µS/cm	210 mS/cm 21 mS/cm 2100 µS/cm 210 µS/cm 21 µS/cm	Meas. range 200 mS/cm Meas. range 20 mS/cm Meas. range 2000 µS/cm Meas. range 200 µS/cm Meas. range 20 µS/cm
Hysteresis limits	1 mS/cm 0.1 mS/cm 10 µS/cm 1.0 µS/cm 0.10 µS/cm	0.1 mS/cm 0.01 mS/cm 1 µS/cm 0.1 µS/cm 0.01 µS/cm	-0.4 mS/cm -0.04 mS/cm -4 µS/cm -0.4 µS/cm -0.04 µS/cm	210 mS/cm 21 mS/cm 2100 µS/cm 210 µS/cm 21 µS/cm	Effective in direction of "cancelling limit transgression"
Checkout time limits	off	1 s	1 s/off	9999 s	Result in message and alarm. off = 0 s: Function switched off, no message, no alarm
Controlling	on	on off			
Actuating direction limit value 1; limit value 2	active closed	active closed active open			Reacts as make contact Reacts as break contact
Switch-on delay Δt on	0 s	1 s	0 s	9999 s	
Switch-off delay Δt off	0 s	1 s	0 s	9999 s	

Complete Operating Menu / Description

Servomotor

The **operating range** is defined by the total resistance range of the feedback potentiometer. The maximum limit of the range actually used is set by defining the **control range**.



ATTENTION

- **Activation of the servomotor must be carried out with the same meticulous care as taken when calibrating a measuring sensor.**
- **To ensure correct operation, the activation time of the actuator used should not be less than 25 seconds for the control range from 0...100 %!**

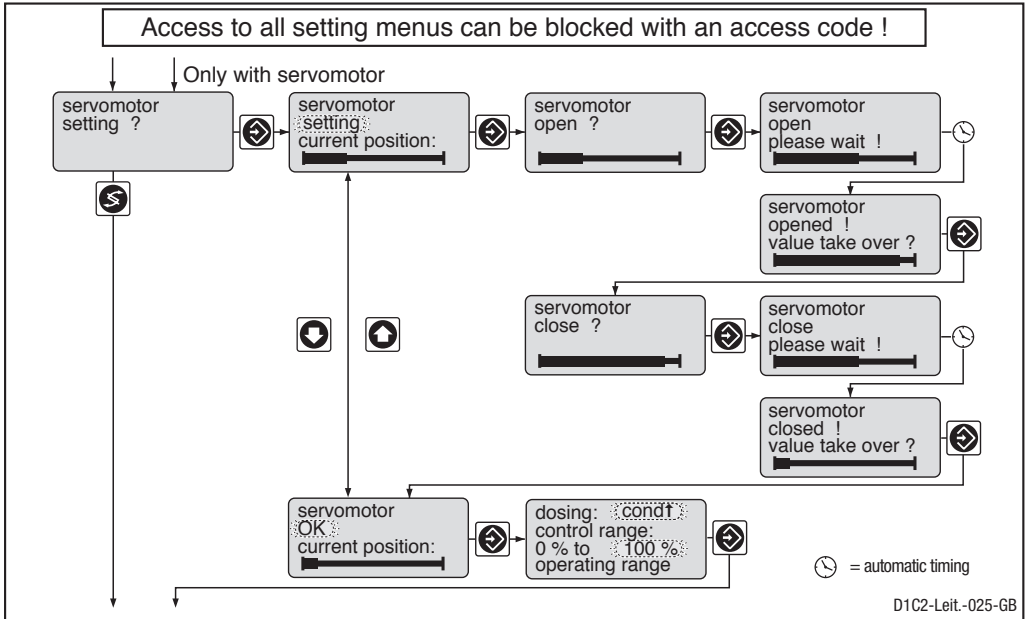

	Initial value	Possible values			Remarks
		Increment	Lower value	Upper value	
Servomotor	Setting	Setting ok off			
Control direction	cond. ↑	cond. ↑ cond. ↓			
Control range	100 %	1 %	10 %	100 %	in % of operating range

NOTE

- **If the broad bar is to the far right, the stroke adjustment motor is fully open.**
- **The continuous display shows the degree in % to which it is open (the greater the percentage, the more open the stroke adjustment motor).**

Complete Operating Menu / Description

Control

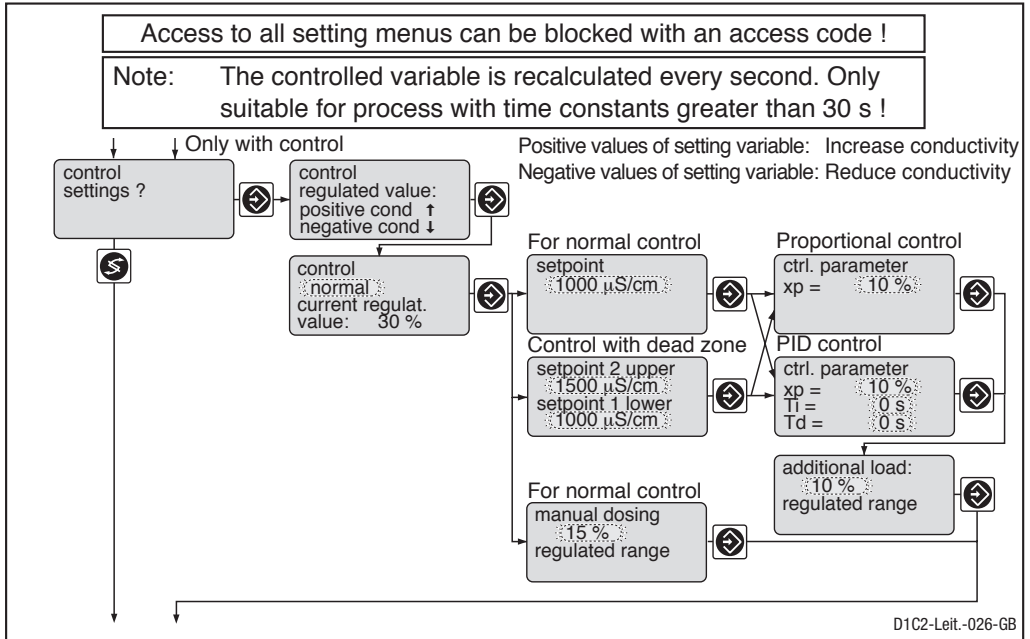

	Initial value	Possible values			Remarks
		Increment	Lower value	Upper value	
Control	normal	normal with dead zone manual			When controlling with dead zone, the feed forward control is not used for measured values within the dead zone
Setpoint setting	100 mS/cm 10 mS/cm 1000 µS/cm 100 µS/cm 10 µS/cm	0.1 mS/cm 0.01 mS/cm 1 µS/cm 0.1 µS/cm 0.01 µS/cm	-10 mS/cm -1 mS/cm -100 µS/cm -10 µS/cm -1 µS/cm	210 mS/cm 21 mS/cm 2100 µS/cm 210 µS/cm 21 µS/cm	Meas. range 200 mS/cm Meas. range 20 mS/cm Meas. range 2000 µS/cm Meas. range 200 µS/cm Meas. range 20 µS/cm Setpoint 2 ≥ setpoint 1
Control parameter xp	10 %	1 %	1 %	500 %	xp referred to measuring range
Control parameter Ti	off	1 s	1 s	9999 s	Function off = 0 s
Control parameter Td	off	1 s	1 s	2500 s	Function off = 0 s
Additional load	0 %	1 %	-100 %	+100 %	
Manual metering	0 %	1 %	-100 %	+100 %	

Abbreviations for control variables:

x_p = 100 %/Kp (inverse proportional coefficient)

T_i = I controller integration time [s]

T_d = D controller differential time [s]

Complete Operating Menu / Description

Feed forward control

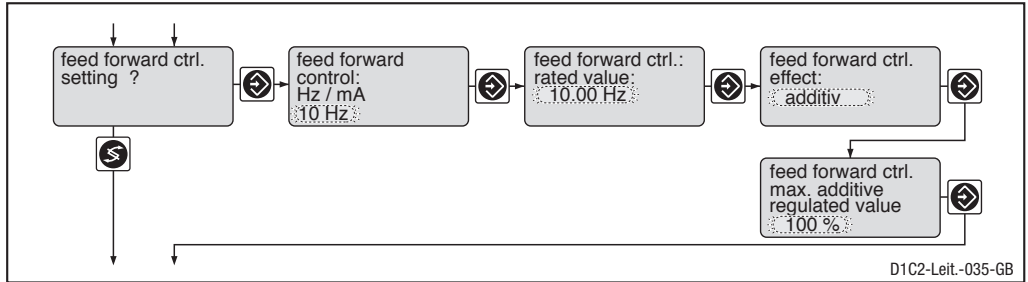

D1C2-Leit.-035-GB

	Initial value	Possible values			Remarks
		Increment	Lower value	Upper value	
Feed forward control (Flow)	as per identity code	None 10 Hz 500 Hz			Signal processing: Signal <0.02 Hz = no flow Signal <0.2 Hz = no flow Signal <0.2 mA = no flow Signal <4.2 mA = no flow
	with standard signal: 4–20 mA	0...20 mA 4...20 mA			
Feed forward control rated value	10 Hz 500 Hz 20 mA	0.01 Hz 1 Hz 0.01 mA	0.1 Hz 5 Hz 0/4 mA	10 Hz 500 Hz 20 mA	Dependent on signal type. Maximum limitation of range used.
Feed forward control effect	multiplicative	multiplicative additive			
Max. add. regulated value	100 %	1 %	-500 %	+500 %	Only with additive feed forward control

Standard signal output 1

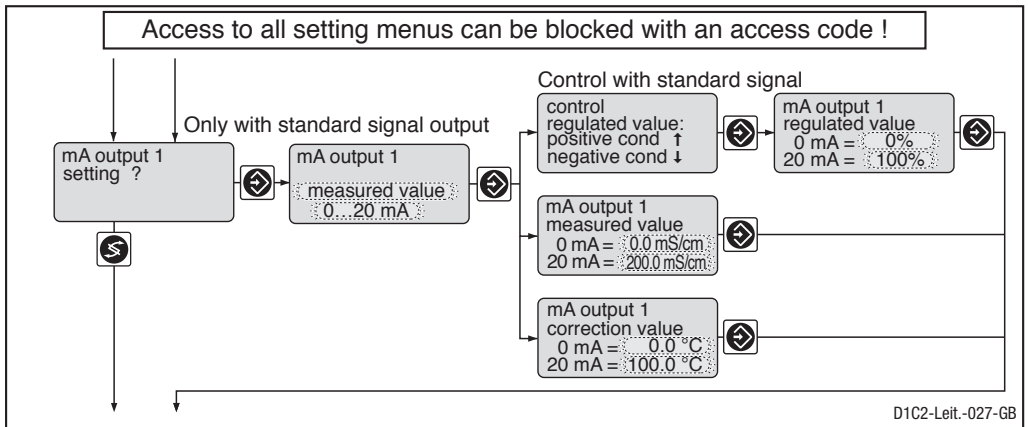

D1C2-Leit.-027-GB

Complete Operating Menu / Description

Standard signal output 2

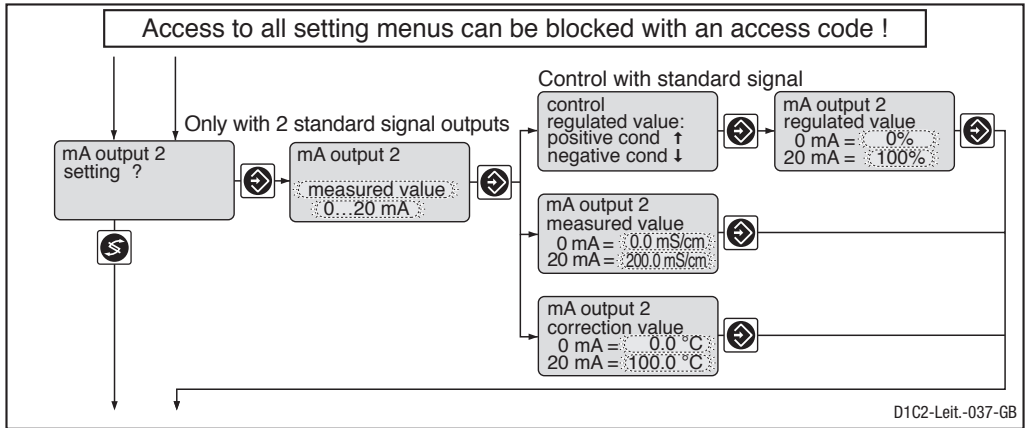

	Initial value	Possible values Increment	Lower value	Upper value	Remarks
Variable allocation	as per identity code	Measured value Controlled variable Correction value			If control applicable Only with correction variable
Output range	0...20 mA	0...20 mA 4...20 mA 3.6/4-20 mA			Reduction to 3.6 mA when alarm relay switches (not limit-value violation)
Range measured value	0-20 µS/cm 0-200 µS/cm 0-2000 µS/cm 0-20 mS/cm 0-200 mS/cm	0.01 µS/cm 0.1 µS/cm 1 µS/cm 0.01 mS/cm 0.1 mS/cm	-1 µS/cm -10 µS/cm -100 µS/cm -1 mS/cm -10 mS/cm	21 µS/cm 210 µS/cm 2100 µS/cm 21 mS/cm 210 mS/cm	Meas. range 20 µS/cm Meas. range 200 µS/cm Meas. range 2000 µS/cm Meas. range 20 mS/cm Meas. range 200 mS/cm
Range controlled variable	0 %...+100 %	1 %	-100 %	+100 %	Minimum range 1 %
Range correction value	0....100 °C	0.1 °C	0.0 °C	100 °C	Minimum range 1 °C

General setting

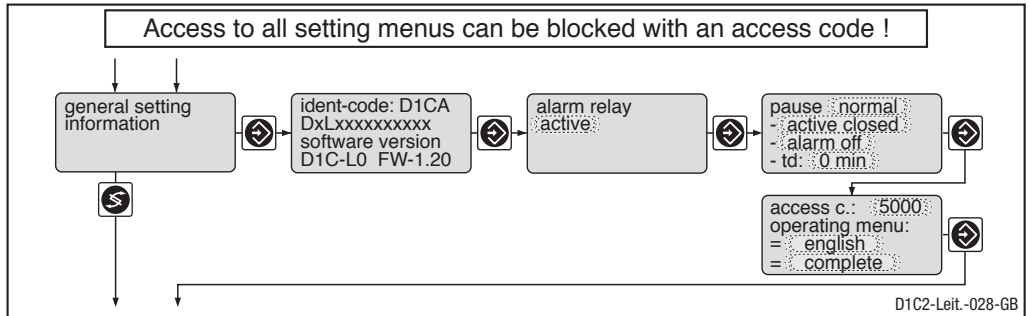

Complete Operating Menu / Description

	Initial value	Possible values		Upper value	Remarks
		Increment	Lower value		
Alarm relay	active	active not active			Reacts as make contact Reacts as break contact Alarm relay can be triggered by pause contact
Pause	normal	normal hold			
Control input pause	active closed	active closed active open			
Alarm pause	off	off on			
td	0 min	1 min	0 min	60 min	
Access code	5000	1	1	9999	
Language	as per identity code	as per identity code			
Operating menu	complete	restricted complete			

Pause Normal

If the pause switch is off, the DULCOMETER® D1C sets the operating outputs to “0” for as long as the pause switch is off or for a set time delay t_d (if t_d is set to > 0 min). Whilst the pause switch is off, the D1C establishes the P-proportion in the background.

With PID-control (identity code characteristics “control characteristic” = 2): the I-proportion is stored when the pause is switched off (I-proportion then usually only present if $T_n > 0$ has been selected in the “Control setting?” setting menu).

Exception: the standard signal outputs mA for the measured value or correction value are not affected by the pause.

After pause is activated, the operating outputs remain at “0” for the length of the time delay t_d . The time delay t_d must be set up in such a way that in this time e.g. sample water (process-specific current concentration) flows to the sensor.

With PID-control (identity code characteristics “control characteristic” = 2): The control variable output resulting from the pause and the expiry of the time delay t_d is reconciled jointly with the current P-component and (if T_n is set > 0) with the stored I-component.

Pause hold

If the pause switch is off, the DULCOMETER® D1C freezes the operating output at the most recent value for as long as the pause switch is off or for a set time delay t_d (if t_d is set to > 0 min). Whilst the pause switch is off, the D1C establishes the P-proportion in the background.

With PID-control (identity code characteristics “control characteristic” = 2):

Even the mA standard signal outputs for measured value or correction value are frozen.

After pause is activated, the operating outputs remain frozen for the length of the time delay t_d . The time delay t_d must be set up in such a way that in this time e.g. sample water (process-specific current concentration) flows to the sensor.

With PID-control (identity code characteristics “control characteristic” = 2): The control variable output resulting from the pause and the expiry of the time delay t_d is reconciled jointly with the current P-proportion and (if T_n is set > 0) with the newly established I-proportion.

Access Code

Access to the setting menu can be prevented by setting up an access code. The DULCOMETER® D1C controller is supplied with the access code 5000 which permits free access to the setting menu. The calibration menu remains freely accessible even when access to the setting menu is blocked by the code.

9 Fault / Remarks / Troubleshooting

Fault	Fault text	Symbol	Effect On metering	Effect On control	Alarm with acknowledgement	Remarks	Remedy
Measured value	<i>mS-meas. range</i> ↑↓ Check <i>mS-probe</i>	€	Basic load	Stop	Yes	Measured value out of measuring range.	Check range adjustment Check sensor and cable connection
Correction measured variable Signal exceeds/drops below value* upper/limit temperature exceeded	<i>Check te-input</i> <i>te-limit</i> ↓	€	Basic load	Stop	Yes	Signal <3.0 ±0.2 mA or >23 ±0.2 mA $\alpha \geq 4 \text{ } ^\circ\text{C}$	Check sensor, transducer and cable connection
Feed forward control Signal exceeds/drops below value* Signal drops below multiplicative	<i>Check feed forward input</i> "	€	Basic load	Stop	Yes	Signal <3.0 ±0.2 mA or >23 ±0.2 mA Value last valid is used	Check sensor, transducer and cable connection
Limit value violation Control "on" Control "off"	<i>mS-limit 1</i> ↓ ↓ <i>mS-limit 2</i> ↓↓	€	Stop or basic load	Stop	Yes	Function detachable	Define cause, reset values if necessary
Servomotor Position not reached	<i>Servomotor defective</i> <i>System error</i>	€	Stop	Stop	Yes	Servomotor closes Electronic data defective	Check servomotor Call in service
Operation	Note text	Symbol	Effect On metering	Effect On control	Alarm with acknowledgement	Remarks	Remedy
Pause contact	<i>Pause</i>	€	Stop	Stop	No/Yes*	No further fault check	-
	<i>Pause/hold</i>	€		PI part frozen			
Stop button	<i>Stop</i>	€	Stop	Stop	No	Relay drops out	-
During servomotor setting Position feedback wrong Upper position <40 % max. value Lower position >30 % range	<i>Direction check</i> <i>Final value too small</i> <i>Final value too big</i>	€				Without correct adjustment the last valid values are still used	Check connection of relay, potentiometer Adjust the operation region of the servomotor correctly

* Depends on whether "alarm off" or "alarm on" in "General Settings".