

Operating Instructions

DULCOMETER® D1C

Part 2: Adjustment and Operation,
Measured variable chlorite

D1C2-Cit-001-GB

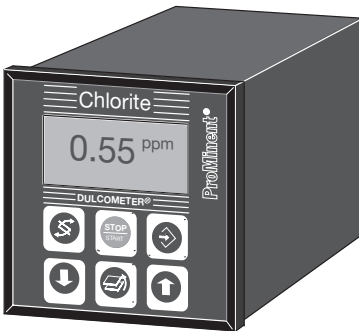

Type D



Type W

D1C A

Please enter the identity code of your device here.

**Please completely read through operating instructions! · Do not discard!
The warranty shall be invalidated by damage caused by operating errors!**

2 Contents / General User Information

	Page
1 Device Identification / Identity Code	2
2 General User Information	3
3 Device Overview / Controls	4
4 Functional Description	5
5 Display Symbols	6
6 Operation	7
7 Restricted Operating Menu	8
Overview	8
Description	9
8 Complete Operating Menu	12
Overview	12
Description	13
9 EC Declaration of Conformity	25
10 Troubleshooting	26

General User Information

These operating instructions describe the technical data and function of the series DULCOMETER® D1C controller, provide detailed safety information and are divided into clear steps.





IMPORTANT

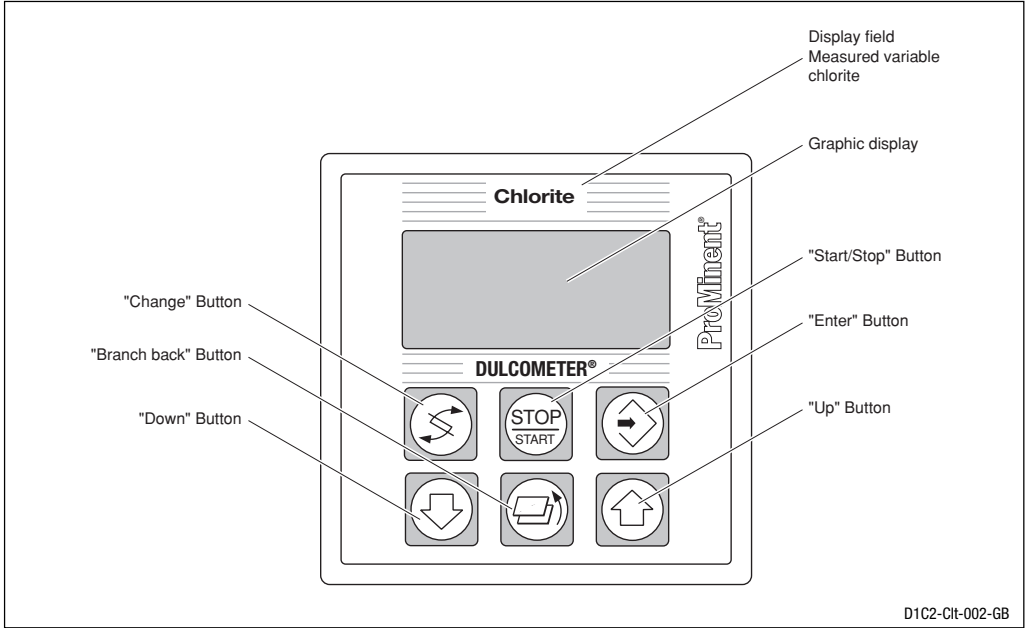

- ***Please observe the parts of these operating instructions applicable to your particular version! This is indicated in the Section “Device Identification / Identity Code”!***
- ***Correct measuring and dosing is only possible in the case of impeccable operation of the probe. The probe has to be calibrated / checked regularly!***

3 Device Overview / Controls



D1C2-Clt-002-GB

	<p>CHANGE Button To change over within a menu level and to change from one variable to another within a menu point.</p>
	<p>START/STOP Button Start/stop of control and metering function.</p>
	<p>ENTER Button To accept, confirm or save a displayed value or status. For alarm acknowledgement.</p>

	<p>UP Button To increase a displayed numerical value and to change variables (flashing display).</p>
	<p>BRANCH BACK Button Back to permanent display or to start of relevant setting menu.</p>
	<p>DOWN Button To decrease a displayed numerical value and to change variables (flashing display).</p>

4 Functional Description

NOTE

Please refer to the description of the complete operating menu in Section 8 for a detailed description of the individual characteristics of the DULCOMETER® D1C controller!

4.1 Operating Menu

The D1C controller permits settings to be made in two different menus. All values are preset and can be changed in the **complete operating menu**.

The controller is delivered with a **restricted operating menu** so that the D1C controller can be used effectively in many applications from the very onset. If adaptations prove to be necessary, all relevant parameters can then be accessed by switching over to the complete operating menu (see "General settings").

4.2 Access Code

Access to the setting menu can be prevented by setting up an access code. The D1C controller is supplied with the access code 5000 which permits free access to the setting menu. The calibration menu remains freely accessible even when access to the setting menu is blocked by the code.

4.3 Control

The D1C can operate as a proportional controller or as a PID controller - dependent on the device version (see identity code) and the setting.

The controlled variable is recalculated once a second. Control procedures which require rapid correction of setpoint deviations (less than approx. 30 seconds) cannot be processed with this controller. The cycle times must be taken into consideration when activating solenoid valves (pulse length) in the same way as their running times when activating servomotors (3-point).

Via the control input pause, the control function (selection of controlled variable) can be switched off. The calculation of the controlled variable starts again after cessation of "pause".

4.4 Feed Forward Control

The D1C controller can process a signal of a feed forward control. Depending on the device version (see identity code) and the setting, this signal can be obtained in any form of a 0–20 mA or 4–20 mA signal or as a digital contact signal with the maximum frequencies 10 Hz or 500 Hz.

During start-up, the zero point has to be checked. The multiplicative feed forward control is not designed for switching off permanently the actuating variable (signal ≈ 0).

This signal can be used, for example, for flow-proportional metering (multiplicative effect) or feed forward-dependent basic load metering (additive effect). The result of control variable calculation from the proportional or PID control is multiplied by or added to the feed forward signal. A multiplicative feed forward variable at the level of the set rated value carries over the calculated control variable unchanged into the controlled variable:

$$\text{Controlled variable} = \text{Feed forward variable} / \text{rated value} \times \text{calculated control variable}$$

An additive feed forward variable at the level of the rated value results in maximum controlled variable:

$$\text{Controlled variable (max. 100 \%)} = \text{Feed forward variable} / \text{rated value} \times \text{max. controlled variable} + \text{calculated control variable}$$

4.5 Error Messages

Error messages and information are indicated on the bottom line in the permanent display 1. Errors to be acknowledged (acknowledgement switches off the alarm relay) are indicated by the "E". Errors/notes which still apply after acknowledgement are indicated alternately. During correction variable processing (temperature for correction of pH-value), the value is indicated in the same line as the error/note. Faults which are rectified of their own accord due to changed operating situations are removed from the permanent display without the need for acknowledgement.

5 Display Symbols

The display of the DULCOMETER® D1C controller uses the following symbols:

Description	Comment	Symbol
Limit value transgression Relay 1, upper	Symbol left	↑
Relay 1, lower	Symbol left	↓
Relay 2, upper	Symbol right	↑
Relay 2, lower	Symbol right	↓
Metering pump 1 (chlorite) Control off	Symbol left	■
Control on	Symbol left	□
Metering pump 2 (De-Clt) Control off	Symbol right	■
Control on	Symbol right	□
Solenoid valve 1 (chlorite) Control off	Symbol left	▲
Control on	Symbol left	△
Solenoid valve 2 (De-Clt) Control off	Symbol right	▲
Control on	Symbol right	△
Servomotor Control, open relay		▲ △
Control, close relay		△ ▲
Without control		▲ ▲
Position feedback	Thickness of bar increases from left to right during opening	▬
Stop button pressed		O
Manual metering		M
Fault		ε

6 Operation

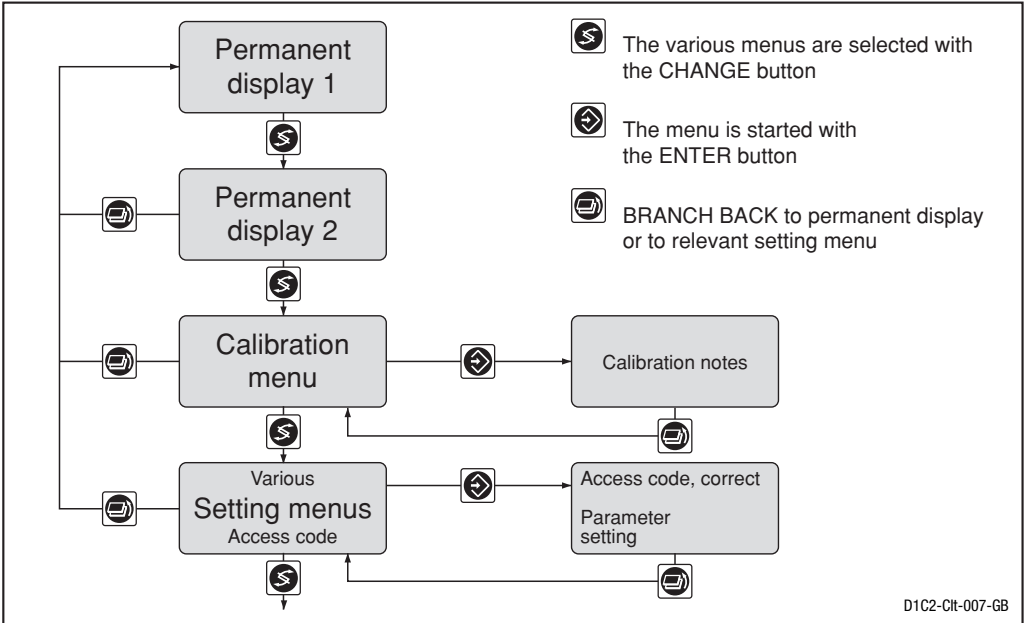

NOTE

Access to the setting menus can be barred with the access code!

The number and scope of setting menus is dependent on the device version!

If the access code is selected correctly in a setting menu, then the following setting menus are also accessible!

If within a period of 10 minutes no button is pushed, the unit automatically branches back from the calibrating menu or a setting menu to the permanent display 1.

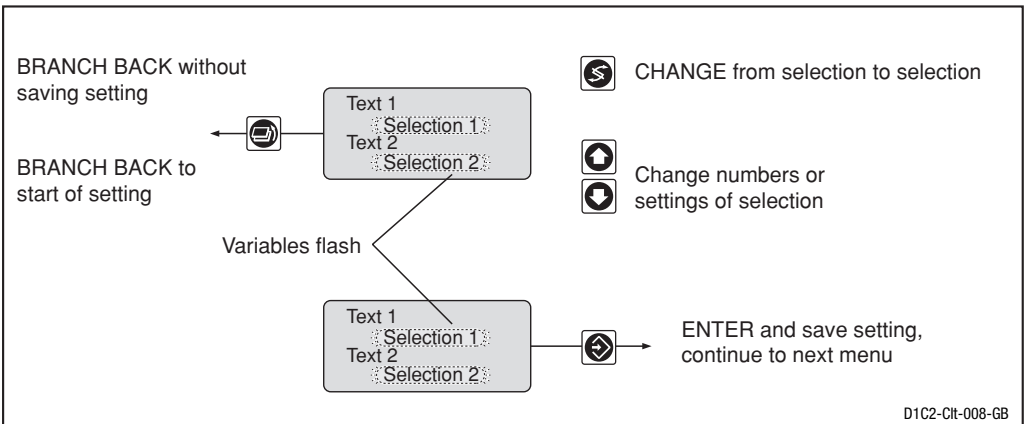

7 Restricted Operating Menu / Overview

The restricted operating menu permits simple operation of the most important parameters. The following overview shows the settings which can be selected:

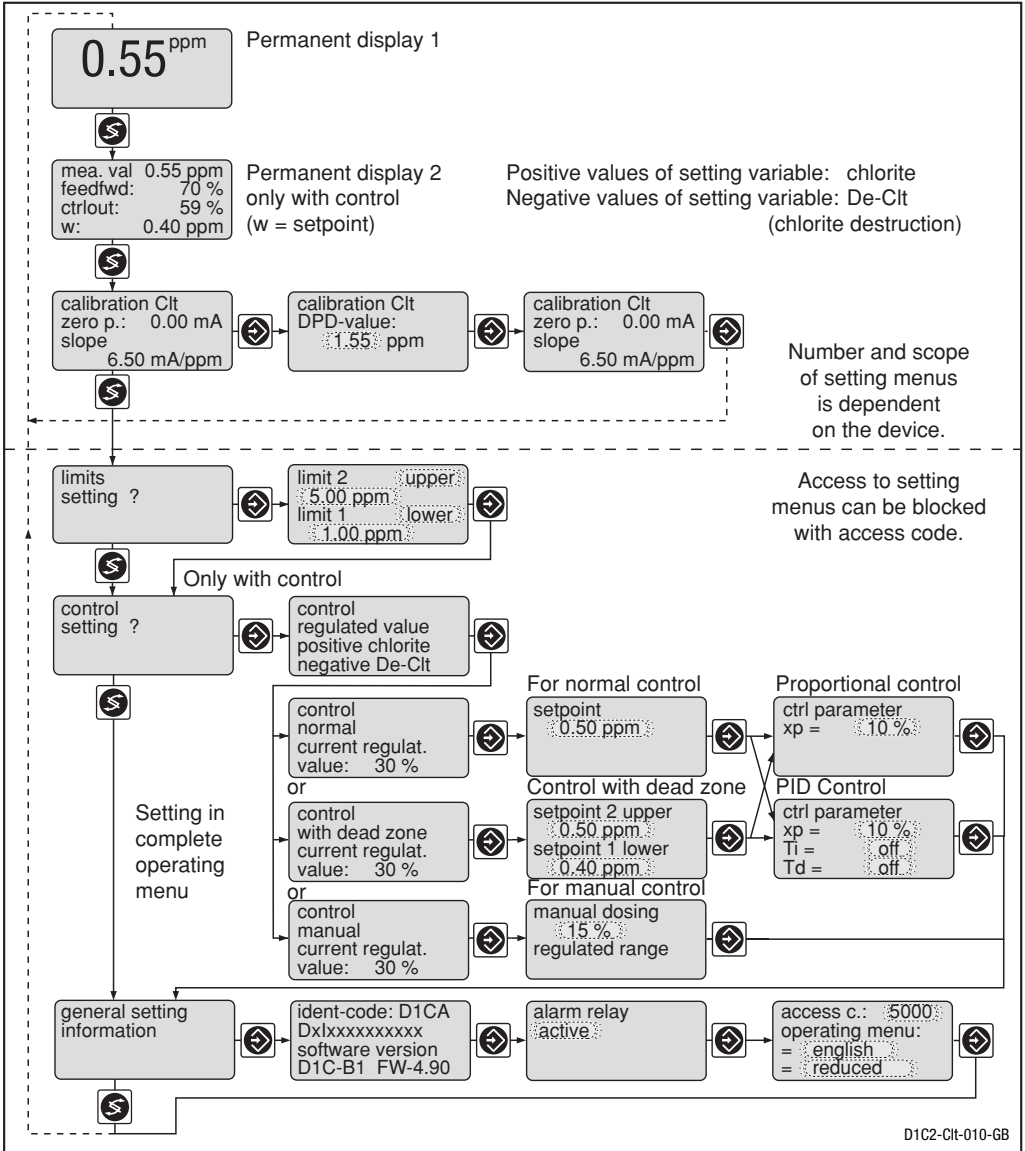

Restricted Operating Menu / Description

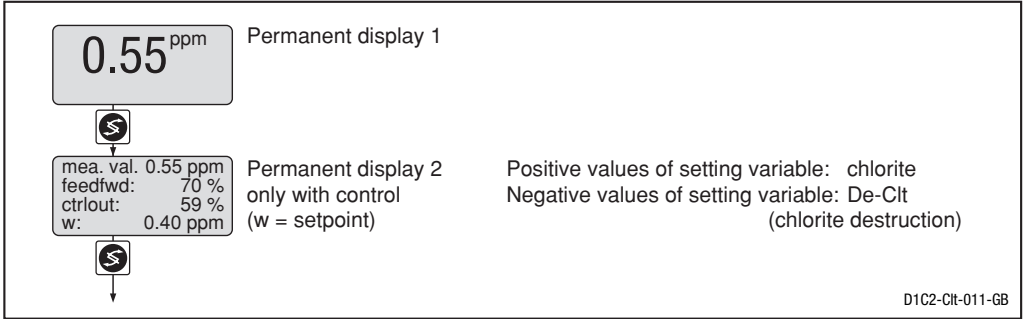

Calibrating the Chlorite Probe

During calibration, the control function persists. The standard signal of the output (measured value) remains unchanged. The measured value registered during the start of the calibration is proposed as the DPD value; this value is adjustable (arrow keys!). Calibration is only possible if the DPD value is $\geq 2\%$ of the measuring range. On successful completion of calibration, all error checks which refer to the measured value are restarted.



ATTENTION

The measuring range of the probe must agree with the set measuring range (factory setting: 0–2 ppm). The measuring range must be reset prior to calibration (refer to page 15).

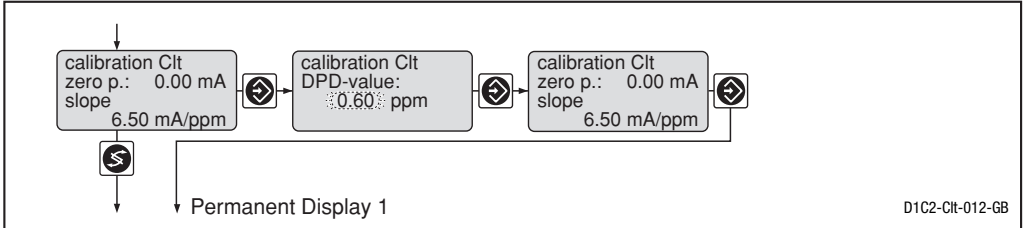

	Initial value	Possible values			Remarks
		Increment	Lower value	Upper value	
Measured value		0.01 ppm	-0.20 ppm	2.20 ppm	for measurement range up to 2 ppm
		0.001 ppm	-0.050 ppm	0.550 ppm	for measurement range up to 0.5 ppm

Error message	Condition	Effect
Calibration Clt not possible! Probe slope too low	ClO_2^- slope too low ($<25\%$ of norm slope)	Calibrate again
Calibration Clt not possible! Probe slope too high	ClO_2^- slope too high ($>300\%$ of norm slope)	Calibrate again
DPD value too low DPD $> x.xx$ ppm	DPD $<2\%$ measuring range	

Restricted Operating Menu / Description

Limits

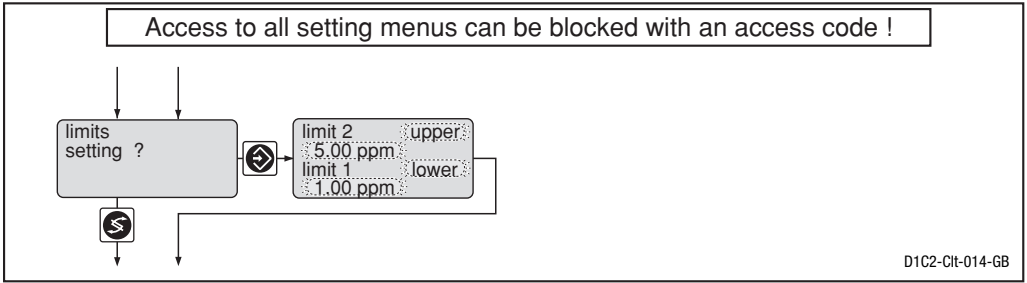

	Initial value	Possible values			Remarks
		Increment	Lower value	Upper value	
Type of limit transgression	Limit 1: lower Limit 2: upper	upper lower off *)			Limit transgression when exceeding or dropping below value *) only with limit relays for CLT 1-mA-0.5 ppm
Limit value	Limit 1: 0.025 ppm Limit 2: 0.375 ppm	0.001 ppm	-0.05 ppm	0.550 ppm	
	Limit 1: 0.10 ppm Limit 2: 1.50 ppm	0.01 ppm	-0.20 ppm	2.20 ppm	for CLT 1-mA-2 ppm

Control

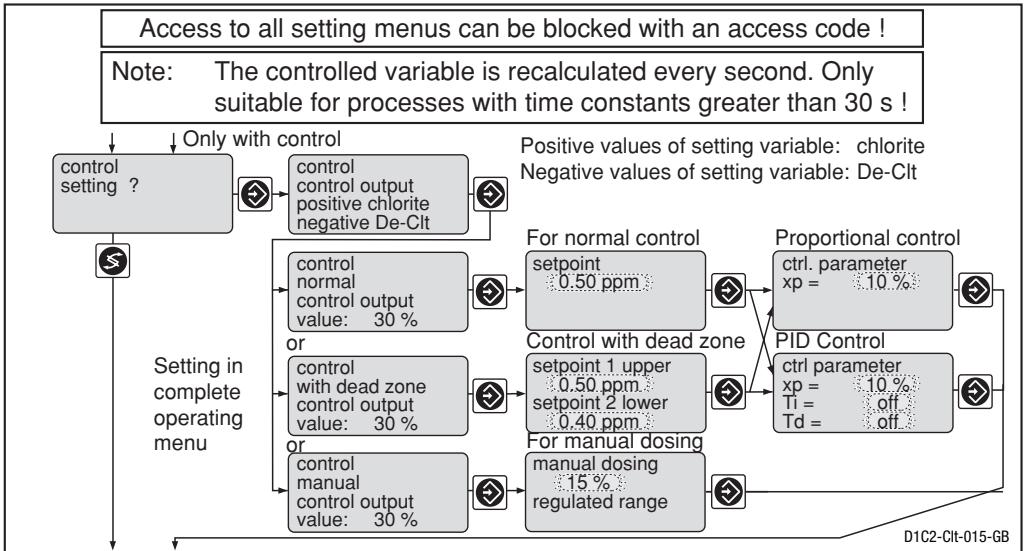

Restricted Operating Menu / Description

	Initial value	Possible values			Remarks
		Increment	Lower value	Upper value	
Setpoint	0.50 ppm	0.01 ppm	lower limit measuring range	upper limit measuring range	2 setpoints necessary for control with dead zone. Setpoint 1 > setpoint 2
Control parameter xp	10 %	1 %	1 %	500 %	xp referred to measuring range
Control parameter Ti	off	1 s	1 s	9999 s	Function off = 0 s
Control parameter Td	off	1 s	1 s	2500 s	Function off = 0 s
Manual metering	0 %	1 %	-100 %	+100 %	

General Settings

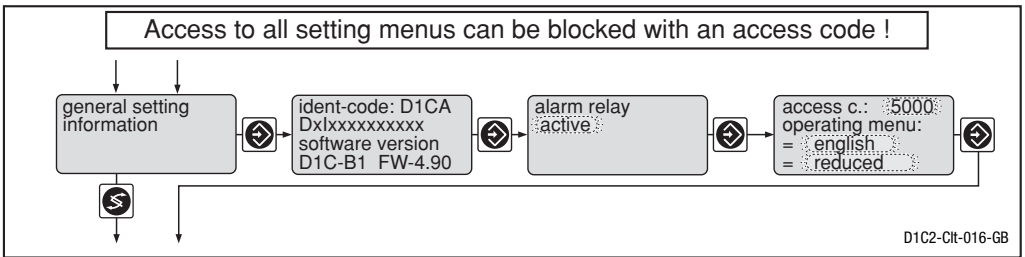

	Initial value	Possible values			Remarks
		Increment	Lower value	Upper value	
Alarm relay	active	active not active			
Access code	5000	1	1	9999	
Language	as per identity code	German English French Italian Dutch Spanish Portuguese Czech Japanese (as per identity code)			
Operating menu	restricted	restricted complete			

8 Complete Operating Menu / Overview

All parameters of the controller can be set in the complete operating menu (access see previous page). The following overview shows the settings which can be selected:

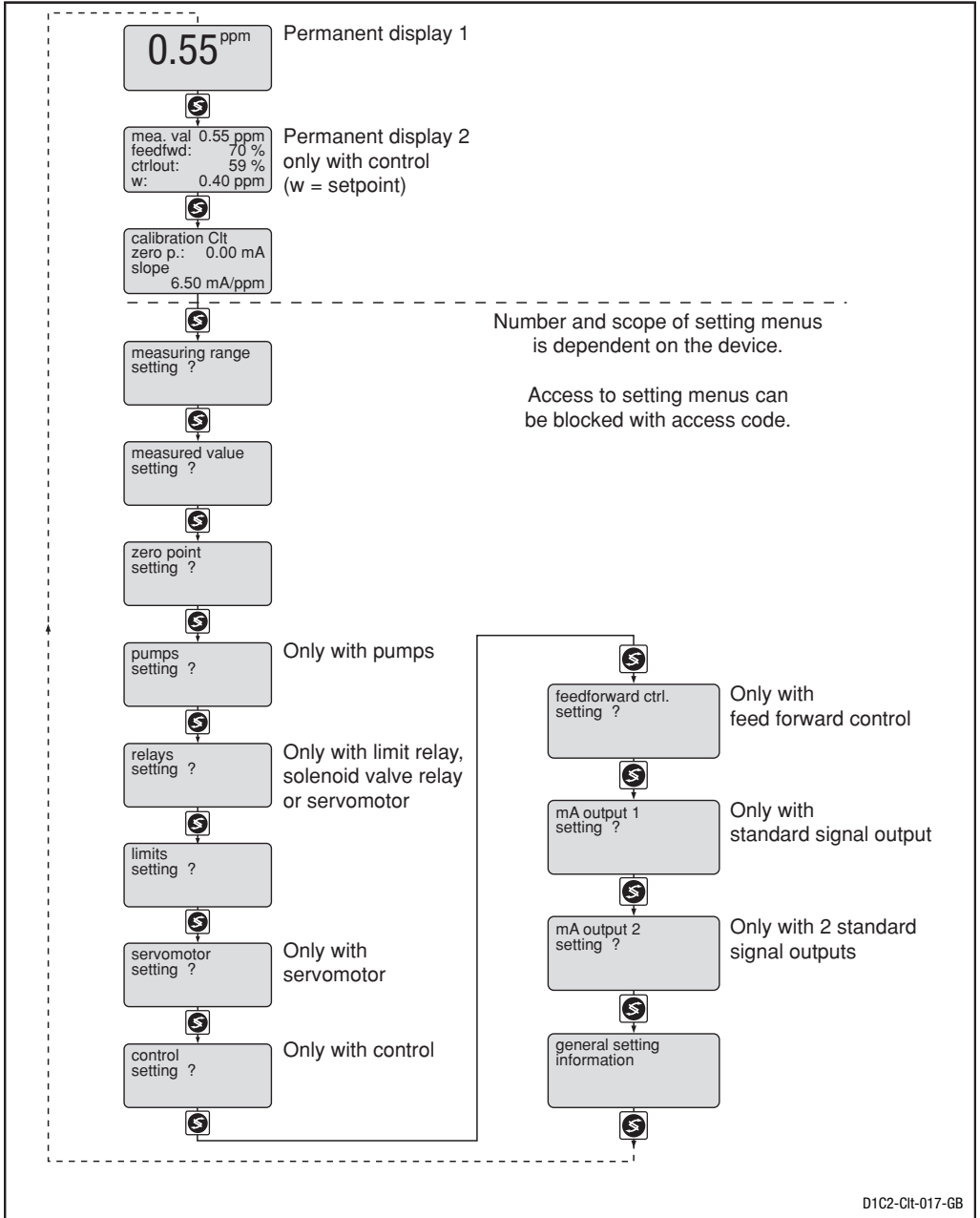

Complete Operating Menu / Description

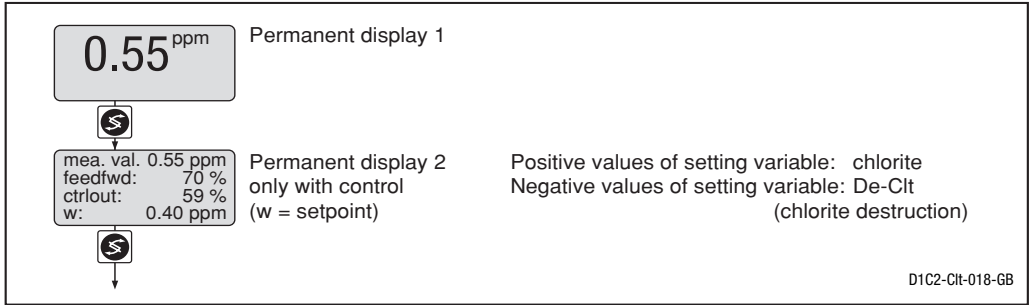

Calibrating the Chlorite Probe (zero point and slope)

The control function is retained during the calibration procedure. The standard signal of the output (measured value) is not changed. The measured value frozen at the start of calibration is offered as the DPD value; this value is adjustable (arrow keys!). Calibration is only possible when the DPD value is $\geq 2\%$ of the measurement range. Once calibration has been successfully completed, all fault tracing procedures which refer to the measured value are restarted.

Zero point calibration must be carried out under real conditions in water free of chlorite. Calibration is normally only necessary when measuring at the lower limit of the measuring range.



ATTENTION

The measuring range of the probe must agree with the set measuring range (factory setting: 0-2 ppm). The measuring range must be reset prior to calibration (refer to page 15).

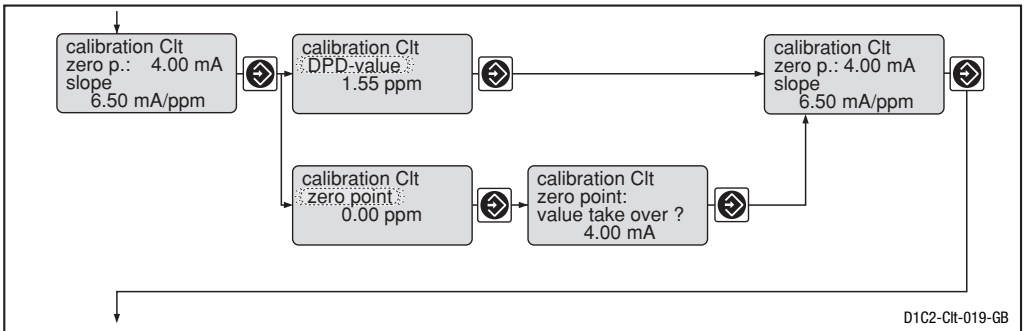

	Initial value	Possible values			Remarks
		Increment	Lower value	Upper value	
	Measured value	0.01 ppm	-0.20 ppm	2.20 ppm	for measurement range up to 2 ppm
		0.001 ppm	-0.050 ppm	0.550 ppm	for measurement range up to 0.5 ppm

Complete Operating Menu / Description

Error message	Condition	Effect
Calibration Clt not possible! Probe slope too low	ClO ₂ ⁻ slope too low (<25 % of norm slope)	Calibrate again
Calibration Clt not possible! Probe slope too high	ClO ₂ ⁻ slope too high (>300 % of norm slope)	Calibrate again
DPD value too low DPD > x.xx ppm	DPD <2 % of measuring range	
Zero point too low Zero point too high	< 3 mA > 5 mA at 2 ppm > 6 mA at 0.5 ppm	Check probe/cable Repeat calibration in chlorite-free water

Measuring Range

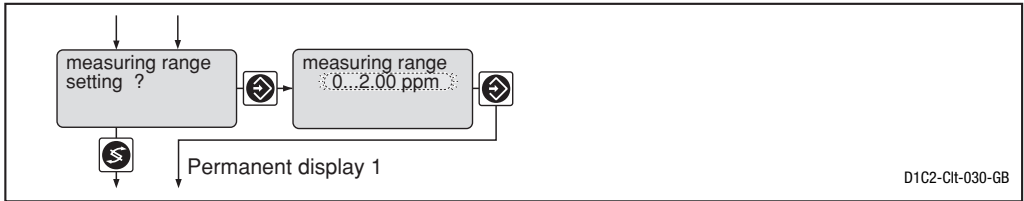

	Initial value	Possible values		Remarks
		Increment	Lower value	
Measuring range	0...2 ppm	0...0.5 ppm 0...2 ppm		

IMPORTANT
If the area allocation is changed, the chlorite must be re-calibrated and all the menu settings must be checked!

Measured Value

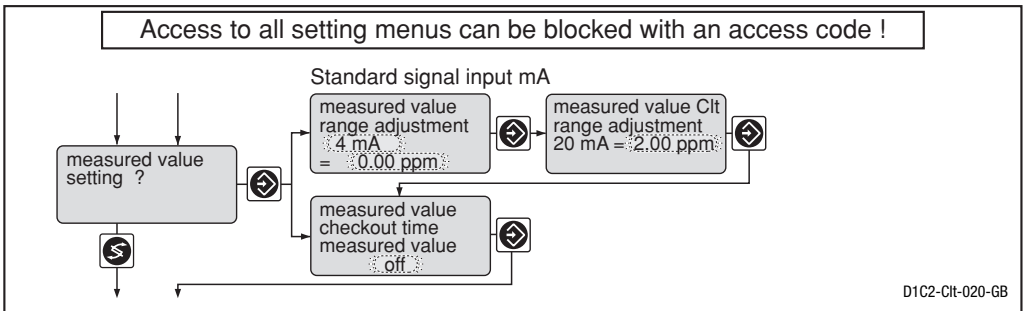

IMPORTANT
If the area allocation is changed, the chlorite must be re-calibrated and all the menu settings must be checked!

Complete Operating Menu / Description

	Initial value	Possible values			Remarks
		Increment	Lower value	Upper value	
Standard signal input lower signal limit	4 mA	0 mA 4 mA			
Allocated measured value lower	0 ppm 0 ppm	0.01 ppm 0.001 ppm	-0.20 ppm -0.05 ppm	2.20 ppm 0.550 ppm	for CLT1-mA-2 ppm for CLT1-mA-0.5 ppm
upper	2.0 ppm 2.0 ppm	0.01 ppm 0.001 ppm	-0.20 ppm -0.05 ppm	2.20 ppm 0.550 ppm	for CLT1-mA-2 ppm for CLT1-mA-0.5 ppm
Checkout time	off	1 s	1 s	9999 s	Constant measurement signal results in message and alarm. Function off = 0 s

Zero point

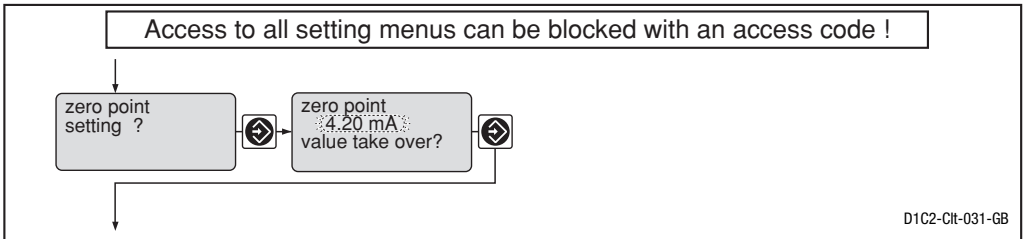

	Initial value	Possible values			Remarks
		Increment	Lower value	Upper value	
Zero point setting CLT 1-mA-0.5 ppm CLT 1-mA-2 ppm	4.80 mA 4.20 mA	0.01 mA	3.80 mA	6.00 mA 5.00 mA	

Pumps

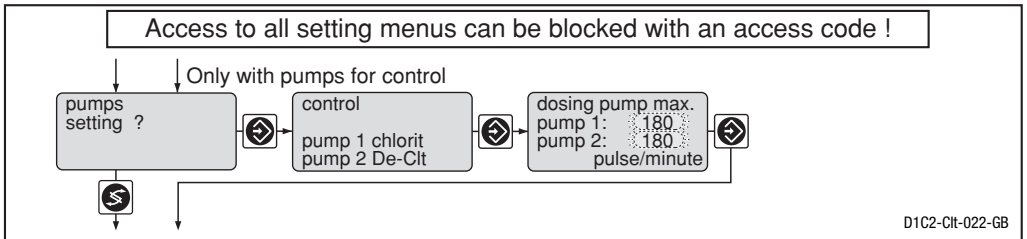

	Initial value	Possible values			Remarks
		Increment	Lower value	Upper value	
Max. stroke/minute of pumps 1 and 2	180	1	1	500	off = 0 strokes/min

Complete Operating Menu / Description

Relay for power control

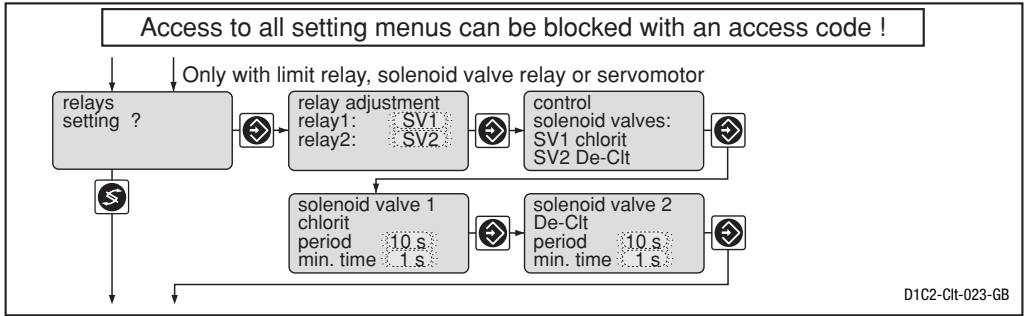

	Initial value	Possible values			Remarks
		Increment	Lower value	Upper value	
Relay adjustment	as per identity code				
Relay 1		Solenoid valve 1 Limit value 1* Actuator 1 off			*For "limit value", the relays remain active, even in the event of a fault.
Relay 2		Solenoid valve 2 Limit value 2* Actuator 2 off			
Cycle	10 s	1 s	10 s	9999 s	
min. time	1 s	1 s	1 s	Cycle/2	

Complete Operating Menu / Description

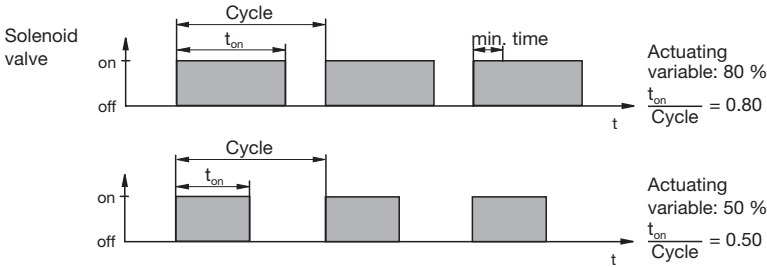

The switching time of the DULCOMETER® D1C (solenoid valve) depends on the actuating variable and the “min. time” (smallest permitted operating factor of the connected device).

The actuating variable determines the ratio t_{on}/cycle and thus the switching times (see fig. above).

The “min. time” influences the switching times in two situations:

a) theoretical switching time < min. time:

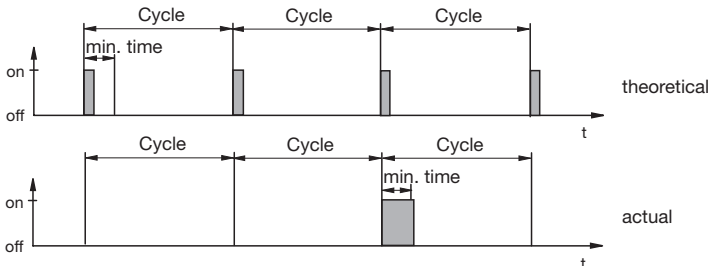

The DULCOMETER® D1C does not switch for a certain number of cycles until the sum of the theoretical switching times exceeds the “min. time”. Then the DULCOMETER® D1C switches for the duration of this total time.

b) theoretical switching time > (cycle - min. time) and calculated switching time < cycle

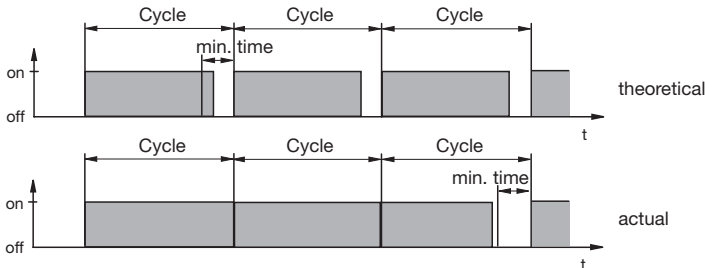

The DULCOMETER® D1C does not deactivate for a certain number of cycles until the differences between cycle and theoretical switching time exceed the “min. time”.

Complete Operating Menu / Description

Limit values

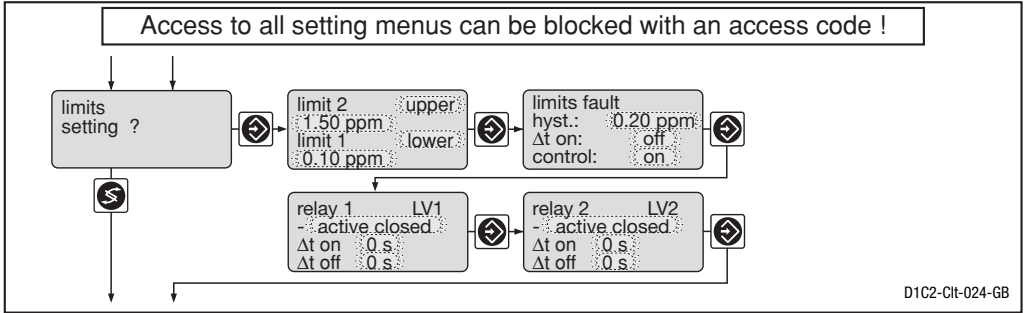

	Initial value	Possible values			Remarks
		Increment	Lower value	Upper value	
Type of limit transgression	Limit 1: lower Limit 2: upper	upper lower off *)			Limit transgression when exceeding or dropping below value *) only with limit relay for CLT 1-mA-0.5 ppm
Limit value	Limit 1: 0.025 ppm Limit 2: 0.375 ppm	0.001 ppm	-0.05 ppm	0.550 ppm	
Limit value	Limit 1: 0.10 ppm Limit 2: 1.50 ppm	0.01 ppm	-0.20 ppm	2.20 ppm	for CLT 1-mA-2 ppm
Switch-on delay Δt on	0 s	1 s	0 s	9999 s	
Switch-off delay Δt off	0 s	1 s	0 s	9999 s	
Hysteresis limits	0.010 ppm 0.04 ppm	0.001 ppm 0.01 ppm	0 ppm 0 ppm	0.550 ppm 2.20 ppm	Effective in direction of "cancelling limit transgression"
Checkout time limits	off	1 s	1 s	9999 s	Results in message and alarm. off = 0 s: Function switched off, no message, no alarm

Complete Operating Menu / Description

Servomotor

Activation of the servomotor must be carried out with the same meticulous care as taken when calibrating a measuring probe. The **operating range** is defined by the total resistance range of the feedback potentiometer. The maximum limit of the range actually used is set by defining the **control range**.



CAUTION

To ensure correct operation, the activation time of the actuator used should not be less than 25 seconds for the control range from 0...100 %!

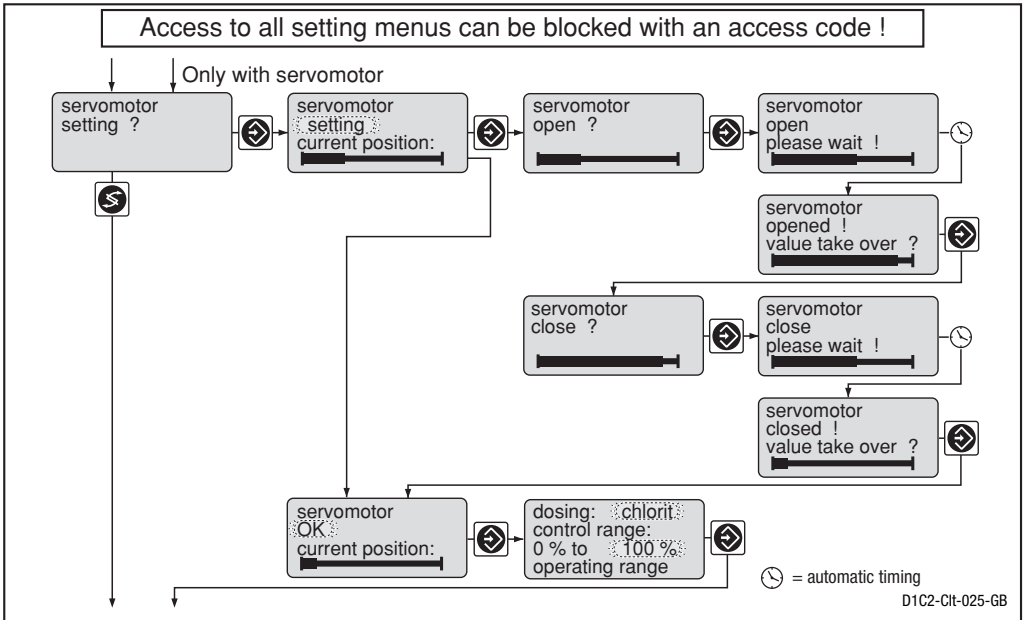

	Initial value	Possible values		Lower value	Upper value	Remarks
		Increment				
Servomotor	Setting	Setting ok off				
Control direction	Chlorite	Chlorite De-Cit				
Control range	100 %	1 %	10 %	100 %		in % of operating range

Complete Operating Menu / Description

Control

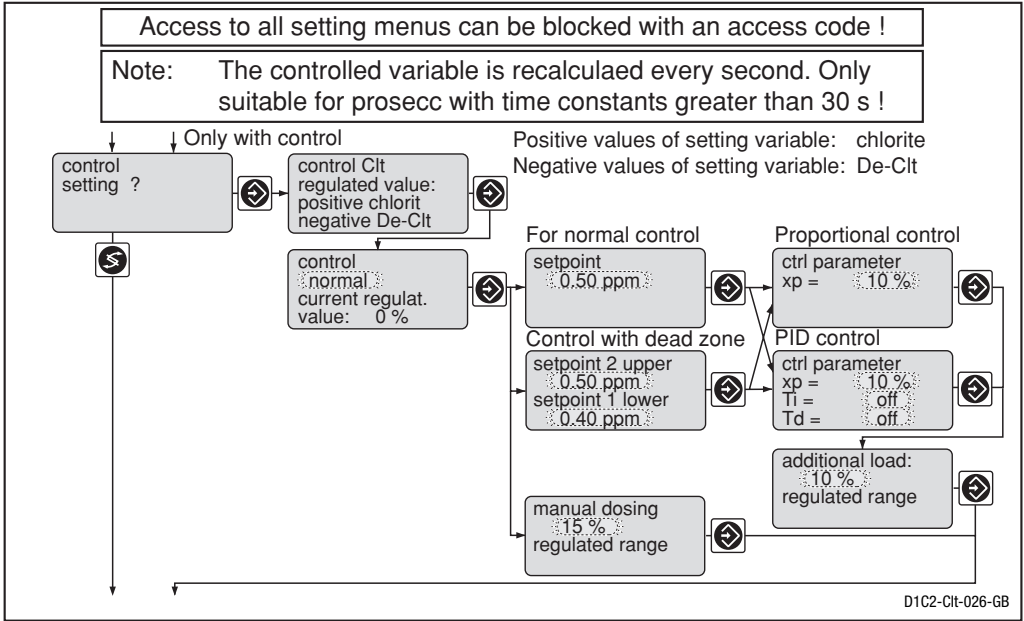

	Initial value	Possible values			Remarks
		Increment	Lower value	Upper value	
Control	normal	normal with dead zone manual			When controlling with dead zone, the regulated value is not used for measured values within the dead zone. 2 setpoints necessary for control with dead zone. Setpoint 2 ≥ Setpoint 1
Setpoint setting	0.100 ppm 0.20 ppm	0.001 ppm 0.01 ppm	-0.025 ppm -0.10 ppm	0.525 ppm 2.10 ppm	
Control parameter xp	10 %	1 %	1 %	500 %	xp referred to measuring range
Control parameter Ti	off	1 s	1 s	9999 s	Function off = 0 s
Control parameter Td	off	1 s	1 s	2500 s	Function off = 0 s
Additional basic load	0 %	1 %	-100 %	+100 %	
Manual metering	0 %	1 %	-100 %	+100 %	

Abbreviations for control variables:

x_p : 100 %/Kp (inverse proportional coefficient)

T_i : Integration time of I-controller [s]

T_d : Differential time of D-controller [s]

Complete Operating Menu / Description

Feed forward control

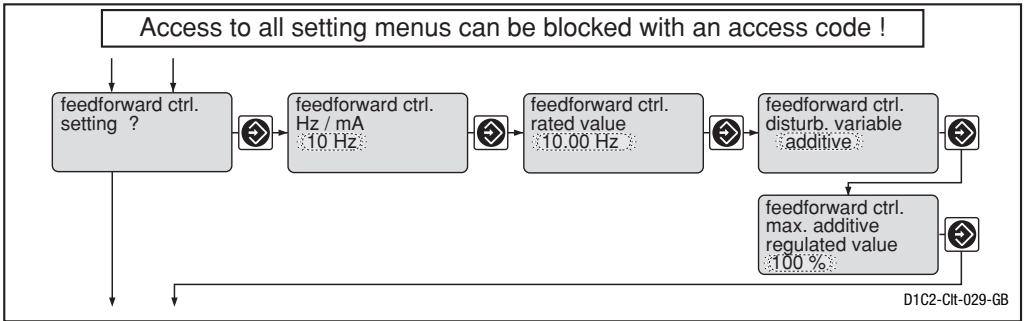

	Initial value	Possible values			Remarks
		Increment	Lower value	Upper value	
Feed forward control (Flow)	as per identity code	None 10 Hz 500 Hz			Signal processing: Signal <0.02 Hz = No flow Signal <0.2 Hz = No flow Signal <0.2 mA = No flow Signal <4.2 mA = No flow
	at standard signal: 4–20 mA	0...20 mA 4...20 mA			
Feed forward control rated value	10 Hz 500 Hz 20 mA	0.01 Hz 1 Hz 0.1 mA	0.1 Hz 1 Hz 0/4 mA	10 Hz 500 Hz 20 mA	
Feed forward control effect	multiplicative	multiplicative additive			
Max. add. regulated value	100 %	1 %	-500 %	+500 %	only with add. feed forward control

Complete Operating Menu / Description

Standard Signal Output 1

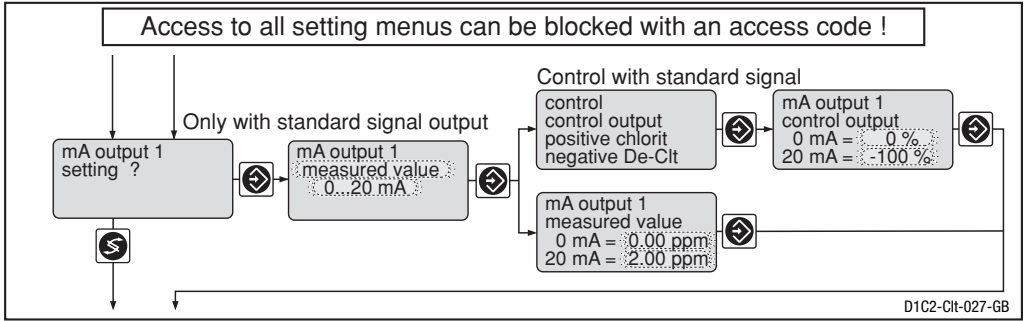

Standard Signal Output 2

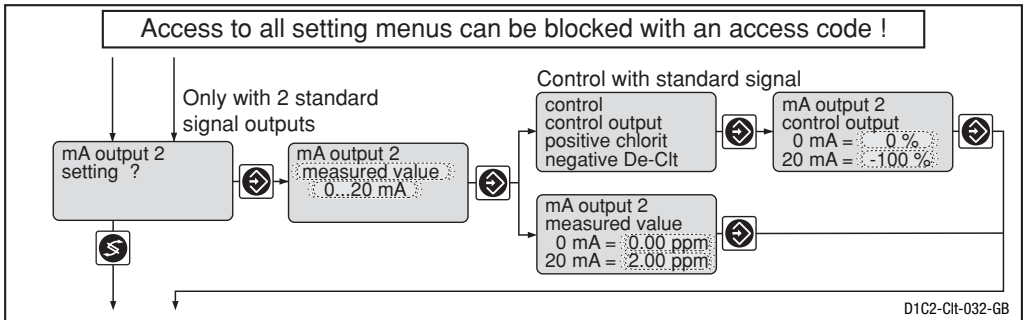

	Initial value	Possible values Increment	Lower value	Upper value	Remarks
Variable allocation	as per identity code	Measured value Control output			If control is present
Output range	0...20 mA	0...20 mA 4...20 mA			
Range measured value	0...1.00 ppm 0...0.500 ppm	0.01 ppm 0.001 ppm	-0.20 ppm -0.05 ppm	2.20 ppm 0.550 ppm	for CLT1-mA-2 ppm for CLT1-mA-0.5 ppm
Range controlled variable	-100 %...0 %	1 %	-100 %	+100 %	Minimum range 1 %

Complete Operating Menu / Description

General setting

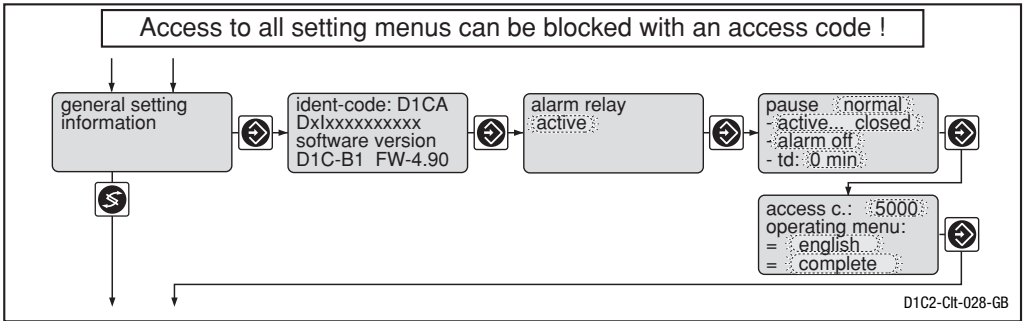

	Initial value	Possible values			Remarks
		Increment	Lower value	Upper value	
Alarm relay	active	active not active			
Pause	normal	normal hold			
Control input pause	active closed	active closed active open			
Pause alarm	alarm off	alarm off alarm on			Alarm relay can be activated by pause contact.
td	0 min	1 min	0 min	60 min	
Access code	5000	1	1	9999	
Language	as per identity code	German English French Italian Dutch Spanish Portuguese Czech Japanese (as per identity code)			
Operating menu	complete	restricted complete			

Complete Operating Menu / Description

Standard Pause

If the pause-switch is off, the DULCOMETER® D1C sets the operating outputs to “0” for as long as the pause-switch is off or for a set time-delay t_d (if t_d is set to > 0 min). Whilst the pause-switch is off, the D1C establishes the P-proportion in the background.

With PID-control (Identity code characteristics “control characteristic” = 2): the I-proportion is stored when the pause is switched off (I-proportion then usually only present if $T_i > 0$ has been selected in the “Control setting?” setting menu).

Exception: the standard signal outputs mA for the measured value or correction value are not affected by the pause.

After pause is activated the operating outputs remain at “0” for the length of the time-delay t_d . The time-delay t_d must be set up in such a way that, in this time e.g. sample water (process-specific current concentration) flows to the sensor.

With PID-control (Identity code characteristics “control characteristic” = 2): The control variable output resulting from the pause and the expiry of the time-delay t_d is reconciled jointly with the current P-component and (if T_i is set > 0) with the stored I-component.

Pause Hold

If the pause-switch is off, the DULCOMETER® D1C freezes the operating output at the most recent value for as long as the pause-switch is off or for a set time-delay t_d (if t_d is set to > 0 min). Whilst the pause-switch is off, the D1C establishes the P-proportion in the background.

With PID-control (Identity code characteristics “control characteristic” = 2):

Even the mA standard signal outputs for measured value or correction value are frozen.

After pause is activated the operating outputs remain frozen for the length of the time delay t_d . The time delay t_d must be set up in such a way that, in this time e.g. sample water (process-specific current concentration) flows to the sensor.

With PID-control (Identity code characteristics “control characteristic” = 2): The control variable output resulting from the pause and the expiry of the time-delay t_d is reconciled jointly with the current P-proportion and (if T_i is set > 0) with the newly established I-proportion.

EC Declaration of Conformity

We,

**ProMinent Dosiertechnik GmbH
Im Schuhmachergewann 5 - 11
D - 69123 Heidelberg**

hereby declare that, on the basis of its functional concept and design and in the version brought into circulation by us, the product specified in the following complies with the relevant, fundamental safety and health stipulations laid down by EC directives.

Any modification to the product not approved by us will invalidate this declaration.

Product description : ***Measurement and control system, DULCOMETER***

Product type : ***D1C / D2C***

Serial number : ***see type identification plate on device***

Relevant EC regulations : ***EC - low voltage directive (73/23/EEC)
EC - EMC - directive 89/336/EEC subsequently 92/31/EEC***

Harmonized standards used,
in particular : ***EN 60335-1, EN 61010-1/2, EN 60204-1
EN 50081-1/2, 50082-1, EN 55014-1/2
EN 61000-3-2/3, EN 61000-6-2***

National standards and other
technical specifications used,
in particular :

Date/manufacturer's signature :

11th December 2000

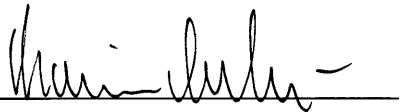

The undersigned :

Dr. Rainer V. Dulger, Executive Vice President R&D and Production

10 Fehler / Hinweise / Fehlerbehebung

Fault	Fault text	Symbol	Effect on metering	Effect on control	Alarm with acknowledgement	Remarks	Remedy
Measured value Checkout time measured value exceeded	Check <i>Cl</i> probe	€	Basic load	Stop	Yes	Function defeatable	Check function of probe
	Signal exceeded/drops below value	€	Basic load	Stop	Yes	Signal <3.0 ±0.2 mA or >23 ±0.2 mA	Check probe, transducer and cable connection
Calibration probe with error	Check <i>Cl</i> calibration	€	Basic load	Stop	No	Metering continues in case of error with unstable measured values	Check probe, replace if necessary, recalibrate if necessary
Feed forward control Signal drops below value multiplicative Signal exceeded	<i>feedfwd</i> , < 4 mA	€	Basic load		Yes	Signal <4.0 ±0.2 mA or >23 ±0.2 mA	Check probe, transducer and cable connection
	<i>feedfwd</i> > 23 mA	€	Basic load		Yes	Value last valid is used	
Limit transgression after checkout time limit value	<i>Cl</i> limit value 1 <i>Cl</i> limit value 2	€			Yes	Function defeatable	Define cause, reset values if necessary
Servomotor Position not reached	<i>Servomotor</i> defective	€			Yes	Servomotor closes	Check servomotor
Electronics error	System error	€	Stop	Stop	Yes	Elektronik data defective	Call in service

Operation	Note text	Symbol	Effect		Alarm with acknowledgement	Remarks	Remedy
			on metering	on control			
Pause contact	Pause	€	Stop	Stop	No	No further fault check	-
	Pause/Hold	€		PI-part frozen			
Stop button	Stop	€	Stop	Stop	No	Relay drops out	-
During calibration probe			Basic load	Stop in complete operating menu	No	No error processing of measured variable	-
Probe slope too low	<i>Slope Cl</i> low	€	Basic load	Stop	No	25% > probe of slope > 300% norm slope	Check probe, replace if necessary
Probe slope too high	<i>Slope Cl</i> high	€					
DPD-value <2 % measuring range	<i>DPD</i> too low					< 2 % from meas. range	
Zero point	<i>Zero point</i> low <i>Zero point</i> high	€	Basic load	Stop	No	Signal < 3 mA Signal > 5 mA (for <i>CLT1-mA-2</i> ppm) Signal > 6 mA (for <i>CLT1-mA-0.5</i> ppm)	Check probe/cable Repeat calibration in chloride-free water
During servomotor setting Position feed back wrong Upper position <40 % max. value Lower position >30 % range	<i>Direction</i> check <i>Final</i> value small <i>Final</i> value big					Without correct adjustment the last valid values are still used	Check connection of relay, potentiometer Adjust the operation region of the servomotor correctly

©2003 ProMinent Dosiertechnik GmbH · 69123 Heidelberg · Germany

Operating Instructions DULCOMETER® D1C, Part 2/I, Issue 09/03

Subject to modifications · Printed in Germany

ProMinent Dosiertechnik GmbH · Im Schuhmachergewann 5-11 · 69123 Heidelberg · Germany

Postfach 101760 · 69007 Heidelberg

Phone: +49 (6221) 842-0 · Fax: 842-419

info@prominent.de · www.prominent.de