



Operating Instructions

DULCOMETER® D1C

Part 2: Adjustment and Operation,
Measured Variable Chlorine

D1C2-CI-001-GB

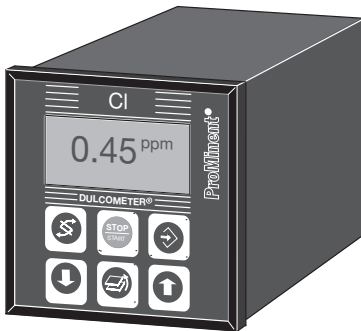

Type D



Type W

D1C A

Please enter the identity code of your device here!

**Please completely read through operating instructions! · Do not discard!
The warranty shall be invalidated by damage caused by operating errors!**

2 Contents / General User Information

	Page
1 Device Identification / Identity Code	2
2 General User Information	3
3 Device Overview / Controls	4
4 Functional Description	5
5 Display Symbols	6
6 Operation	7
7 Restricted Operating Menu	8
Layout	8
Description	9
8 Complete Operating Menu	14
Overview	14
Description	15
9 Fault/Remarks/Troubleshooting	29

General User Information

These operating instructions describe the technical data and function of the DULCOMETER® D1C controller, provide detailed safety information and are divided into clear steps.



IMPORTANT



- ***Please observe the parts of these operating instructions applicable to your particular version! This is indicated in the Section “Device Identification / Identity Code”!***
- ***Correct measuring and dosing is only possible in the case of impeccable operation of the sensor. The sensor has to be calibrated / checked regularly!***

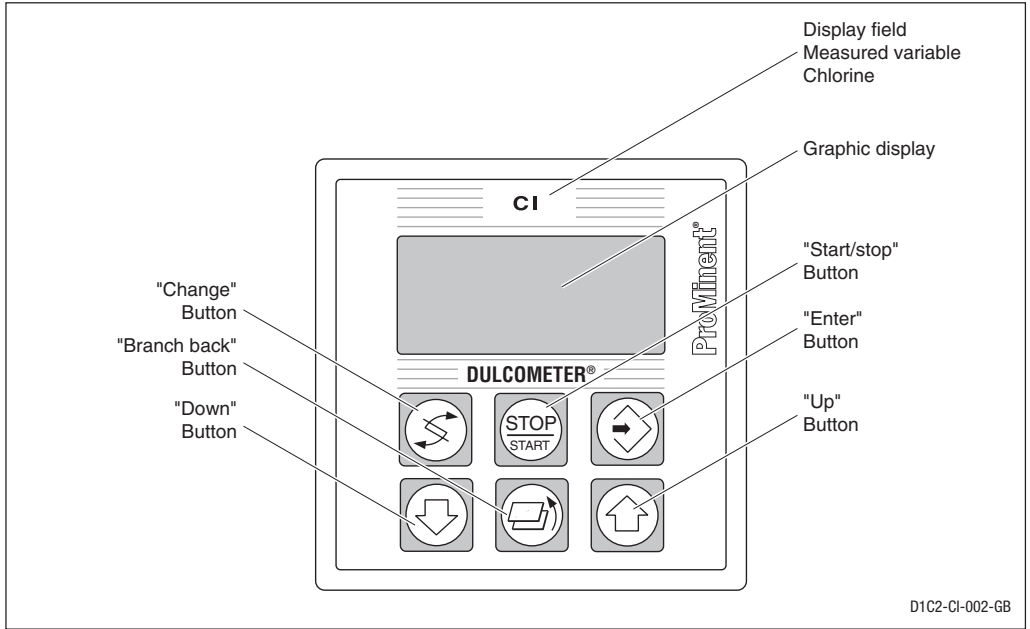

NOTE

A form “Documentation of controller settings type D1C” is available under www.prominent.com/documentation_D1C for the purpose of documenting the controller settings.

3 Device Overview / Controls



	<p>CHANGE button</p> <p>To change over within a menu level and to change from one variable to another within a menu point.</p>
	<p>START/STOP button</p> <p>Start/stop of control and metering function.</p>
	<p>ENTER button</p> <p>To accept, confirm or save a displayed value or status. For alarm acknowledgement.</p>

	<p>UP button</p> <p>To increase a displayed numerical value and to change variables (flashing display)</p>
	<p>BRANCH BACK button</p> <p>Back to permanent display or to start of relevant setting menu.</p>
	<p>DOWN button</p> <p>To decrease a displayed numerical value and to change variables (flashing display).</p>

4 Functional Description

NOTE

Please refer to the description of the complete operating menu in Section 8 for a detailed description of the individual characteristics of the DULCOMETER® D1C controller!

4.1 Operating Menu

The D1C controller permits settings to be made in two different menus. All values are preset and can be changed in the **complete operating menu**.

The controller is delivered with a **restricted operating menu** so that the D1C controller can be used effectively in many applications from the very onset. If adaptations prove to be necessary, all relevant parameters can then be accessed by switching over to the complete operating menu (see “General settings”).

4.2 Access Code

Access to the setting menu can be prevented by setting up an access code. The D1C controller is supplied with the access code 5000 which permits free access to the setting menu. The calibration menu remains freely accessible even if access to the setting menu is blocked by the code.

4.3 Control

The D1C can operate as a proportional controller or as a PID controller - dependent on the device version (see identity code) and the setting.

The controlled variable is recalculated once a second. Control procedures which required rapid correction of setpoint deviations (less than approx. 30 seconds) cannot be processed with this controller. The cycle times must be taken into consideration when activating solenoid valves (pulse length) in the same way as their running times when activating servomotors (3-point).

Via the control input pause, the control function (selection of controlled variable) can be switched off. The calculation of the controlled variable starts again after cessation of “pause”.

4.4 Feed Forward Control

The D1C controller can process a signal of a feed forward control. Depending on the device version (see identity code) and the setting, this signal can be obtained in any form of a 0–20 mA or 4–20 mA signal or as a digital contact signal with the maximum frequencies 10 Hz or 500 Hz.

During start-up, the zero point has to be checked. The multiplicative feed forward control is not designed for switching off permanently the actuating variable (signal ≈ 0).

This signal can be used, for example, for flow-proportional metering (multiplicative effect) or feed forward-dependent basic load metering (additive effect). The result of control variable calculation from the proportional or PID control is multiplied by or added to the feed forward signal. A multiplicative feed forward variable at the level of the set rated value carries over the calculated control variable unchanged into the control variable:

$$\text{Control variable} = \text{Feed forward variable} / \text{rated value} \times \text{calculated control variable}$$

An additive feed forward variable at the level of the rated value results in maximum control variable:

$$\text{Control variable (max. 100 \%)} = \text{Feed forward variable} / \text{rated value} \times \text{max. control variable} + \text{calculated control variable}$$

4.5 Error Messages

Error messages and information are indicated in the bottom line in the permanent display 1. Errors to be acknowledged (acknowledgement switches off the alarm relay) are indicated by the “E”. Errors/notes which still apply after acknowledgement are indicated alternately. During correction variable processing (temperature for correction of pH-value), the value is indicated in the same line as the error/note. Faults which are rectified of their own accord due to changed operating situations are removed from the permanent display without the need for acknowledgement.

5 Display Symbols

The display of the DULCOMETER® D1C controller uses the following symbols:

Description	Comment	Symbol
Limit value transgression Relay 1, upper	Symbol left	↑
Relay 1, lower	Symbol left	↓
Relay 2, upper	Symbol right	↑
Relay 2, lower	Symbol right	↓
Metering pump 1 (chlorine) Control off	Symbol left	■
Control on	Symbol left	□
Metering pump 2 (dechlorine) Control off	Symbol right	■
Control on	Symbol right	□
Solenoid valve 1 (chlorine) Control off	Symbol left	▲
Control on	Symbol left	△
Solenoid valve 2 (dechlorine) Control off	Symbol right	▲
Control on	Symbol right	△
Servomotor Control, open relay		▲ △
Control, close relay		△ ▲
Without control		▲ ▲
Position feedback	Thickness of bar increases from left to right during opening	▬
Stop button pressed		O
Manual metering		M
Fault		ε

6 Operation

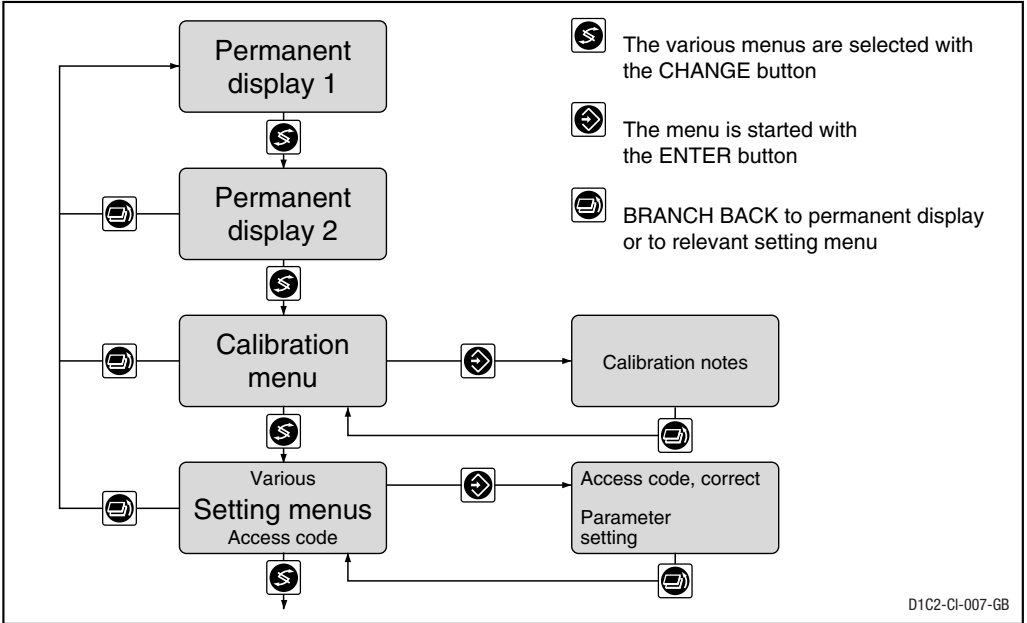

NOTE

Access to the setting menus can be barred with the access code!

The number and scope of setting menus is dependent on the device version!

If the access code is selected correctly in a setting menu, then the following setting menus are also accessible!

If within a period of 10 minutes no button is pressed, the unit automatically branches back from the calibrating menu or a setting menu to the permanent display 1.

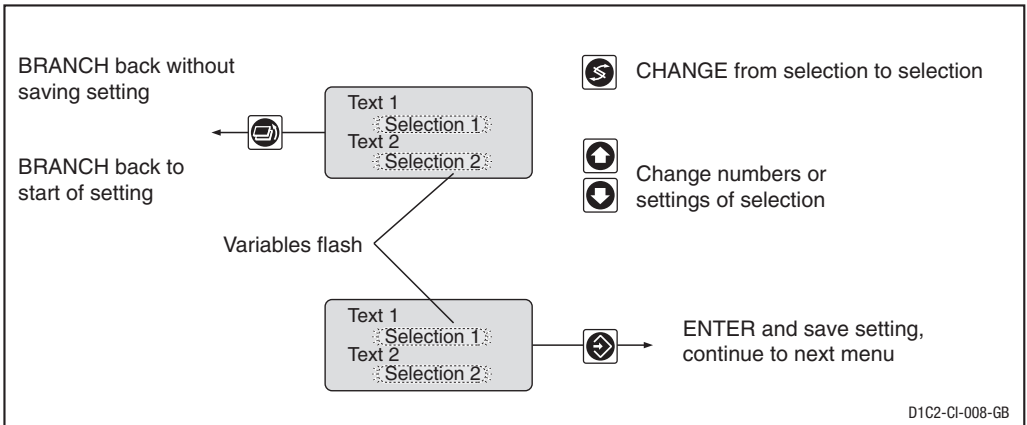

7 Restricted Operating Menu / Layout

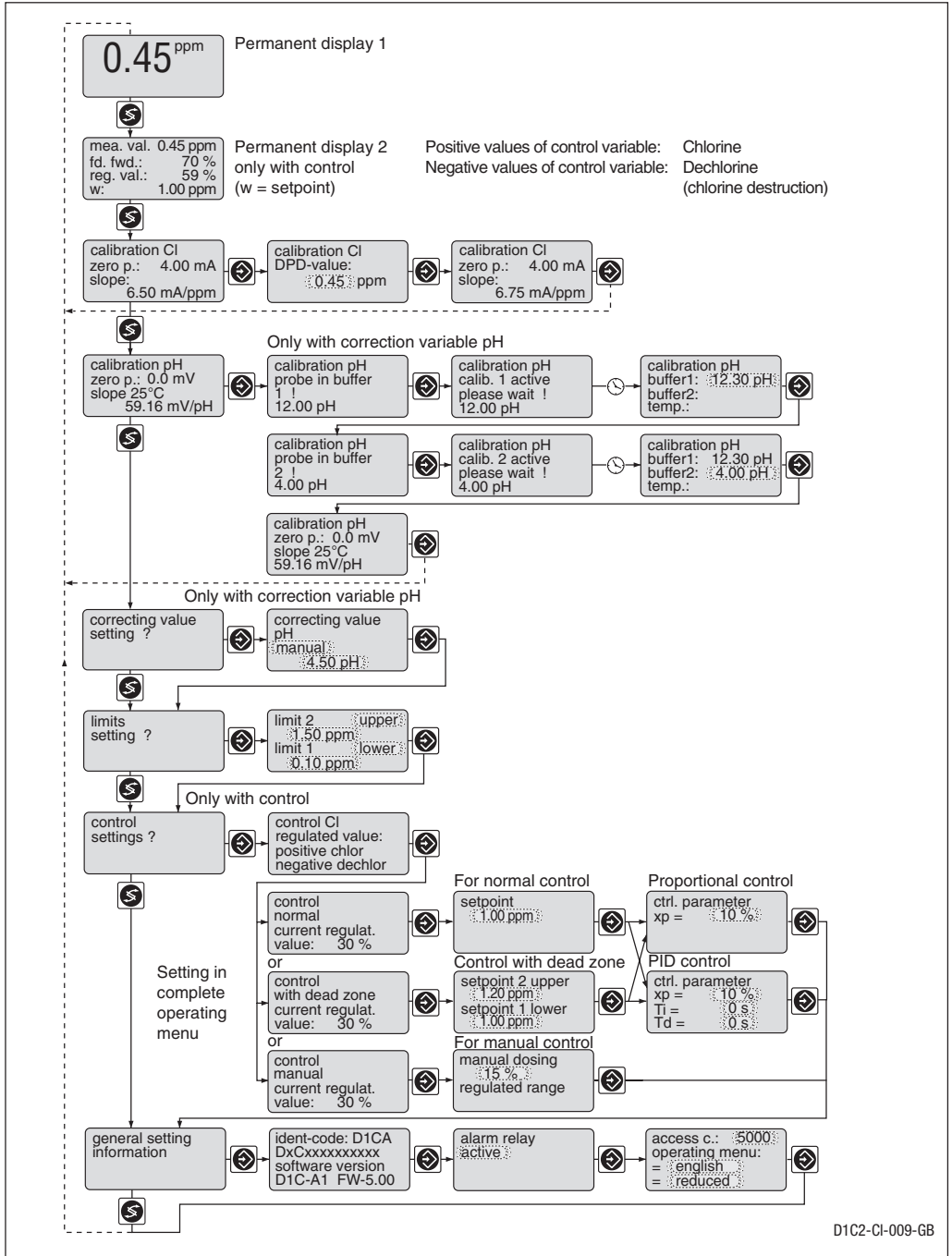

Restricted Operating Menu / Description

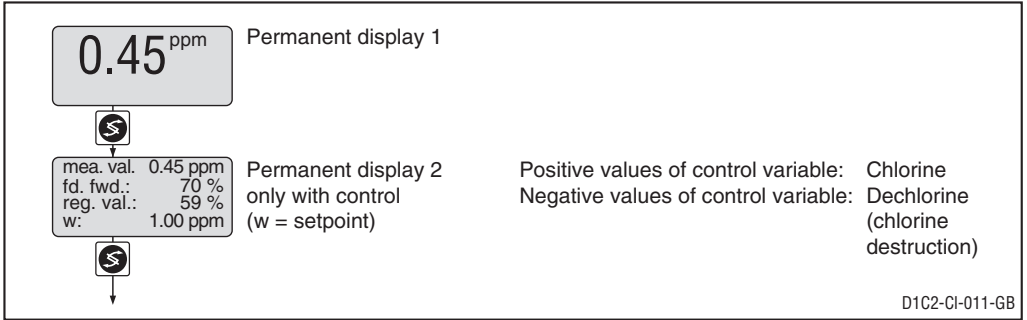

Calibration of the Chlorine sensor

During the calibration, the D1C sets the controller outputs to “0”. Exception: If a base load or manual controller output was set, these are maintained during the calibration. The standard signal outputs mA (measured value or correction value) are frozen. The measured value registered during the start of the calibration is proposed as the DPD value; this value is adjustable (arrow keys!). Calibration is only possible if the DPD value is $\geq 2\%$ of the measuring range. On successful completion of calibration, all error checks which refer to the measured value are restarted.



IMPORTANT

The measuring range of the chlorine sensor must correspond to the adjusted measuring range (factory setting: 0–2 ppm). A change of the measuring range (see page 17) must be done before calibration!

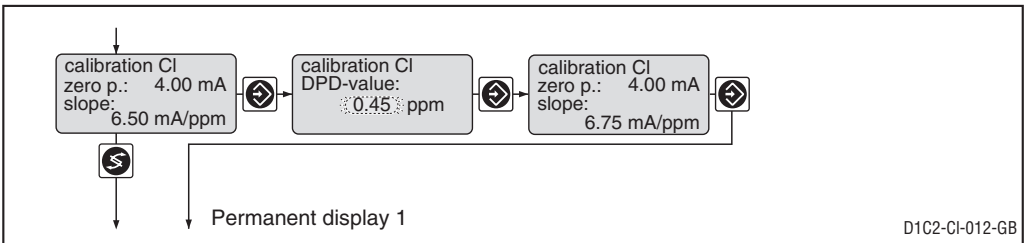

	Initial value	Possible values			Remarks
	Measured value	Increment	Lower value	Upper value	
	Measured value	0.01 ppm	0 ppm	100 ppm	

Error message	Condition	Effect
Calibration CI not possible! Sensor slope too low ($< 25\%$ of norm slope)	CI slope too low	Calibrate again
Calibration CI not possible! Sensor slope too high ($> 300\%$ of norm slope)	CI slope too high	Calibrate again
DPD value too low! DPD $> x.xx$ ppm	DPD $< 2\%$ of measuring range	Calibrate again after adding chorine

Restricted Operating Menu / Description

Calibrating the pH sensor (only possible with correcting variable pH)

The pH sensor is calibrated with the aid of two-point calibration (zero point/slope). Buffer self-detection at pH 7 (zero point calibration) and at pH 4 (calibration of slope). The measured pH value of the buffer is proposed as the buffer value and can be changed manually (arrow keys). The control is stopped during calibration and reduced to the set basic load. The measured value is frozen. The errors relating to the corresponding measured variable are reset after successful calibration. The current data of the pH sensor (zero point and slope) are displayed.

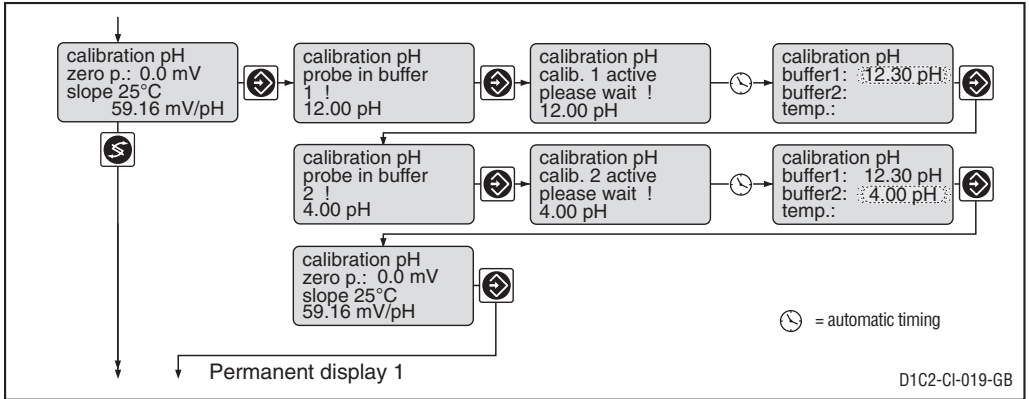

	Initial value	Possible values			Remarks
		Increment	Lower value	Upper value	
Buffer values	Rounded-off whole number measured value	pH 0.01	pH -2	pH 16	<p>Error messages when both buffers too close (<2 pH values).</p> <p>In order to operate perfectly, the pH sensor must be checked and calibrated regularly (weekly), since deviations of ± 0.1 pH may cause errors of measurement.</p> <p>Further more, when using a CLE sensor, a slope calibration adjustment of the chlorine sensor should always be done after a pH calibration.</p>

- IMPORTANT**
- pH correction is not possible if there are oxidating substances in the sample water! When a CLE measuring sensor is used:**
- The temperature must be between 10 °C and 15 °C
 - The pH value must be between 5 and 8
 - The corrective sensor current is limited to 25 mA

Restricted Operating Menu / Description

Error message	Condition	Comment
Buffer distance too small	$\Delta\text{Buffer} < \text{pH } 2$	During calibration procedure: Recalibrate buffer 2!
Zero point low Zero point high Slope low Slope high Measured value pH unstable Measured value °C unstable	< -60 mV < +60 mV <40 mV/pH >65 mV/pH $\Delta U > 3 \text{ mV to } t > 60 \text{ s}$	Return to permanent display: Basic metering load " " " Standard metering

pH correction

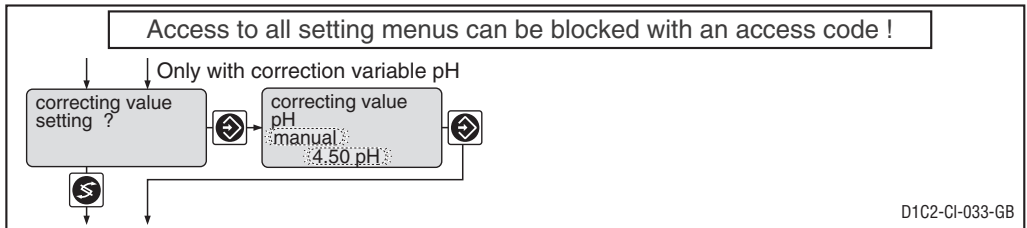

	Initial value	Possible values Increment	Lower value	Upper value	Remarks
Correction value	off manual automatic	off			When selecting manual pH correction, the pH value must not change more than $\pm 0.1 \text{ pH units}$

Limits

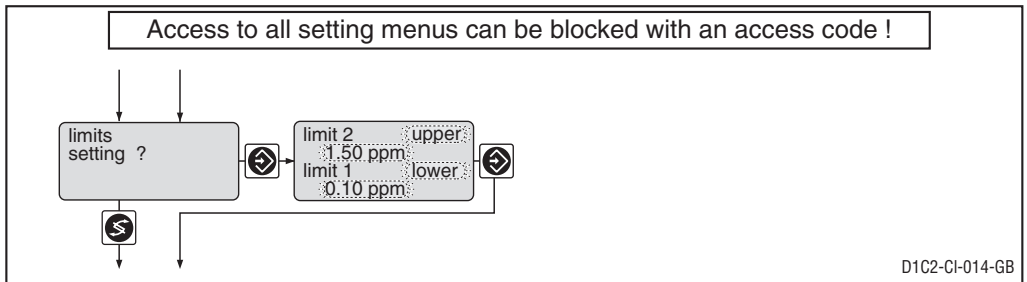

	Initial value	Possible values Increment	Lower value	Upper value	Remarks
Type of limit transgression	Limit 1: Limit 2:	upper lower off*			Limit transgression when exceeding or dropping below value
Limit value	Limit 1: Limit 2:	0.01 ppm 0.01 ppm	0.00 ppm 0.00 ppm	100.00 ppm 100.00 ppm	*only with limit relay

Restricted Operating Menu / Description

Control

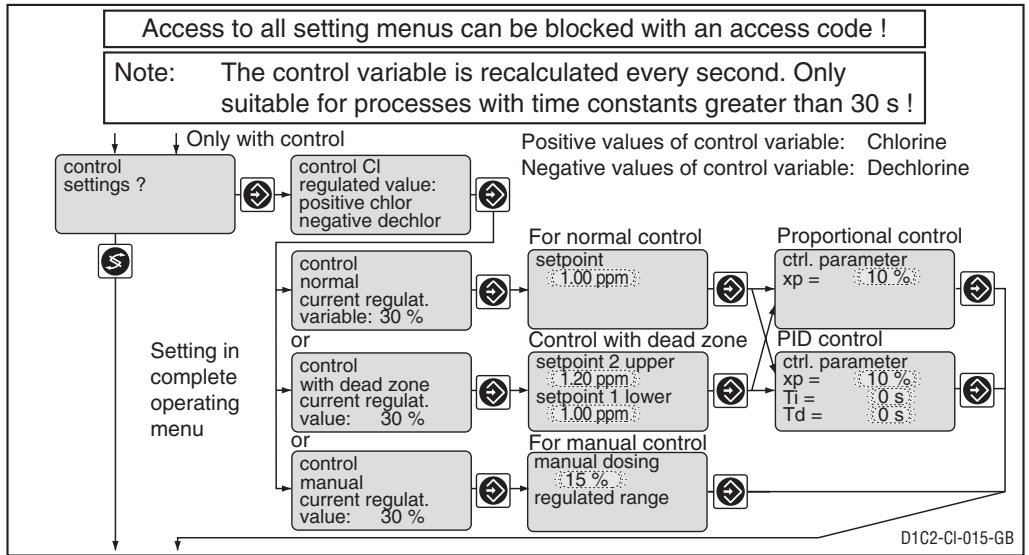

	Initial value	Possible values			Remarks
		Increment	Lower value	Upper value	
Setpoint	1.00 ppm	0.01 ppm	lower limit measuring range	upper limit measuring range	2 setpoints necessary for control with dead zone. Setpoint 1 < setpoint 2 See page 17 for setting measuring range
Control parameter xp	10 %	1 %	1 %	500 %	xp referred to measuring range
Control parameter Ti	off	1 s	1 s	9999 s	Function off = 0 s
Control parameter Td	off	1 s	1 s	2500 s	Function off = 0 s
Manual metering	0 %	1 %	-100 %	+100 %	

Abbreviations for control variables:

x_p = 100 %/Kp (inverse proportional coefficient)

T_i = I controller integration time [s]

T_d = D controller differential time [s]

Restricted Operating Menu / Description

General Settings

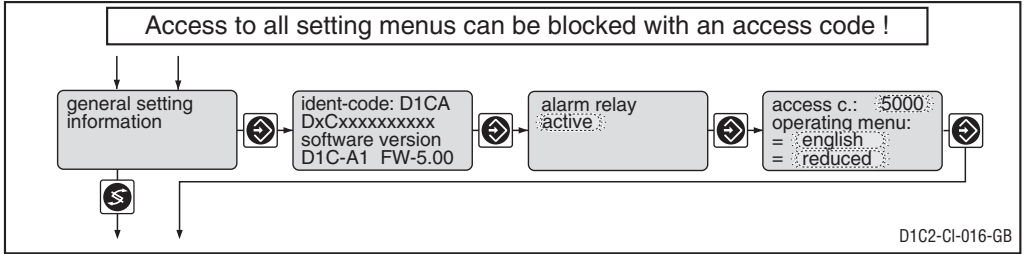

	Initial value	Possible values		Remarks
		Increment	Lower value	
Alarm relay	active	active not active		
Access code	5000	1	1	9999
Language	as per identity code	as per identity code		
Operating menu	restricted	restricted complete		

Access Code

Access to the setting menu can be prevented by setting up an access code. The DULCOMETER® D1C controller is supplied with the access code 5000 which permits free access to the setting menu. The calibration menu remains freely accessible even if access to the setting menu is blocked by the code.

8 Complete Operating Menu / Overview

All parameters of the controller can be set in the complete operating menu (access see previous page). The following overview shows the settings which can be selected:

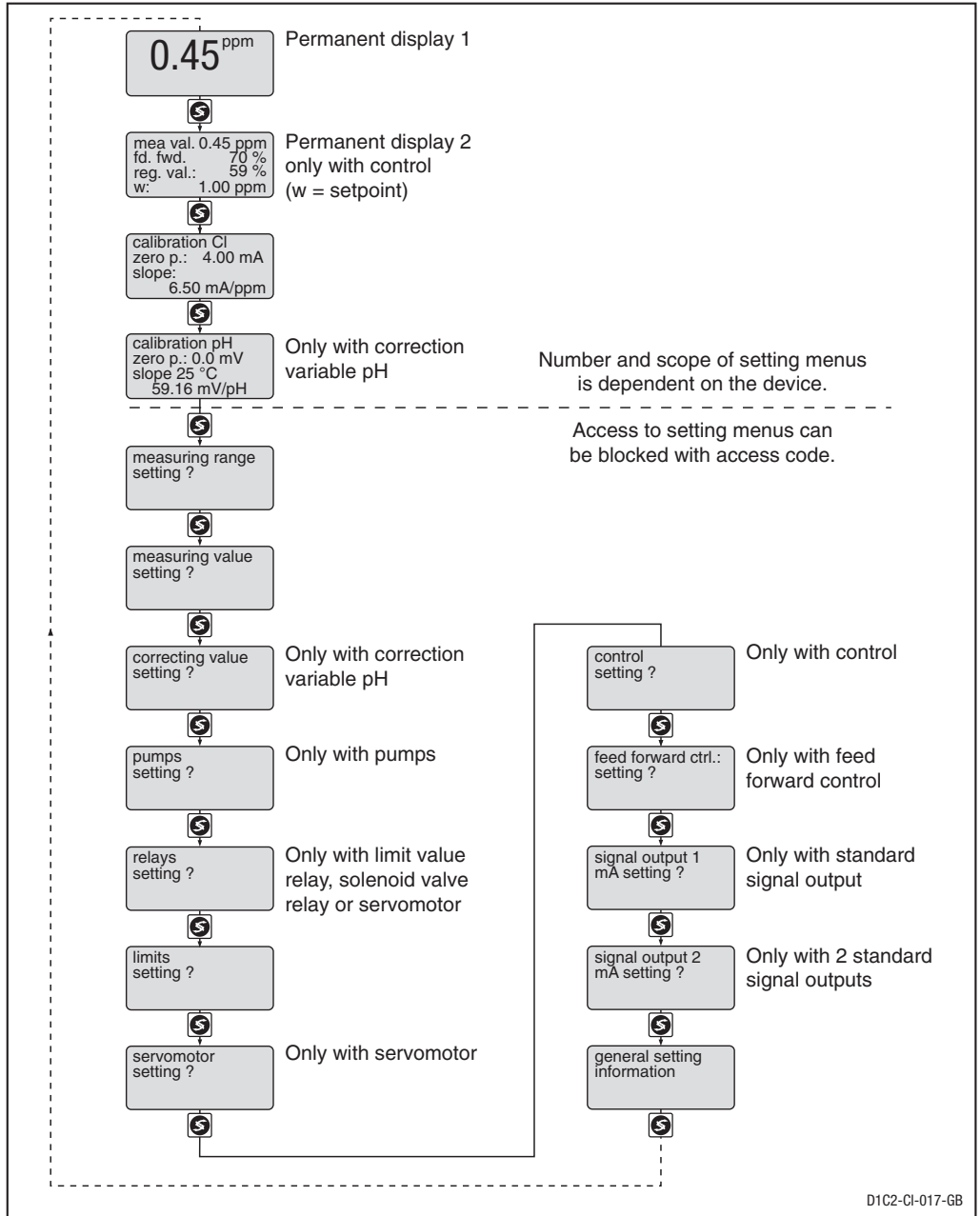

D1C2-CI-017-GB

Complete Operating Menu / Description

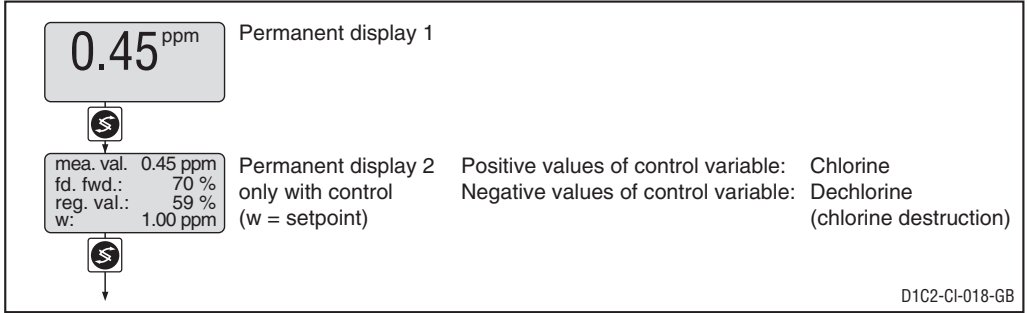

Calibration of the Chlorine sensor (Zero point and slope)

During the calibration, the D1C sets the controller outputs to “0”. Exception: If a base load or manual controller output was set, these are maintained during the calibration. The standard signal outputs mA (measured value or correction value) are frozen. The measured value frozen at the start of calibration is offered as the DPD value; this value is adjustable (arrow keys!). Calibration is only possible if the DPD value is $\geq 2\%$ of the measurement range. Once calibration has been successfully completed, all fault tracing procedures which refer to the measured value are restarted.

Zero point calibration must be carried out under real conditions in water free of chlorine dioxide. Calibration is normally only necessary for the measuring range 0 – 0.5 ppm when measuring at the lower limit of the measuring range.



IMPORTANT

The measuring range of the sensor must agree with the set measuring range (factory setting: 0-2 ppm). The measuring range must be reset prior to calibration (see page 17).

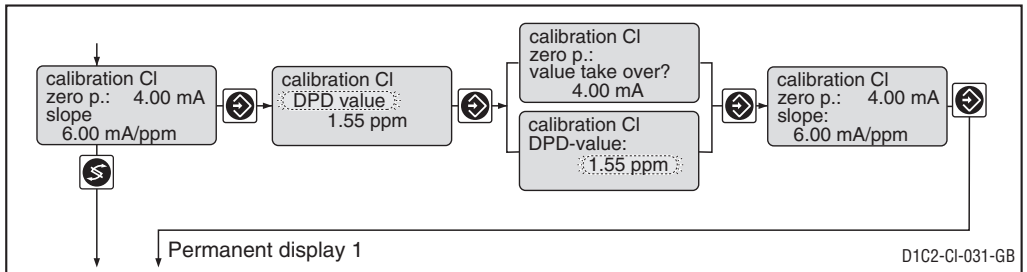

	Initial value	Possible values			Remarks
		Increment	Lower value	Upper value	
	Measured value	0.01 ppm	0 ppm	100 ppm	

Error message	Condition	Comment
Calibration CI not possible! Zero point too low	Zero point < 3 mA	Repeat calibration in sample water without chlorine!
Calibration CI not possible! Zero point too high	Zero point > 5 mA	Repeat calibration in sample water without chlorine!

Complete Operating Menu / Description

Error message	Condition	Effect
Calibration CI not possible! Slope low	Slope CI too low (<25 % of norm slope)	Calibrate again!
Calibration CI not possible! Slope high	Slope CI too high (>300 % of norm slope)	Calibrate again!
DPD value too low DPD > x.xx ppm	DPD <2 % measuring range	Calibrate again after adding chlorine

Calibrating the pH sensor (only possible with correcting variable pH)

The pH sensor is calibrated with the aid of two-point calibration (zero point/slope). Buffer self-detection at pH 7 (zero point calibration) and at pH 4 (calibration of slope). The measured pH value of the buffer is proposed as the buffer value and can be changed manually (arrow keys). The control is stopped during calibration and reduced to the set basic load. The measured value is frozen. The errors relating to the corresponding measured variable are reset after successful calibration. The current data of the pH sensor (zero point and slope) are displayed.

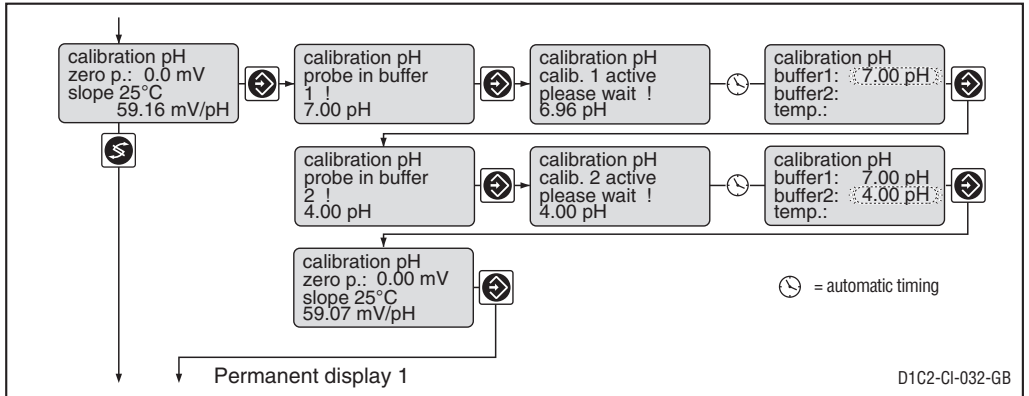

	Initial value	Possible values			Remarks
		Increment	Lower value	Upper value	
Buffer values	Rounded off whole number measured value	pH 0.01	pH -2	pH 16	<p>Error messages when both buffers too close (<2 pH values).</p> <p>In order to operate perfectly, the pH sensor must be checked and calibrated regularly (weekly), since deviations of ± 0.1 pH may cause errors of measurement. Furthermore, when using a CLE sensor, a slope calibration adjustment of the chlorine sensor should always be done after a pH calibration.</p>

Complete Operating Menu / Description

Error message	Condition	Comment
Buffer distance too small	$\Delta\text{Buffer} < \text{pH } 2$	During calibration procedure: Recalibrate buffer 2!
Zero point low	$< -60 \text{ mV}$	Return to permanent display: Basic metering load
Zero point high	$< +60 \text{ mV}$	"
Slope low	$< 45 \text{ mV/pH}$	"
Slope high	$> 65 \text{ mV/pH}$	"
Measured value pH unstable		"
Measured value °C unstable		"

Measuring range

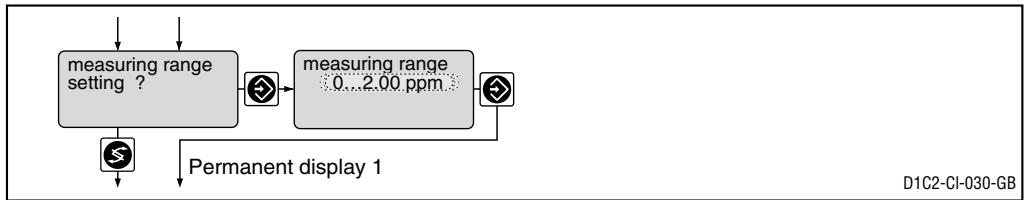

IMPORTANT

The chlorine sensor must be recalibrated and the settings checked in all menus after changing the range allocation!

	Initial value	Possible values	Lower value	Upper value	Remarks
		Increment			
Measuring range	0...2 ppm	0...0.5 ppm 0...2 ppm 0...5 ppm 0...10 ppm 0...20 ppm 0...50 ppm 0...100 ppm			

Measured value

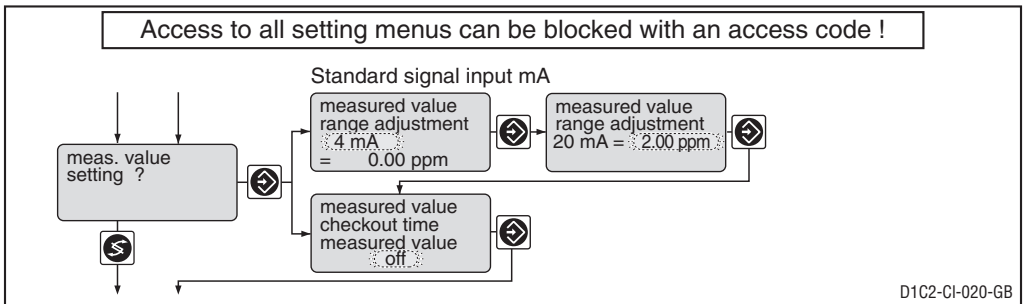

IMPORTANT

The chlorine sensor must be recalibrated and the settings checked in all menus after changing the range allocation!

Complete Operating Menu / Description

	Initial value	Possible values			Remarks
		Increment	Lower value	Upper value	
Standard signal input lower signal limit	4 mA	0 mA 4 mA			Constant measurement signal results in message and alarm. Function off = 0 s
Allocated measured value					
lower	0 ppm				
upper	2 ppm	0.01 ppm	0.00 ppm	100.00 ppm	
Checkout time	off	1 s	1 s	9999 s	

Measured value checkout time

! **IMPORTANT**
This function may not be activated for applications in which it can be assumed that the measured value will not change.

This function tests whether the measured value varies from that of the sensor (at the measured value input) within the “Measured value checkout time”. It is assumed that it will do so for an intact sensor. If the measuring value does not change during this checkout time, the DULCOMETER® D1C sets the control variable to “0” and the alarm relay drops out. The LCD display shows e.g. the message “Check CI probe”.

Correction value pH

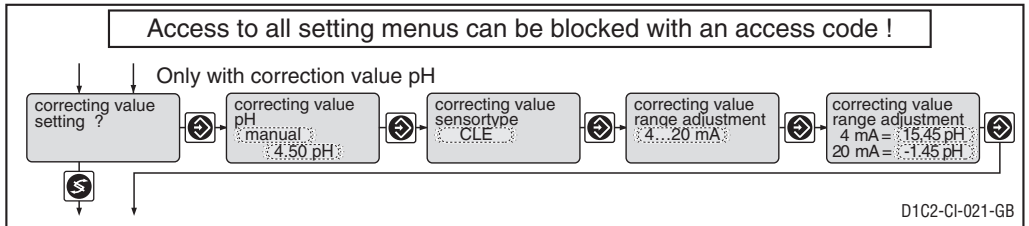

	Initial value	Possible values			Remarks
		Increment	Lower value	Upper value	
Correcting value	off manual automatic	off			A pH change < pH 0.1 must remain at “manual”
Type of sensor	CLE	CLE CGE/CTE			
Standard signal input	4 mA	4 mA			
Lower signal limit		0 mA			
Scheduled measuring range	pH 15.45 ... pH -1.45	pH 0.01	pH -2	pH 16	

Complete Operating Menu / Description

Pumps

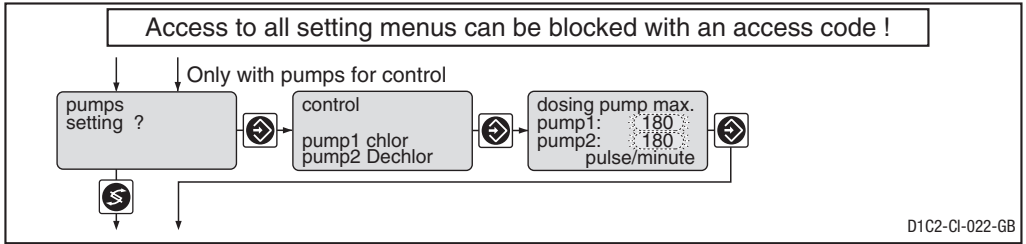

	Initial value	Possible values			Remarks
		Increment	Lower value	Upper value	
Max. stroke/minute of pumps 1 and 2	180	1	1	500	off = 0 strokes/min

Relay for power activation

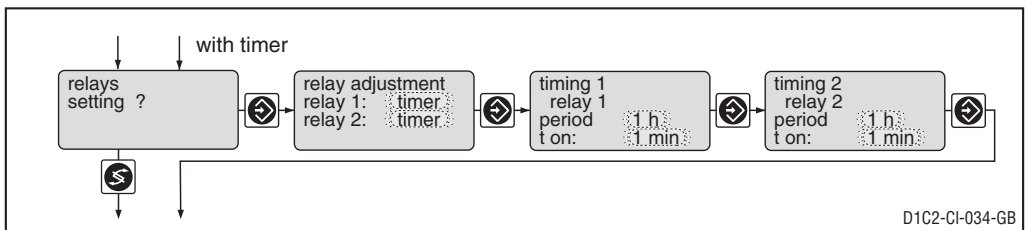
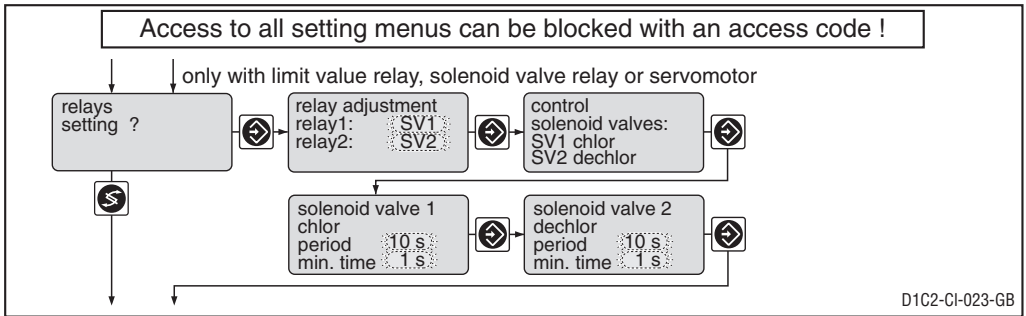

	Initial value	Possible values			Remarks
		Increment	Lower value	Upper value	
Relay adjustment	as per identity code	Motor Solenoid valve (SV1, SV2) Limit value (Limit 1/2)* Actuator 1,2 Timer 1, 2 Servomotor off			* In the case of "Limit value" - relays remain active even in the event of an error. only with servomotor

Complete Operating Menu / Description

	Initial value	Possible values			Remarks
		Increment	Lower value	Upper value	
Period	10 s	1 s	10 s	9999 s	for solenoid valve for solenoid valve Set here the smallest permitted operating factor of the connected device.
min. time	1 s	1 s	1 s	period/2	
Period	off	1 h	1 h / off	240 h	for timer
t on	1 min	1 min	1 min	60 min	for timer

NOTE

The limit value relay can be defined in such a way as to respond as a control element, i.e. if a limit value relay closes a circuit, it opens when a pause contact is activated and/or for a subsequent delay period t_d (if t_d is set to > 0 min in "General settings").

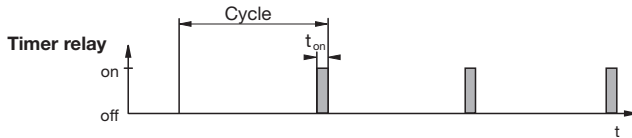

IMPORTANT

The timer will reset in the event of a power failure.

At the end of the (timer) cycle time the DULCOMETER® D1C closes the assigned relay for the duration of "t on" (timer). "Pause" interrupts the timer.

When the clock is shown in the LC display the timer can be reset to the start of the cycle at precisely this point using the enter button.

The % figure in the LC display indicates the progress of the current cycle.

Timer relays may be used, e.g. for shock metering or sensor cleaning.

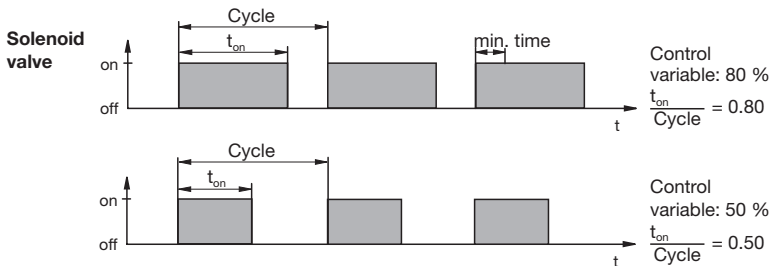

The switching time of the DULCOMETER® D1C (solenoid valve) depends on the control variable and the "min. time" (smallest permitted operating factor of the connected device).

The control variable determines the ratio $t_{on}/cycle$ and thus the switching times (see fig. above).

The "min. time" influences the switching times in two situations:

Complete Operating Menu / Description

a) theoretical switching time < min. time:

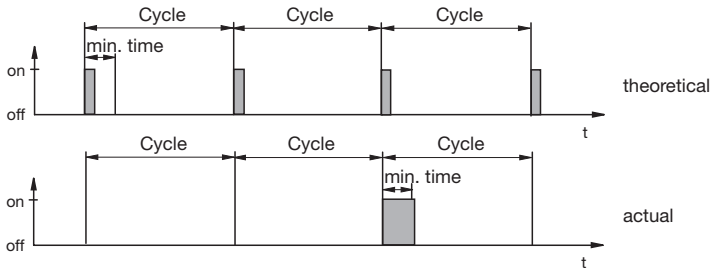

The DULCOMETER® D1C does not switch for a certain number of cycles until the sum of the theoretical switching times exceeds the “min. time”. Then the DULCOMETER® D1C switches for the duration of this total time.

b) theoretical switching time > (cycle - min. time) and calculated switching time < cycle

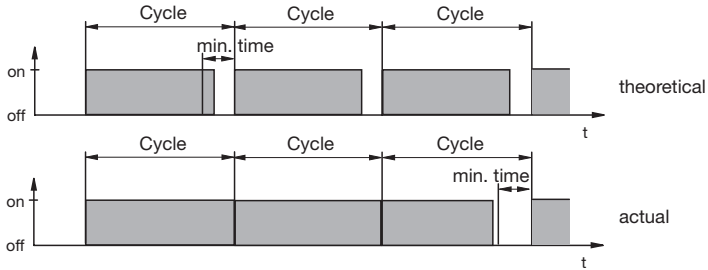

The DULCOMETER® D1C does not deactivate for a certain number of cycles until the differences between cycle and theoretical switching time exceed the “min. time”.

Complete Operating Menu / Description

Limits

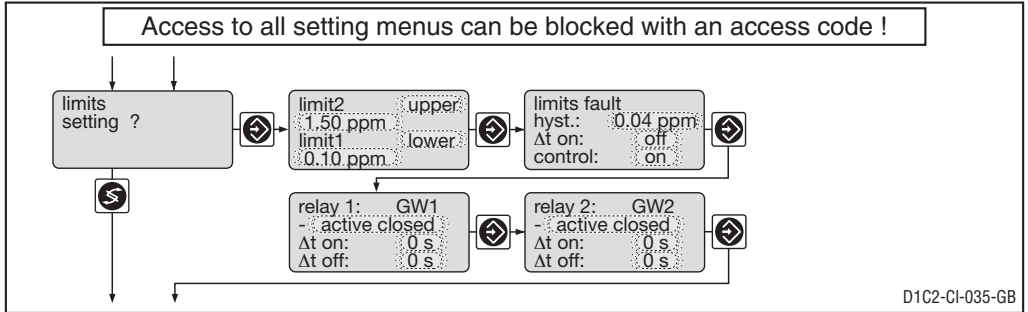

	Initial value	Possible values			Remarks
		Increment	Lower value	Upper value	
Type of limit transgression	Limit 1: lower Limit 2: upper	upper lower off*			Limit transgression when exceeding or dropping below value *only with limit value relay
Limit value	Limit 1: 0.10 ppm Limit 2: 1.50 ppm	0.01 ppm 0.01 ppm	0.00 ppm 0.00 ppm	20.00 ppm 20.00 ppm	
Hysteresis limits	0.04 ppm	0.01 ppm	0.02 ppm	20 ppm	Effective in direction of cancelling limit transgression. Results in message and alarm. off = 0 s: Function switched off, no message, no alarm
Checkout time limits Δt on	off	1 s	1 s	9999 s	
Control	on	on off			Acts as N/O Acts as N/C
Switching direction Limit value 1, Limit value 2	active closed	active closed active open			
Switch-on delay Δt on	0 s	1 s	0 s	9999 s	
Switch-off delay Δt off	0 s	1 s	0 s	9999 s	

If the limit is exceeded for longer than the “Delay time limit values” an error message is given, which must be acknowledged, and the alarm relay circuit drops out. If “Controller” is also set to “off” the control process stops.

Complete Operating Menu / Description

Servomotor

The **operating range** is defined by the total resistance range of the feedback potentiometer. The maximum limit of the range actually used is set by defining the **control range**.



IMPORTANT

- To ensure correct function, the set duration of the stroke position motor should be more than 25 sec for 0...100 % of setting range.
- Stroke adjustment motor actuation must be carried out with the same care as the calibration of a sensor!

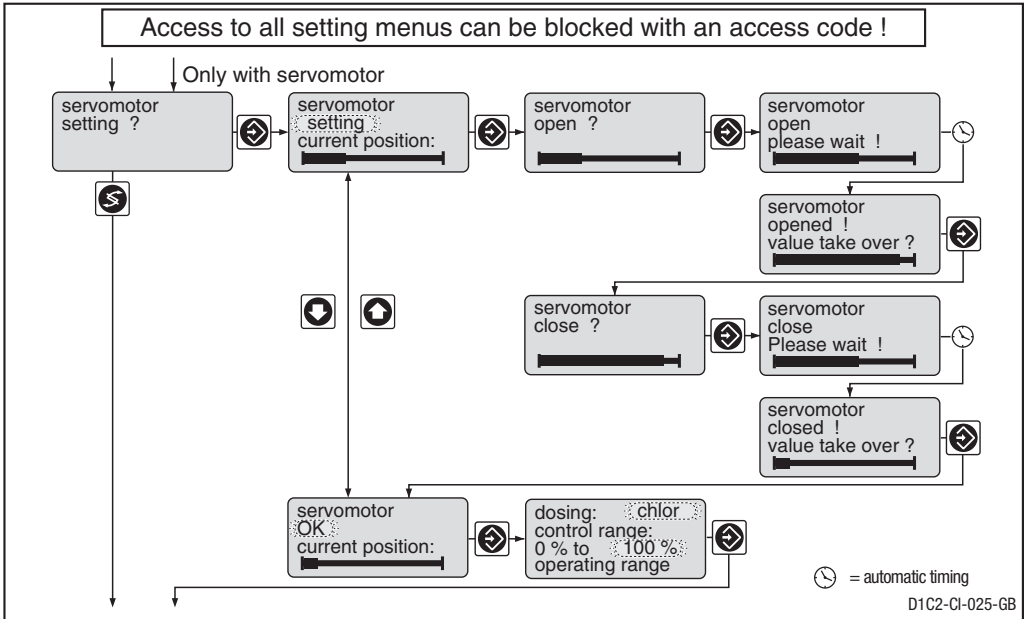

	Initial value	Possible values			Remarks
		Increment	Lower value	Upper value	
Servomotor	Setting	Setting ok off			
Control direction	Chlorine	Chlorine Dechlorine			
Control range	100 %	1 %	10 %	100 %	in % of operating range

NOTE

- When the wide bar is as right as it will go the stroke adjustment motor is fully open.
- The permanent display shows to what degree the motor has opened in % (the greater the percentage, the farther open the stroke adjustment motor).

Complete Operating Menu / Description

Control

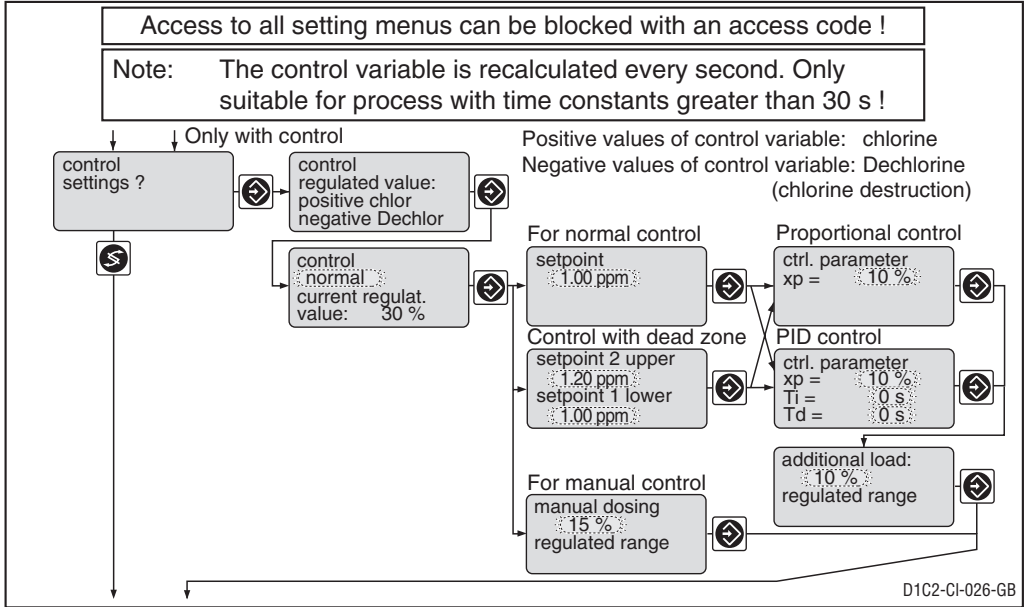

	Initial value	Possible values			Remarks
		Increment	Lower value	Upper value	
Control	normal	normal with dead zone manual			When controlling with dead zone, the feed forward control is not used for measured values within the dead zone.
Setpoint	1.00 ppm	0.01 ppm	Lower measurement range limit	Upper measurement range limit	Measuring unit % Measuring unit mA 2 setpoints necessary for control with dead zone. Setpoint 1 < setpoint 2
Control parameter xp	10 %	1 %	1 %	500 %	xp referred to measuring range
Control parameter Ti	off	1 s	1 s	9999 s	Function off = 0 s
Control parameter Td	off	1 s	1 s	2500 s	Function off = 0 s
Additional load	0 %	1 %	-100 %	+100 %	
Manual metering	0 %	1 %	-100 %	+100 %	

Abbreviations for control variables:

x_p = 100 %/Kp (inverse proportional coefficient)

T_i = I controller integration time [s]

T_d = D controller differential time [s]

Complete Operating Menu / Description

Feed forward control

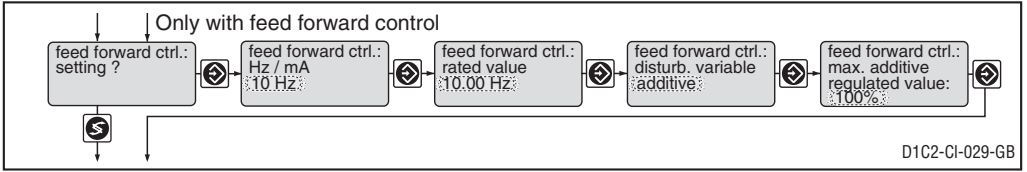

	Initial value	Possible values			Remarks
		Increment	Lower value	Upper value	
Feed forward control (Flow)	as per identity code	None			Signal processing: Signal <0,02 Hz = No flow Signal <0,2 Hz = No flow Signal <0,2 mA = No flow Signal <4,2 mA = No flow Dependent on signal type. Maximum limitation of range used.
	Standard signal	10 Hz			
	4...20 mA	500 Hz			
		0...20 mA			
Feed forward control rated value	10 Hz	0.01 Hz	0.1 Hz	10 Hz	Maximum limitation of range used.
	500 Hz	1 Hz	5 Hz	500 Hz	
	20 mA	0.1 mA	0/4 mA	20 mA	
Feed forward control effect	multiplicative	multiplicative			only with additive feed forward control
Max. add. regulated value	100 %	1 %	-500 %	+500 %	

Standard signal output 1

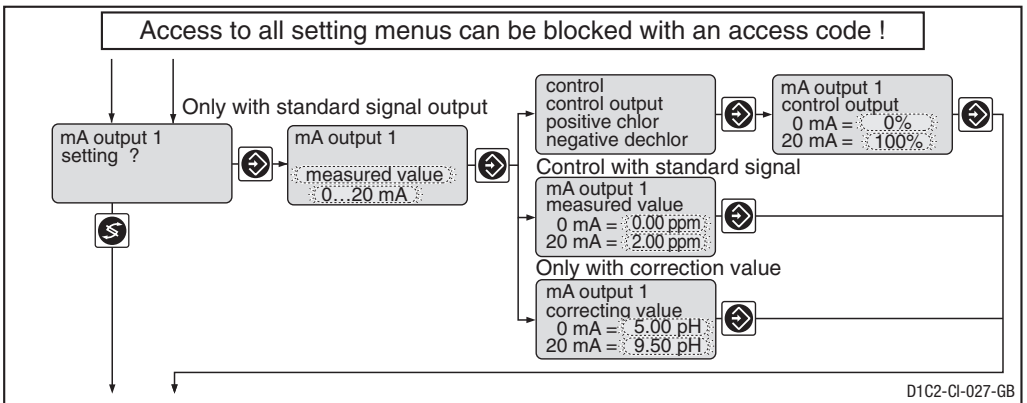

Complete Operating Menu / Description

Standard signal output 2

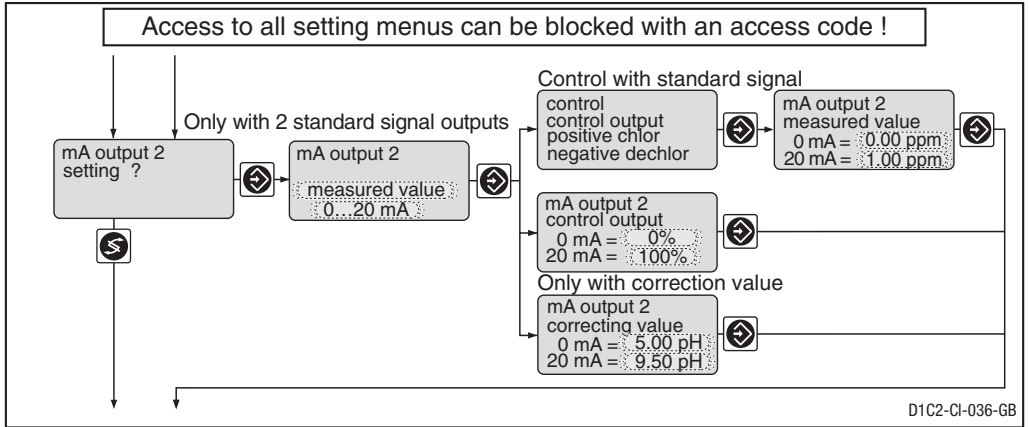

	Initial value	Possible values			Remarks
		Increment	Lower value	Upper value	
Variable allocation	as per identity code	Measured value Control variable Correction value			If control applicable only with correction variable
Output range	0...20 mA	0...20 mA 4...20 mA 3.6/4 -20 mA			Reduction to 3.6 mA when alarm relay switches (not limit-value violation)
Range measured value	Measuring range	0.01 ppm	0 ppm	100 ppm	Minimum range 0.1 ppm
Range control variable	0 %...+100 %	1 %	-100 %	+100 %	Minimum range 1 %
Range correction value	pH 5...9.5	pH 0.01	pH -2	pH 16	

Complete Operating Menu / Description

General setting

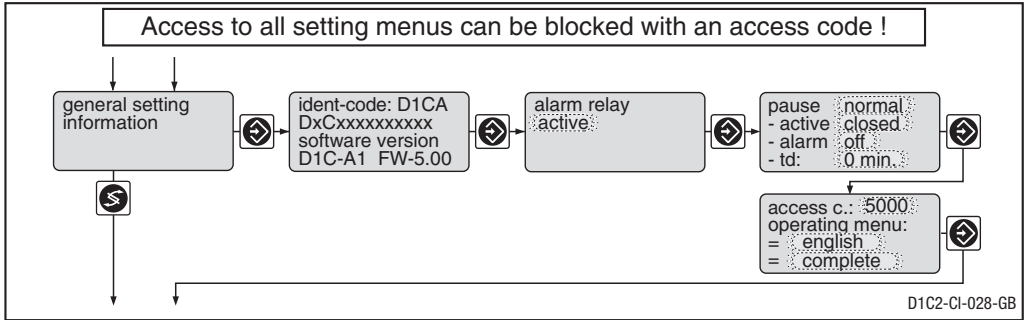

	Initial value	Possible values			Remarks
		Increment	Lower value	Upper value	
Alarm relay	active	active not active			Alarm relay can be triggered by pause contact.
Control input pause	closed	closed open			
Pause	Pause	Pause/Hold* Pause			
Control input pause	closed	closed open			
Pause with alarm	off	off on			
td	0 min	1 min	0 min	60 min	
Access code	5000	1	1	9999	
Language	as per identity code	as per identity code			
Operating menu	complete	reduced complete			

Complete Operating Menu / Description

Pause Normal

If the pause-switch is off, the DULCOMETER® D1C sets the operating outputs to “0” for as long as the pause-switch is off or for a set time-delay t_d (if t_d is set to > 0 min). Whilst the pause-switch is off, the D1C establishes the P-proportion in the background.

With PID-control (Identity code characteristics “control characteristic” = 2): the I-proportion is stored when the pause is switched off (I-proportion then usually only present if $T_n > 0$ has been selected in the “Control setting?” setting menu).

Exception: the standard signal outputs mA for the measured value or correction value are not affected by the pause.

After pause is activated the operating outputs remain at “0” for the length of the time-delay t_d . The time-delay t_d must be set up in such a way that, in this time e.g. sample water (process-specific current concentration) flows to the sensor.

With PID-control (Identity code characteristics “control characteristic” = 2): The control variable output resulting from the pause and the expiry of the time-delay t_d is reconciled jointly with the current P-component and (if T_n is set > 0) with the stored I-component.

Pause Hold

If the pause-switch is off, the DULCOMETER® D1C freezes the operating output at the most recent value for as long as the pause-switch is off or for a set time-delay t_d (if t_d is set to > 0 min). Whilst the pause-switch is off, the D1C establishes the P-proportion in the background.

With PID-control (Identity code characteristics “control characteristic” = 2):

Even the mA standard signal outputs for measured value or correction value are frozen.

After pause is activated the operating outputs remain frozen for the length of the time delay t_d . The time delay t_d must be set up in such a way that, in this time e.g. sample water (process-specific current concentration) flows to the sensor.

With PID-control (Identity code characteristics “control characteristic” = 2): The control variable output resulting from the pause and the expiry of the time-delay t_d is reconciled jointly with the current P-proportion and (if T_n is set > 0) with the newly established I-proportion.

Access Code

Access to the setting menu can be prevented by setting up an access code. The DULCOMETER® D1C controller is supplied with the access code 5000 which permits free access to the setting menu. The calibration menu remains freely accessible even when access to the setting menu is blocked by the code.

9 Fault / Remarks / Troubleshooting

Fault	Fault text	Symbol	Effect on metering	Effect on control	Alarm with ack- nowledgement	Remarks	Remedy
Measured value Checkout time exceeded	Check CI probe	€	Basic load	Stop	Yes	Function detachable	Check function of sensor, exceed checkout time
Signal exceeded/drops below value	Check CI input	€	Basic load	Stop	Yes	Signal <3.0 ±0.2 mA or >23 ±0.2 mA	Check sensor, transducer and cable connection
Calibration sensor with error	CI calib. defective	€	Basic load	Stop	No	Metering continues in case of error with unstable measured values	Check sensor, replace if necessary, recalibrate if necessary
Correction variable Signal exceeded/drops below value	Check feed forward input	€	Basic load	Stop	Yes	Signal <3 or >23 mA Value last valid is used	Check sensor, transducer and cable connection
Calibration pH with error	pH calibration faulty	€	Basic load	Stop	Yes		
Limit CLE	pH limit 1/2	€	Basic load	Stop	Yes	pH <5 >8.5	
Limit GSE/CTE	pH limit 1/2	€	Basic load	Stop	Yes	pH <5 >9.5	
Feed forward control Signal exceeded/drops below value	Check feed forward input	€		Stop	Yes	Signal <3.0 ±0.2 mA or >23 ±0.2 mA Value last valid is used	Check sensor, transducer and cable connection Value last valid is used
Signal exceeded, multiplicative		€		Stop			
Limit transgression after checkout time limits Control "on" Control "off"	CI limit 1 CI limit 2	€	Stop or Basic load	Stop	Yes Yes	Function detachable	Determine cause, reset values if necessary
Servomotor Position not reached	Servomotor defective	€			Yes	Servomotor closes	Check servomotor
Electronics error	System error	€ O	Stop	Stop	Yes	Electronic data faulty	Call in service

Fault / Remarks / Troubleshooting

Operation	Note text	Symbol	Effect		Alarm with acknowledgement	Remarks	Remedy
			on metering	on control			
Pause contact	Pause	EO	Stop	Stop	No/Yes*	No further fault check	-
	Pause/Hold	E	Unchanged	**	No	-	-
Stop button	Stop	EO	Stop	Stop	No	Relay drops out	-
During calibration	Probe slope too low	Slope CI low	Basic load	Stop	No	No error processing of measured variable	-
	Probe zero point too high	Slope CI high	Basic load	Stop	No	> 25 % > sensor slope > 200 % of norm slope	Check sensor, replace if necessary
	Zero point too low	Zero point low	Basic load	Stop	No	Zero point <3 mA Zero point >5 mA	Recalibrate in sample water without chlorine
Zero point too high	Zero point high	E	Basic load	Stop	No	25 % > sensor slope > 200 % of norm slope	Recalibrate
DPD-value <2 % measuring range	DPD > x.xx ppm				No		Recalibrate
Buffer distance too small	Buffer distance too small ! Δ buffer >2 pH !						Recalibrate
Probe zero point too low	pH zero point low	E	Basic load	Stop	No		Check sensor, replace if necessary
Probe zero point too high	pH zero point high						
Probe slope too low	pH slope low						
Probe slope too high	pH slope high						
Probe signal too unstable	Measured value unstable						
During sensor motor setting	Position feedback wrong	Direction check					
	Upper position <40 % max. value	Final value small					
	Lower position >30 % range	Final value big					

* depending on whether "Alarm on" or "Alarm off" set in "General settings"

** Function PI stable

Without correct adjustment the last valid values are still used

Check connection of relay, potentiometer
Adjust the operation region of the sensor motor correctly

